

## FEATURES & BENEFITS

### DESIGN

Angled drip tray to prevent water build up or freezing. Two piece unit with removable upper portion to allow for easy cleaning.

### CONSTRUCTION

Type 304 stainless steel for durability, aesthetic integration, and vandal resistance geometry.

### RETROFITABLE

Can be retrofitted over new or existing Haws 1109/1119 drinking fountains, along with similar competitors products.

### MOUNTING

Various mounting options allow for easy installation with pre-drilled holes.

### SAFETY

Captures and diverts water directly into drinking fountain bowl to prevent splashing or slipping hazards.



## OPTIONS

For more information, visit [www.hawsco.com](http://www.hawsco.com) or call (888) 640-4297.

## SPECIFICATIONS

The Haws 6469 drip tray is used as a retrofit accessory for the Haws 1920 bottle filler when mounting it over the Haws 1109 style of drinking fountains. Easy mounting instructions allow this tray to quickly convert the 1109 series to a bottle filling station. Made of 304 stainless steel, the upper portion can be easily removed, allowing the unit to be cleaned.

## APPLICATIONS

Model 6469 is designed to retrofit over Haws 1109/1119 drinking fountains that are already installed in the field to convert to a bottle filling station with the addition of the the 1920 bottle filler, or for new installations in public or private indoor/outdoor settings where drinking fountain and bottle filling stations are desired.

**6469 STRAINER DRIP TRAY INSTALLATION**

- 1 THE 6469 STRAINER DRIP TRAY ALLOWS THE INSTALLATION OF THE 1920 SERIES BOTTLE FILLER OVER HAWS 1109/1119 SERIES MODEL DRINKING FOUNTAINS. CENTER THE LOWER DRAIN PAN ALONG THE CENTERLINE OF THE FOUNTAIN.
- 2 EXTEND THE FRONT EDGE OF THE LOWER DRAIN PAN OVER THE EDGE OF THE FOUNTAIN BOWL BY APPROXIMATELY 1/4" (6mm). IT IS RECOMMENDED TO TEMPORARILY TAPE THE DRAIN PAN IN PLACE. INSTALL THE TOP COVER, AND ACTIVATE THE BOTTLE FILLER TO VERIFY THE WATER STREAM IS ALIGNED TO THE INLET HOLE. VERIFY THE LIP OF THE TOP COVER HANGS OVER THE EDGE OF THE FOUNTAIN BOWL.
- 3 MARK THE DRAIN PAN HOLE LOCATIONS ON THE FOUNTAIN. THE DRAIN PAN CAN NOW BE PERMANENTLY INSTALLED USING AN APPROPRIATE FASTENING METHOD (FASTENERS NOT SUPPLIED). FASTENING OPTIONS INCLUDE THRU BOLTS, RIVETS, TACK WELDS, AND DOUBLE-SIDED FOAM TAPE. INSTALL THE TOP COVER AND SECURE TO THE DRAIN PAN WITH THE SUPPLIED 4-40 FLAT HEAD SCREWS (QTY. 2).

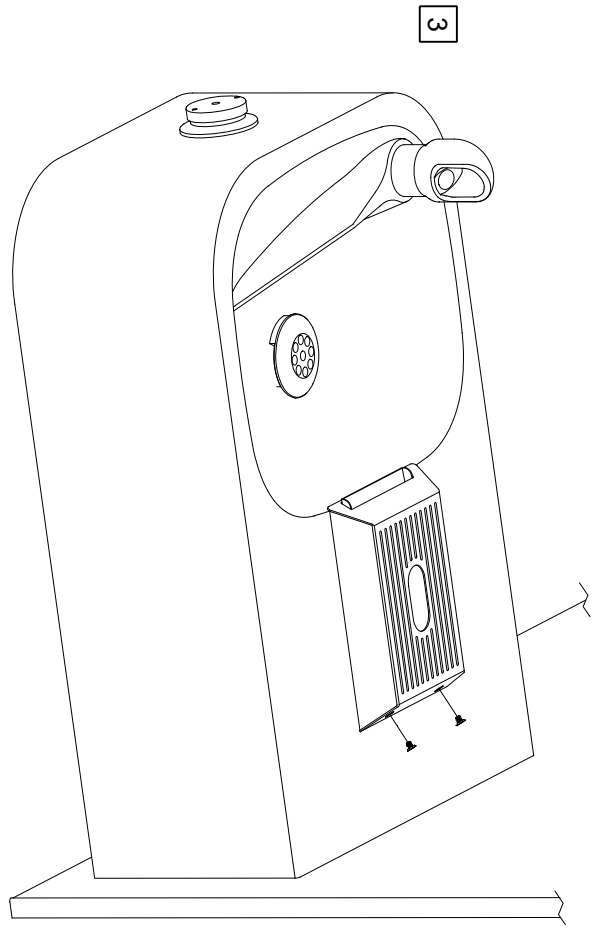
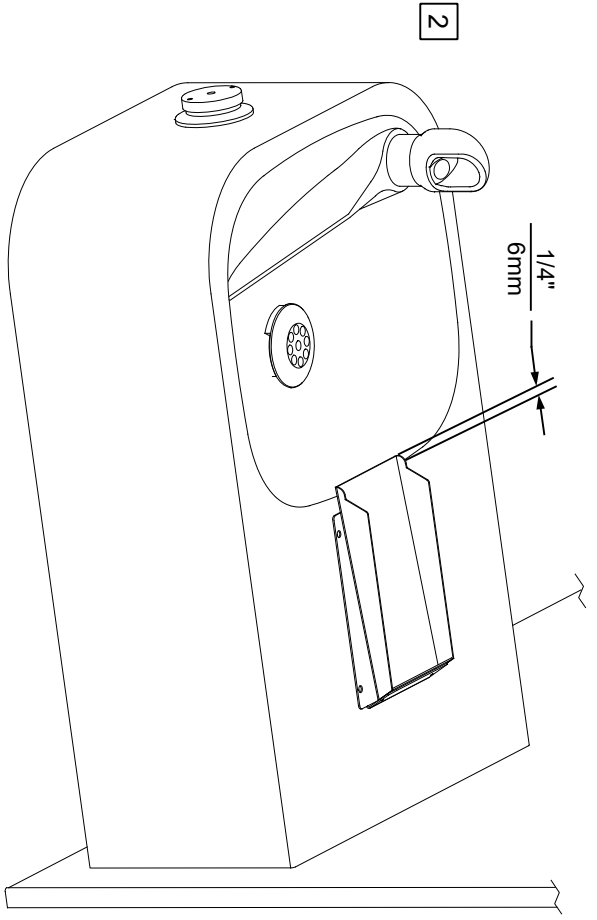
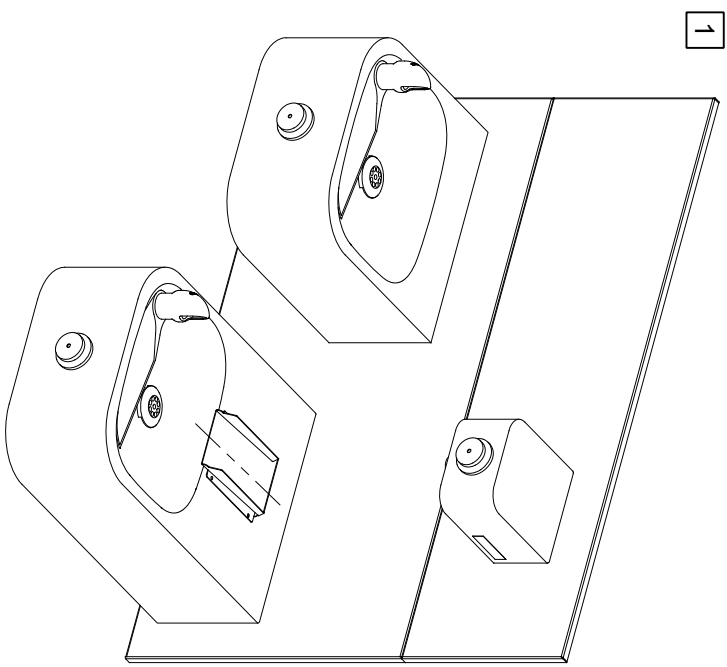

<b>HAWS</b>		1455 KLEPPE LANE	
SPARKS, NEVADA 89431		(775) 359-4712 FAX (775) 359-7424	
E-MAIL: HAWS@HAWS.CO.COM		WEBSITE: WWW.HAWS.CO.COM	
ECON NO. REVISED PER BY:	MODEL(S)	PART NUMBER	REVISION
5150 FV	6469	0510000657.D	2
DATE: 01/10/17	DATE: 07/08/22	SCALE: 1:4	DRAWING TYPE: INSTALLATION
APPROVED: FV	SCALE: 1:4	DRAWING TYPE: INSTALLATION	SIZE: A
DRAWING: MJ JS		SHEET 1 OF 1	