

FEATURES & BENEFITS

SENSOR OPERATED

Electric sensor allows for touch-free hygienic operation, eliminating the need for manual activation.

QUALITY CONTROL

The Haws bottle filling station is pre-built and fully water and pressure tested to ensure no leaks and proper function for reduced installation time and added peace of mind.

SERVICING & SECURITY

Durable ABS plastic front panel allows simple access to internal components. 30-second time-out prevents unwanted use. Hidden lock and hinges discourage vandals.

ADVANCED FILTRATION

2,500-gallon (9464 L) capacity, electronic lifecycle control filter cartridge will shut off water flow when capacity is reached to ensure fresh, filtered water with every activation. Filter replacement indicator light will flash yellow when filter life is at 10% and will flash red when replacement is necessary. Preparing to replace filter is important when the filter light flashes yellow.

EXTENDED WARRANTY

Superior engineering incorporated into this product carries an extended 3 year warranty.

OPTIONS

- Remote Drinking Fountain Water Chiller: Model HCR8, 8 GPH (30.3 L) remote chiller provides for instantaneous cooling to meet a continuous demand for chilled water.
- Replacement Filter: Model 6423 is the 2,500-gallon (9464 L) replacement filter with electronic lifecycle control for the Hydration By Haws™ Model 2000SMS.
- Surface-Mount Bottle Filler Drain Kit: Model 6470, optional drain assembly kit for 2000SMS surface-mount bottle filling stations.
- Custom Logo Panel: Standard Model 6475 comes with “Hydration By Haws™” logo. Customize the panel with your choice of logo, slogan, or graphic.

For more information, visit www.hawsc.com or call (888) 640-4297.



SPECIFICATIONS

Model 2000SMS Hydration By Haws™ water dispenser is a wall-mounted bottle or cup filling station constructed of durable ABS plastic and 16-gauge, Type 304 Stainless Steel with a satin finish. It features an electric sensor allowing for touch-free hygienic operation, laminar flow to prevent splashing, and a .5 gpm (1.3 L) flow rate for quick fill-up. 2,500 gallon (9464 L) carbon block filter reduces chlorine (taste and odor) and lead, and removes 99.99% of cysts. Hidden lock and hinges on ABS plastic front panel allows access to internal components. The mounting consists of heavy-gauge galvanized steel mounting bracket and hardware, and an adjustable, external electrical cord with maximum length of 6'. 110 volt, 60Hz, and .1 amp draw when in use. A removable water catch basin is provided; this may be converted to a hard-plumbed drain with a retrofit kit.

APPLICATIONS

The surface-mount Hydration By Haws™ bottle filling station is perfect for mounting on block or solid walls which cannot be cut into and where a recessed mount station is not an option. The surface-mount unit does not require a drain trap and has an integrated drain pan allowing it to be mounted in any location where there is a reasonable access to a water line. Specifically, this bottle filling station is ideal for office buildings, airports, schools, manufacturing facilities and municipalities. Model 2000SMS meets the Americans with Disabilities Act when mounted at the correct height, and cane bump bar is properly installed (see Operators Manual). Haws manufactures drinking fountains and electric water coolers to be lead-free by all known definitions including NSF/ANSI Standard 61, Section 9, NSF/ANSI Standards 42 & 53, NSF/ANSI 372, and CSA Standard B483.1. Product is compliant to California Health and Safety Code 116875 (AB 1953), California Proposition 65 and the Federal Safe Drinking Water Act. Model 2000SMS is certified to the standard for Water Treatment Appliances (UL979).





INSTALLATION GUIDE

1455 Kleppe Lane ♦ Sparks, NV 89431-6467 ♦ (888) 909-4297
♦ website: www.Hawesco.com

No. 0510000664 (3)

Model 2000SMS Bottle Filler with Lifecycle Control

NOTE: A Class A ground-fault circuit interrupter (GFCI) shall be installed in the branch-circuit supplying power to this unit.

CAUTION! Prior to making any electrical connections, verify with a voltmeter that power from the service panel is **off**.

SHOULD YOU EXPERIENCE DIFFICULTY WITH THE INSTALLATION OF THIS MODEL, OR REQUIRE REPLACEMENT PARTS, PLEASE CALL:

**TECHNICAL SUPPORT:
1-800-766-5612**

HOURS OF OPERATION: MON-THURS 7:00a.m. - 4:30p.m PT, FRI 7:00a.m.- 11:00a.m. PT

QUICK START REFERENCE

PARTS LIST: 1 Bottle Filler, 1 filter cartridge, 1 plastic drain basin, 1 hex key, 1 grommet.

RECOMMENDED TOOLS: Phillips screwdrivers, level.

REQUIRED PARTS (NOT SUPPLIED): 1/2" screwdriver stop, 3/8" tubing (to be used for water supply inlet), 6 1/8" x 3" zinc-plated steel toggle bolts, 6 zinc-plated steel 1/8" fender washers.

PRODUCT INSTALLATION: When installing this product, local, state or federal codes should be adhered to. This unit is certified for indoor use only.

SUPPLY LINE: Minimum recommended line size is 1/2" IPS with 30-90 PSI (2-6 ATM) flowing pressure; supply water is to be cold water supply. Intended for municipal water only.

PLUMBING CONNECTIONS: Inlet is 3/8" O.D. push-in type fitting. If a waste is desired, the Haws 6470 retrofit 1-1/4" O.D. waste kit may be used.

ELECTRICAL CONNECTIONS: 115VAC, 60HZ, approx. 0.14A. Unit is equipped with a standard 115VAC plug.

RATED SERVICE FLOW: 0.5 GPM (2725L/day)

OPERATING TEMPERATURE: 35–100°F (1.7–37.8°C)

OPERATING PRESSURE: 30-90 PSI

FILTER CAPACITY: 2500 gallons (9460L) or 1 year

REPLACEMENT FILTER CARTRIDGE: Electronic Lifecycle Control Filter Model 6423

INSTALLATION PROCEDURE

WARNING: Make certain power is disconnected before installation to reduce risk of electrical shock.

WARNING: Filter is not intended to withstand operating pressures greater than 100 PSI (6.8 ATM). If inlet pressure is greater than this, filter must be protected with a pressure regulator.

NOTES:

1. This unit is certified for indoor use only.
2. For all plastic push-in type fitting connections, only connect NSF-61 copper or plastic tubing. Stainless steel or glass tubing is not recommended. The following assembly instructions must be followed to ensure a watertight connection:
 - a. Cut tubing square and clean.
 - b. Mark from end of tube the length of insertion (See table below).
 - c. Push tube into the fitting until it bottoms out.
 - d. To remove, depress collet and pull tubing out.

| Tube Sizes | O.D. Tolerance | Insertion Depth |
|------------|----------------|-----------------|
| 1/4" | ±.005" | 11/16" |
| 3/8" | ±.005" | 3/4" |
| 1/2" | ±.005" | 7/8" |

2. Use NSF-61 approved pipe joint sealant on all threaded water connections.
3. Do not use with water that is microbiologically unsafe or unknown quality without adequate disinfection before or after the system. Systems certified for cyst reduction may be used on disinfected waters that may contain filterable cysts.
4. Use the cardboard inserts from the box to support the unit while preparing for installation by placing unit face down on inserts.
5. There is an opening in the bottom of the unit to accommodate a plumbed waste. If a plumbed waste is desired, the Haws model 6470 retrofit kit may be used.

Step 1: To open the unit, slide the supplied hex key into the notch in the left-hand side of the hinged upper plastic panel and press the key firmly in that same direction. This will disengage the internal spring latch. Simultaneously pull open the hinged panel (see Step 1 Diagram). Take care not to damage the stainless steel panel or the spring latch in this process.

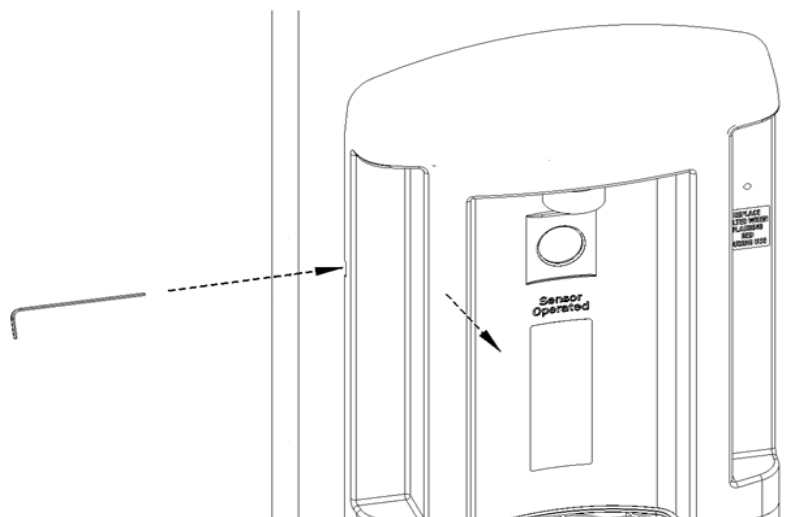

Step 1 Diagram

Step 2: Remove the 4 mounting screws on the outside of the bottle filler with a Phillips screwdriver (see Step 2 Diagram) and remove the mounting bracket from the bottle filler.

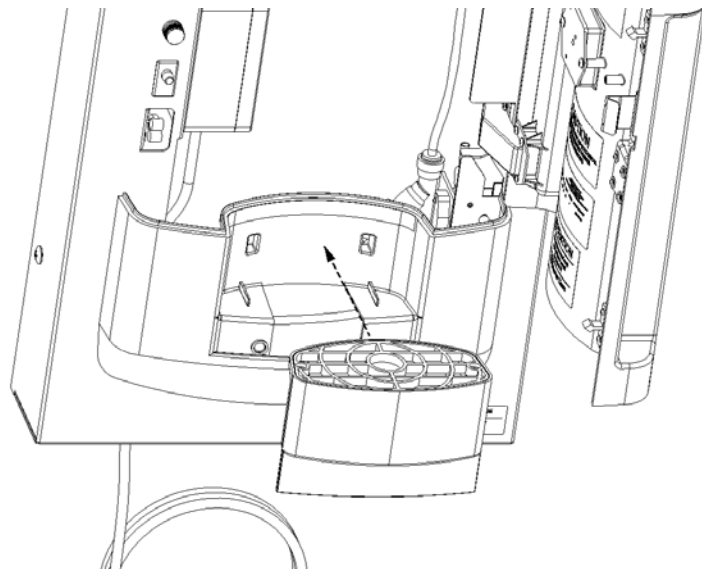

Step 3 Diagram

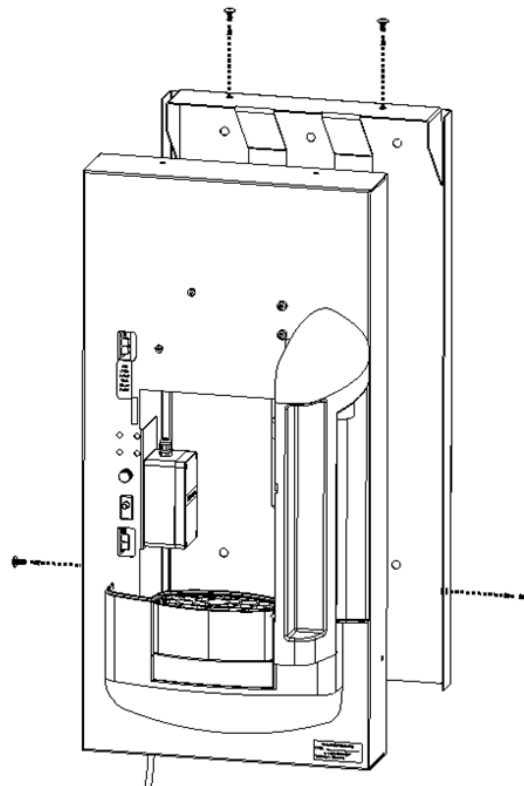

Step 2 Diagram

Step 3: Remove the drain basin, drain grate, and filter cartridge from the small box inside the main shipping carton. Install the drain basin with grate into the front of the unit (see Step 3 Diagram), pushing it straight in until the snap latches are fully engaged.

Step 4: Firmly screw the filter cartridge into the filter head (see Step 4 Diagram). NOTE: the bottle filler will work only if a filter cartridge is installed and its wiring is plugged in (see Step 7).

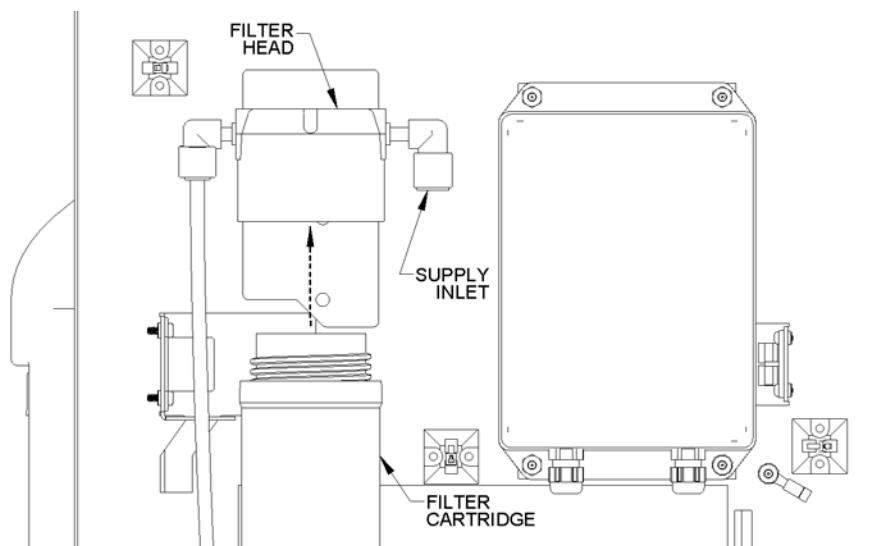

Step 4 Diagram (Back View)

Step 5: The bottle filler is supplied with a power cord. If desired, the power cord may be removed and the unit may be wired through one of the extra holes in the mounting bracket. Install a supply line through the bottom as shown in Steps 5 & 6 Diagram by removing the plug from the port and installing the supplied grommet – for use with 3/8" tubing. If desired, one of the extra ports in the mounting bracket may be used for the supply inlet instead. Connect the supply line with a screwdriver stop (not supplied). Double-check supply and electrical locations.
NOTE: When installing this unit, all pertinent local, state, or federal codes should be adhered to.

Step 6: Secure the detached mounting bracket to the wall; a number of mounting holes are provided to fasten the bracket direct to the wall (see Step 5 & 6 Diagram for mounting hole pattern or use the mounting bracket itself as a template). Note that the bottle filler weighs approximately 30 pounds. As such, attach the mounting bracket using six 1/8" x 3" zinc-plated steel toggle bolts (not supplied) in conjunction with six appropriately-sized zinc-plated steel 1/8" fender washers (not supplied). Use a level to verify horizontal and vertical frame mounting.

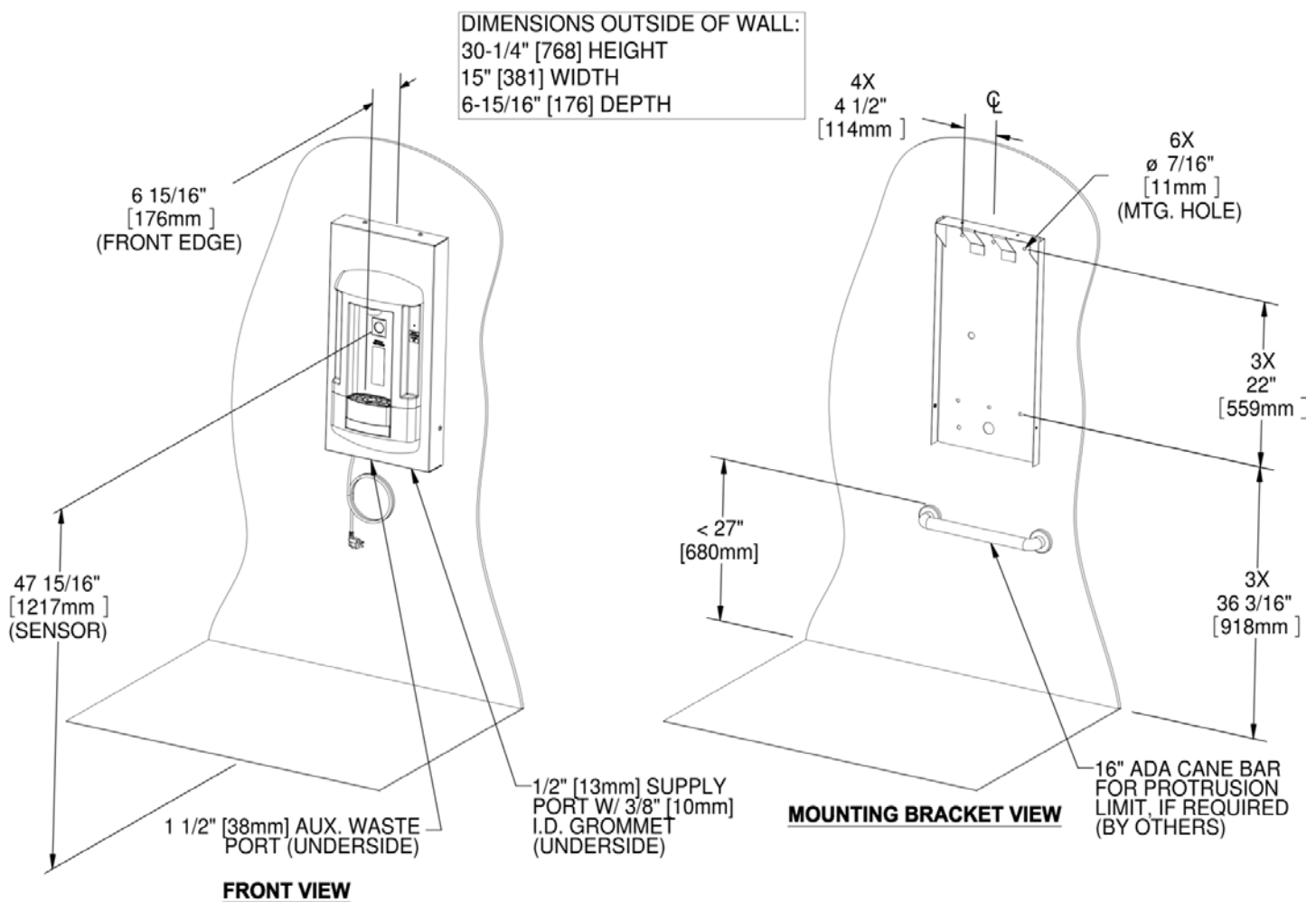

Steps 5 & 6 Diagram

Step 7: Place the bottle filler onto its mounting bracket and run 3/8" tubing (not supplied) between the screwdriver stop (installed in Step 5) and the bottle filler's supply inlet elbow in the filter head (it may help to temporarily remove the filter cartridge – see Step 7 Diagram). Connect the wiring coming off of the filter cartridge to the wiring coming out of the circuit board enclosure (see Step 7 Diagram).

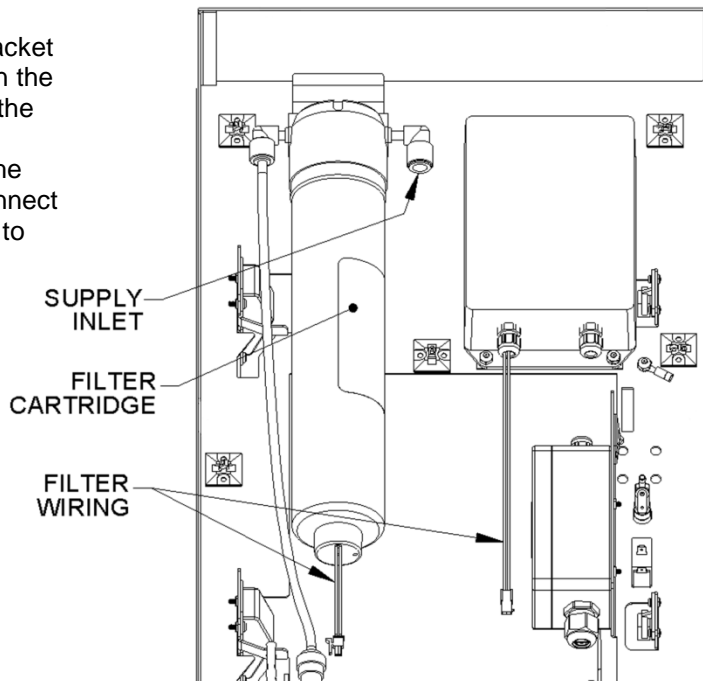

Step 7 Diagram (Back View)

Step 8: Replace the mounting screws removed in Step 2 (see Step 2 Diagram for details). Provide AC power to unit.

Step 9: Activate the bottle filler by placing a bottle or cup in front of the sensor (see Step 9 Diagram A). If water does not dispense, see the Troubleshooting Guide in the Owner's Manual. The pressure regulator may need to be adjusted to better complement the input pressure at the installation site (see Step 9 Diagram B). To do so, pull out the adjustment knob and rotate as needed (clockwise from the front of the unit decreases flow); push knob in when desired flow is achieved.
* Flow rate is factory set to the maximum flow rate for decreased water consumption.

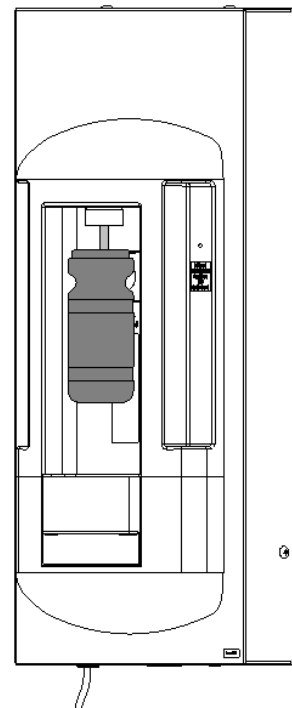

Step 9 Diagram A

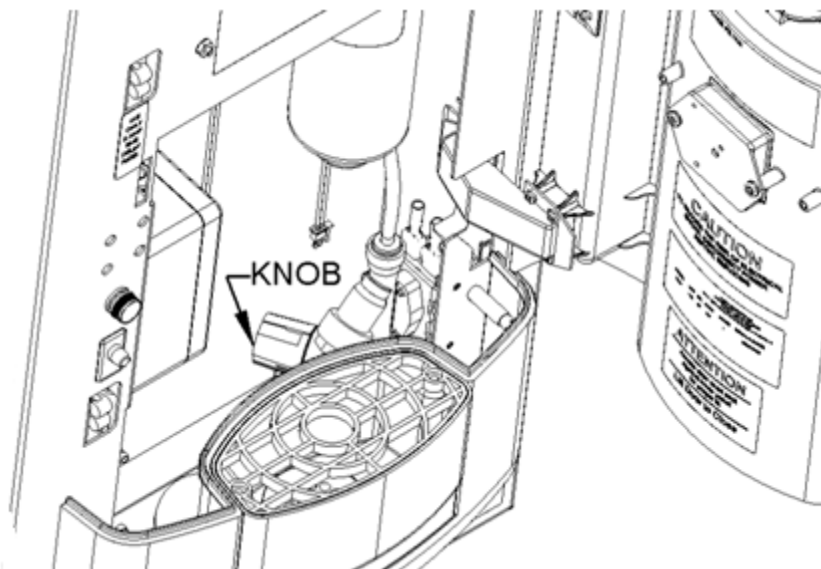

Step 9 Diagram B

Step 10: **Approximately five gallons** of water must be run through the system after the unit is installed in order to remove the loose carbon particles from the filter cartridge and any air bubbles from the system (both of these are normal occurrences after a filter change). Check the system for leaks. Place hex key in a secure location.

Step 11: Clean the front of the bottle filler to remove any grease or contaminants. Tape the cardboard template onto the front of the bottle filler, aligning the top and sides flush with the bottle filler panel (see Step 11 Diagram). Remove the adhesive backing from the logo plate and carefully place into the window of the alignment template. Press firmly to secure the logo plate. Remove and discard the cardboard template.

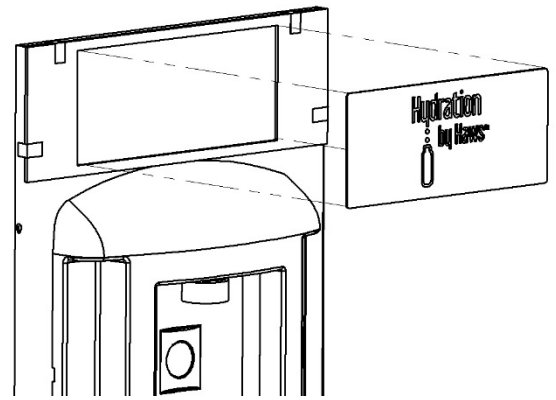

Step 11 Diagram