



# INSTALLATION GUIDE

1455 Kleppe Lane ♦ Sparks, NV 89431-6467 ♦ (888) 909-4297  
♦ website: [www.Hawesco.com](http://www.Hawesco.com)

No. 0510000663 (2)

## Model 2000S/2000SN Bottle Filler with Lifecycle Control

**NOTE:** A Class A ground-fault circuit interrupter (GFCI) shall be installed in the branch-circuit supplying power to this unit.

**CAUTION!** Prior to making any electrical connections, verify with a voltmeter that power from the service panel is **off**.

**SHOULD YOU EXPERIENCE DIFFICULTY WITH THE INSTALLATION OF THIS MODEL, OR REQUIRE REPLACEMENT PARTS, PLEASE CALL:**

**TECHNICAL SUPPORT:  
1-800-766-5612**

HOURS OF OPERATION: MON-THURS 7:00a.m. - 4:30p.m PT, FRI 7:00a.m.- 11:00a.m. PT

### QUICK START REFERENCE

**PARTS LIST:** 1 bottle filler, 1 filter cartridge, 1 plastic drain basin, 1 brass waste bend, 1 waste nut, 1 rubber waste washer, 1 hex key, 2 drain basin screws, 2 drain basin screw washers.

**RECOMMENDED TOOLS:** Phillips screwdrivers, level, slip joint pliers.

**REQUIRED PARTS (NOT SUPPLIED):** Qty. 6 – 10 #6 sheet metal or wood screws (depending on construction of wall studs), 1/2" screwdriver stop, 3/8" tubing (to be used for water supply inlet), 1-1/4" trap, qty. 3 wire connectors.

**PRODUCT INSTALLATION:** When installing this product, local, state or federal codes should be adhered to. This unit is certified for indoor use only.

**SUPPLY LINE:** Minimum recommended line size is 1/2" IPS with 30-90 PSI (2-6 ATM) flowing pressure; supply water is to be cold water supply. Intended for municipal water only.

**PLUMBING CONNECTIONS:** Inlet is 3/8" O.D. push-in type fitting. Waste bend is 1-1/4" O.D. pipe; an acceptable trap must be used after waste bend.

**ELECTRICAL CONNECTIONS:** 115VAC, 60HZ, approx. 0.14A. Unit wired directly to incoming line (stripped leads provided).

**RATED SERVICE FLOW:** 0.5 GPM (2725L/day)

**OPERATING TEMPERATURE:** 35–100°F (1.7–37.8°C)

**OPERATING PRESSURE:** 30-90 PSI

**FILTER CAPACITY:** 2500 gallons (9460L) or 1 year

**REPLACEMENT FILTER CARTRIDGE:** Electronic Lifecycle Control Filter Model 6423

# INSTALLATION PROCEDURE

**WARNING:** Make certain power is disconnected before installation to reduce risk of electrical shock.

**WARNING:** Filter is not intended to withstand operating pressures greater than 100 PSI (6.8 ATM). If inlet pressure is greater than this, filter must be protected with a pressure regulator.

**NOTES:**

1. This unit is certified for indoor use only.
2. For all plastic push-in type fitting connections, only connect NSF-61 copper or plastic tubing. Stainless steel or glass tubing is not recommended. The following assembly instructions must be followed to ensure a watertight connection:
  - a. Cut tubing square and clean.
  - b. Mark from end of tube the length of insertion (See table below).
  - c. Push tube into the fitting until it bottoms out.
  - d. To remove, depress collet and pull tubing out.

Tube Sizes	O.D. Tolerance	Insertion Depth
1/4"	±.005"	11/16"
3/8"	±.005"	3/4"
1/2"	±.005"	7/8"

3. Use NSF-61 approved pipe joint sealant on all threaded water connections.
4. Do not use with water that is microbiologically unsafe or unknown quality without adequate disinfection before or after the system. Systems certified for cyst reduction may be used on disinfected waters that may contain filterable cysts.
5. Use the cardboard inserts from the box to support the unit while preparing for installation by placing unit face down on inserts.

**Step 1:** To open the unit, slide the supplied hex key into the notch in the left-hand side of the hinged upper plastic panel and press the key firmly in that same direction. This will disengage the internal spring latch. Simultaneously pull open the hinged panel (see Step 1 Diagram). Take care not to damage the stainless steel panel or the spring latch in this process.

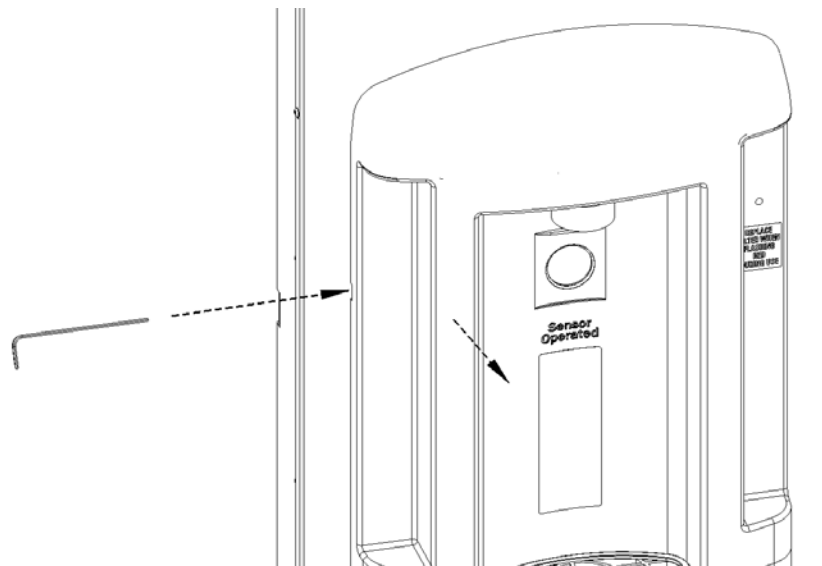

**Step 1 Diagram**

**Step 2:** Unscrew the 4 side-mounted panel screws on the outside of the bottle filler using the

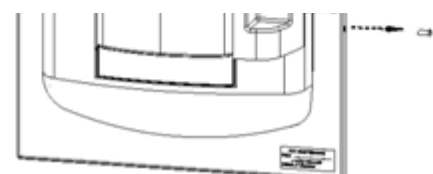

supplied hex key, and remove the mounting frame from the bottle filler (see Step 2 Diagram).

- Step 3:** Use the 2 washers and the 2 screws supplied to attach drain basin to unit as shown in Step 3 diagram (other components removed for clarity).  
Install waste bend with nut and rubber washer as shown (see Step 3 Diagram).

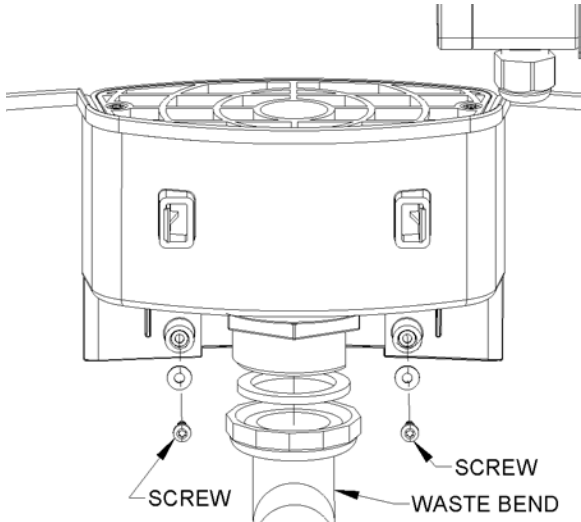

**Step 3 Diagram  
(Back View)**

**Step 2 Diagram**

- Step 4:** Firmly screw filter cartridge into filter head (see Step 4 Diagram). NOTE: Bottle filler will work only if a filter cartridge is installed and its wiring is plugged in (see Step 9).

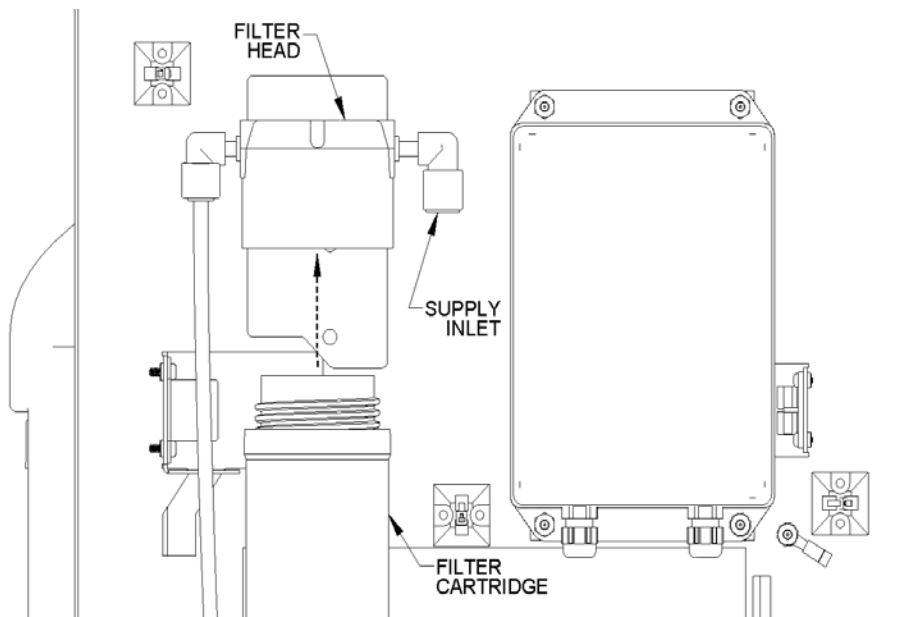

**Step 5:** Create a wall opening for the unit as shown in Step 5 Diagram – hold rough-in dimensions to within 1/8". The bottle filler is designed to fit between two normally spaced 2 X 4 studs (16" center-to-center).  
 Install waste line, supply line, and electrical lines in locations shown. The supply line should be brought up through the rectangular waste cutout in the bottom of the unit. Double-check waste, supply, and electrical line locations.  
 Install a 1/2" IPS supply screwdriver stop (not supplied) into the water supply line where it will be readily accessible.

NOTE: A suitable trap must be used in conjunction with the waste. This trap should be positioned in a location where it can be accessed and removed (it may be helpful to use a wall-mounted access panel).

NOTE: When installing this unit, all pertinent local, state, or federal codes should be adhered to.

**Bottle filler (rear cover removed) viewed from behind wall**

**ROUGH-IN DIMENSIONS:**  
 25-7/8" [657] HEIGHT  
 14-1/4" [362] WIDTH  
 FITS IN 2 X 4 WALL

**DIMENSIONS OUTSIDE OF WALL:**  
 30-1/4" [768] HEIGHT  
 15" [381] WIDTH  
 3-15/16" [100] DEPTH

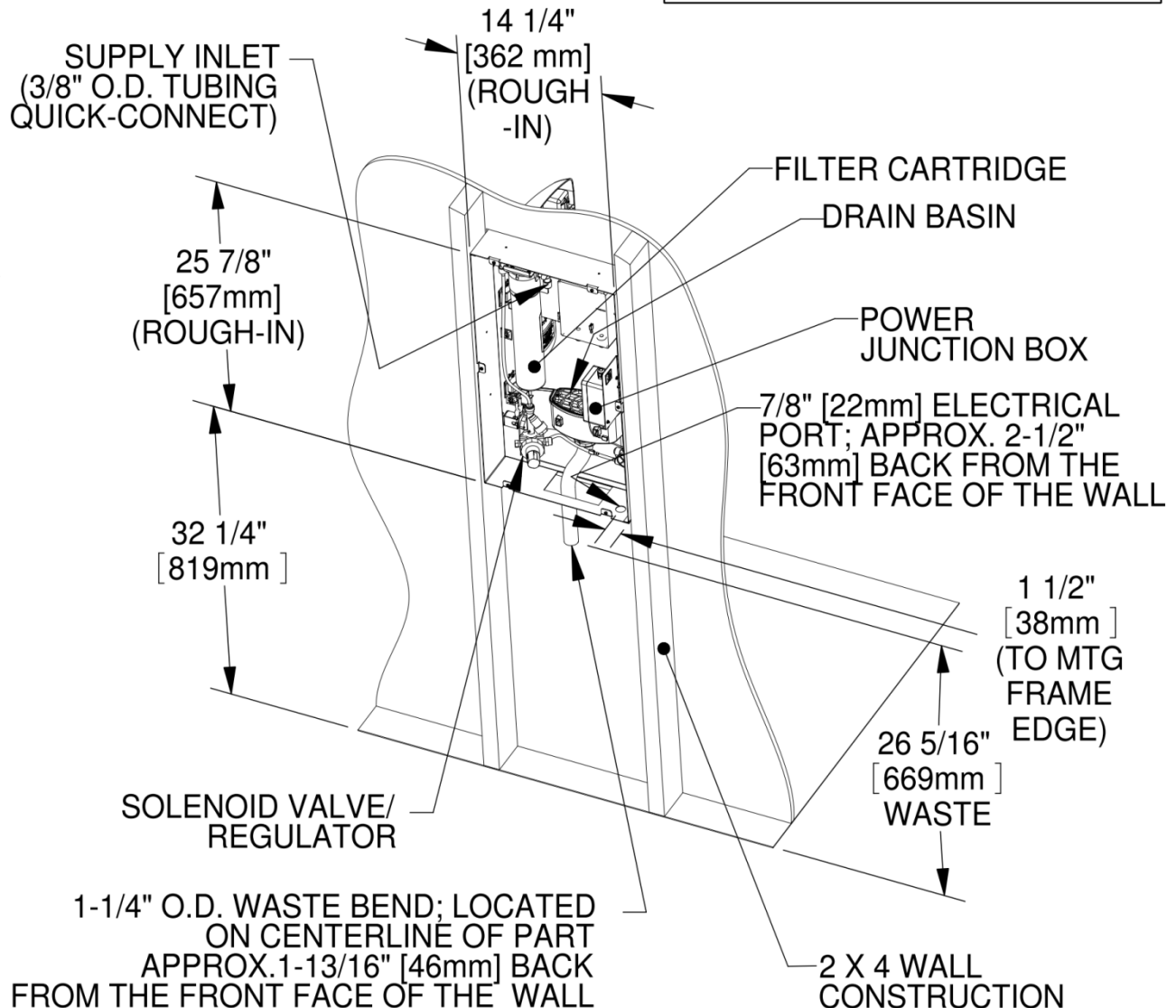

**Step 5 Diagram**

**Step 6:** Place the mounting frame into its opening such that it sits flush against the wall. Use some appropriate #6 screws (between 4 & 8 as required; not supplied) to secure the frame into the wall; notice that mounting holes are provided in the top, bottom, and sides of the mounting frame (see Step 6 Diagram).

Use a level to verify that the mounting frame is level horizontally and vertically; this will help to assure proper drainage and water flow that is properly aligned.

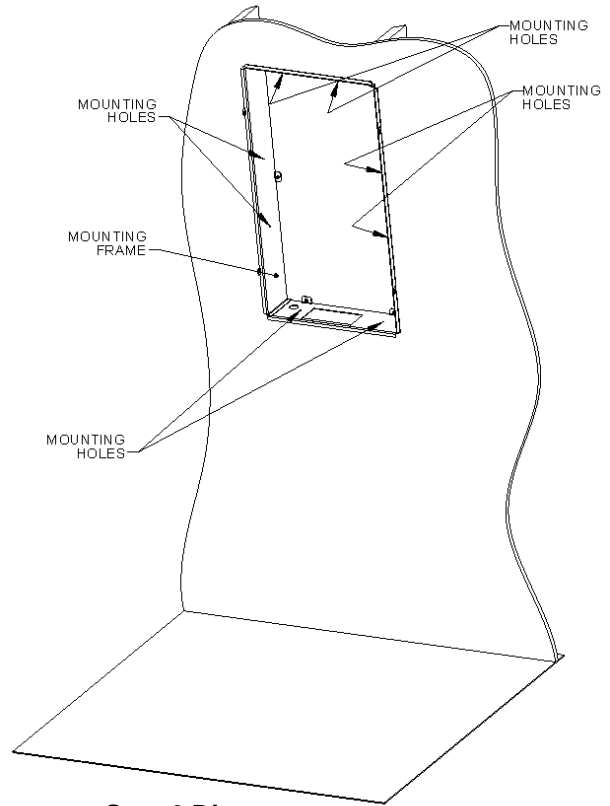

**Step 6 Diagram**

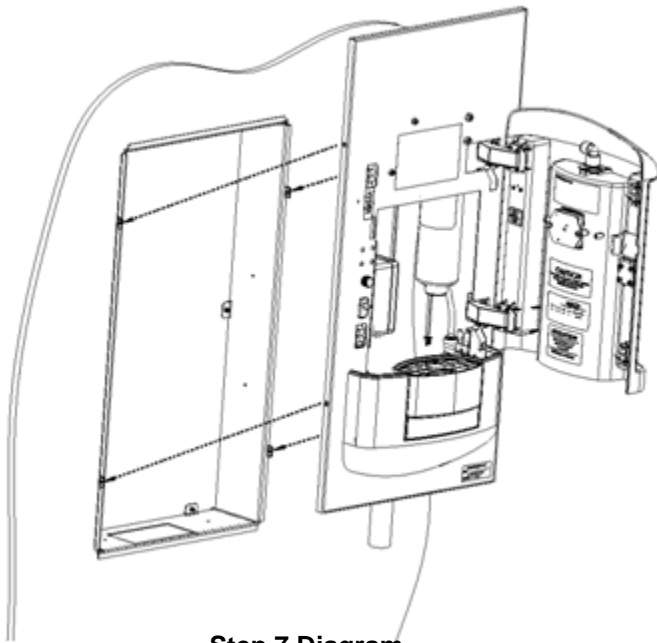

**Step 7 Diagram**

**Step 7 Diagram**

**Step 7:**

Place the bottle filler onto its mounting frame and make the connection between the bottle filler waste and the plumbed-in waste line. Secure the bottle filler to the mounting frame using the 4 screws removed in Step 2 (see Step 7 Diagram).

**Step 8:** Open the power junction box; run supply power wiring through the bottom cable grip. Connect supply power to lead (black), neutral (white), and ground (green) wires inside the box (stripped leads provided) (see Step 8 Diagram). Replace cover.

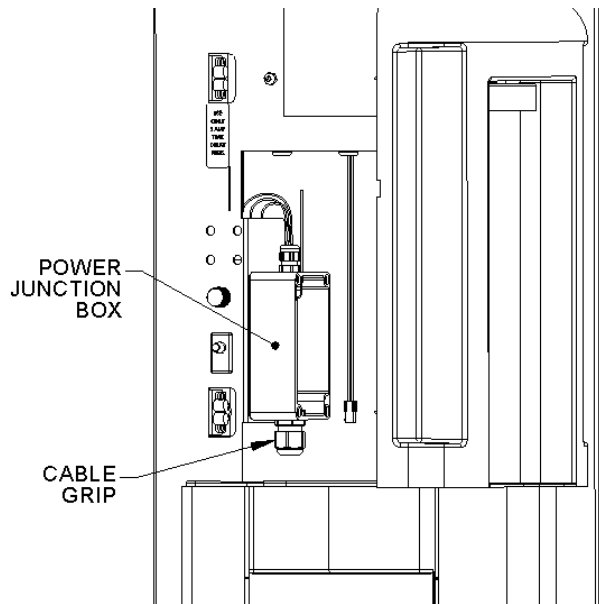

**Step 8 Diagram**

**Step 9:** Run 3/8" tubing (not supplied) between the screwdriver stop (installed in Step 5) and the bottle filler's supply inlet elbow in the filter head (it may help to temporarily remove the filter cartridge – see Step 9 Diagram). Connect the wiring coming off of the filter cartridge to the wiring coming out of the circuit board enclosure (see Step 9 Diagram).

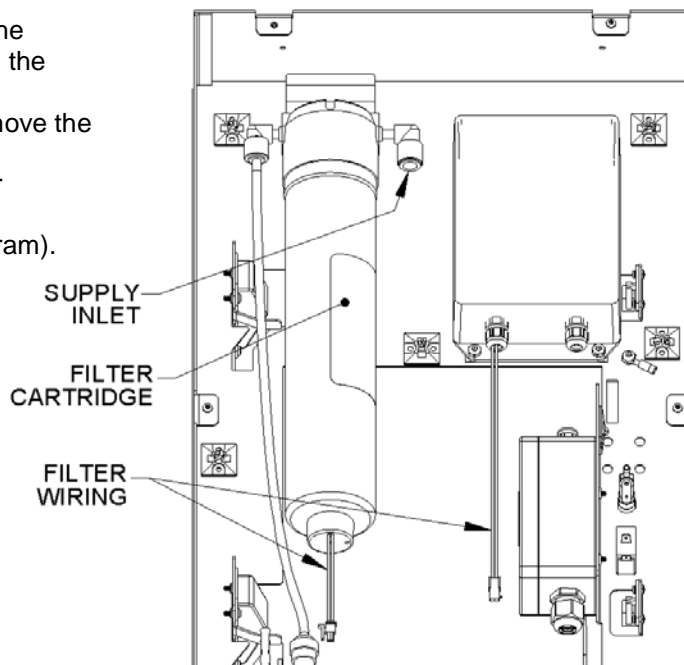

**Step 9 Diagram (Back View)**

**Step 10:** Open the screwdriver stop **wide open** and check for leaks. Close the hinged upper panel and provide power to the bottle filler.

**Step 11:** Activate the bottle filler by placing a bottle or cup in front of the sensor (see Step 11 Diagram A). If water does not dispense, see the Troubleshooting Guide in the Owner's Manual. The pressure regulator may need to be adjusted to better complement the input pressure at the installation site (see Step 11 Diagram B below). To do so, pull out the adjustment knob and rotate as needed (clockwise from the front of the unit decreases flow); push knob in when desired flow is achieved. \* Flow rate is factory set to the maximum flow rate for reduced water consumption.

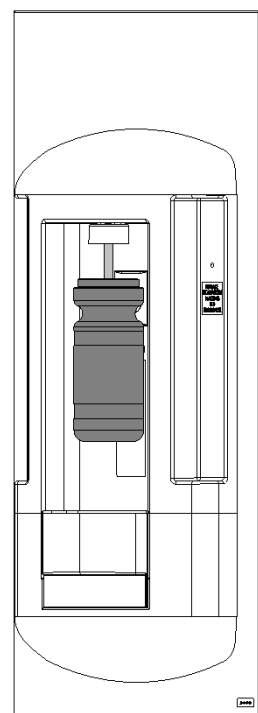

**Step 11 Diagram A**

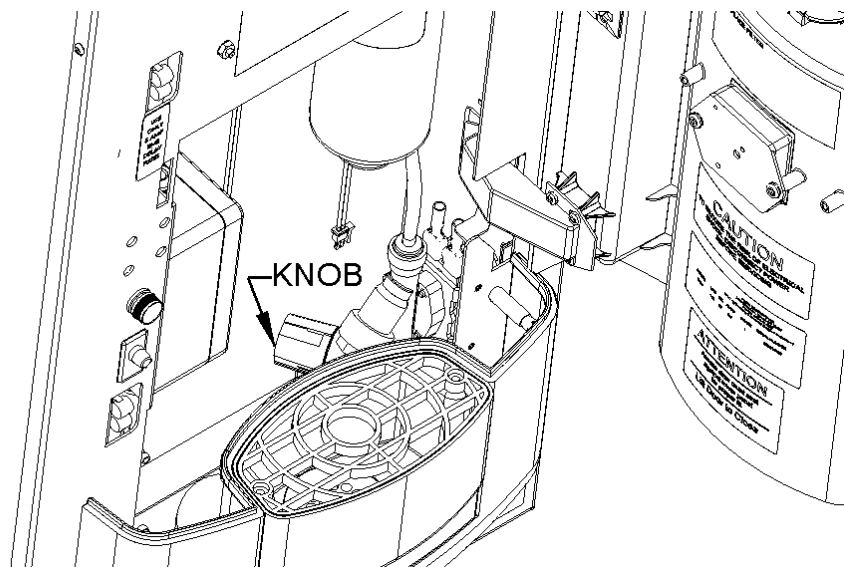

**Step 11 Diagram B**

**Step 12:** **Approximately five gallons** of water must be run through the system after the unit is installed in order to remove the loose carbon particles from the filter cartridge and any air bubbles from the system (both of these are normal occurrences after a filter change). Check the system for leaks. Place hex key in a secure location.