



# model 1920HPS

High Polished Bottle Filler

## FEATURES & BENEFITS

### PUSH BUTTON

With its patented stainless steel, push-button activated valve assembly which allows for front access stream adjustment as well as cartridge and strainer access, this bottle filler offers 100% lead free waterways. The valve works at an operating pressure range of 30 to 90 psi (2.1 to 6.2 bar).

### LAMINAR FLOW

Adjustable, splash-free, 1 gpm (3.78 L) laminar water flow.

### EFFICIENT & FLEXIBLE INSTALLATION

Unit is designed for retrofit or new construction applications. No drain required for mounting over existing drinking fountain.

### DURABLE BUILD

Good for indoor or outdoor applications (in non-freezing areas). Made with 100% Stainless Steel for vandal resistance.

### CONSTRUCTION

Unit is made of 14 gauge Type 304 stainless steel with a high polished finish that resists stains and corrosion, and has soft, rounded corners. Unit features vandal-resistant bottom plate.

### MOUNTING OPTIONS

Select from mounting plate and back panel models to complete installation. Unit can mount on various wall types.



## SPECIFICATIONS

Model 1920HPS wall mounted high-polished stainless steel bottle filler shall include 100% lead-free waterways, 1 gpm (3.78 L) laminar flow, push-button operated stainless steel valve with front-accessible cartridge and flow adjustment, and polished stainless steel construction. It can be used as a stand-alone station, or mounted above the Haws® 1001HPS and 1011HPS series drinking fountains.

## OPTIONS

- Mounting Plate: Model 6700 universal mounting plate for most wall mounted fountains. Priced Separately.
- Mounting Plate: Model 6700R mounting plate is used with the 1920 series bottle fillers for single or dual fountain retrofit installations.
- Back Panel: Model BP15HPS, polished stainless steel 15" back panel for Model 1920HPS.
- Back Panel: Model BP32HPS, polished stainless steel 32" back panel for model 1920HPS bottle filler.

For more information, visit [www.hawsc.com](http://www.hawsc.com) or call (888) 640-4297.

## APPLICATIONS

This type of wall mounted bottle filler may be placed in settings such as schools and other locations in and around office buildings with existing fountain installations where the temperature remains above freezing. Haws® manufactures drinking fountains and electric water coolers to be lead-free by all known definitions including NSF/ANSI 61, Section 9, NSF/ANSI 372, California Proposition 65, and the Federal Safe Drinking Water Act. Product is compliant to California Health and Safety Code 116875 (AB 1953-2006).

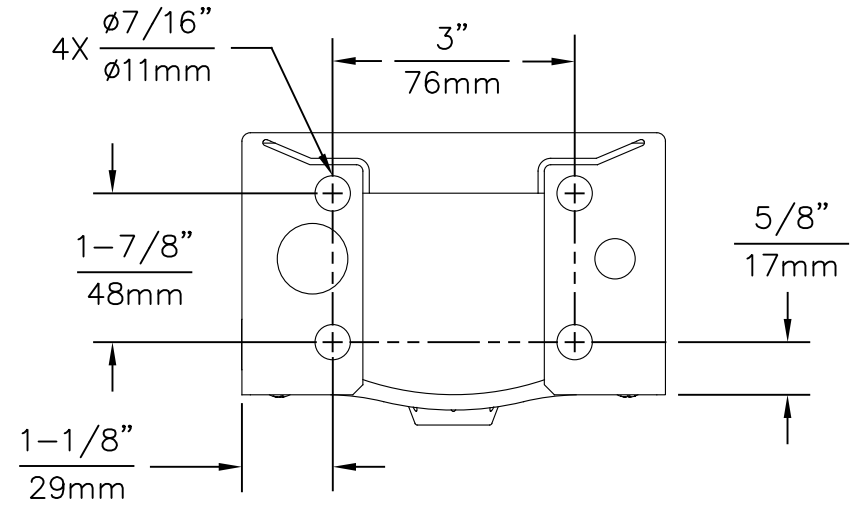
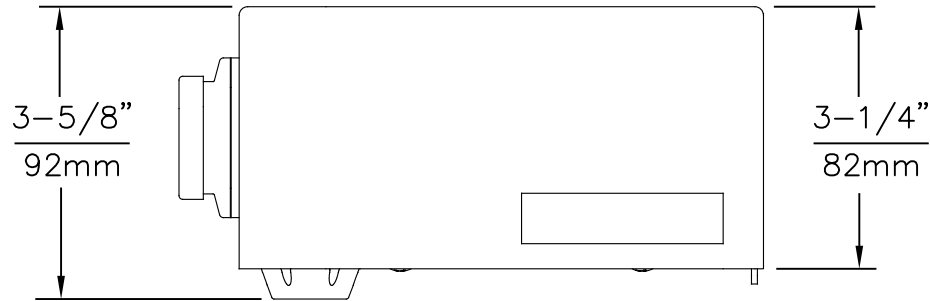

1920 MOUNTING HOLE LOCATIONS

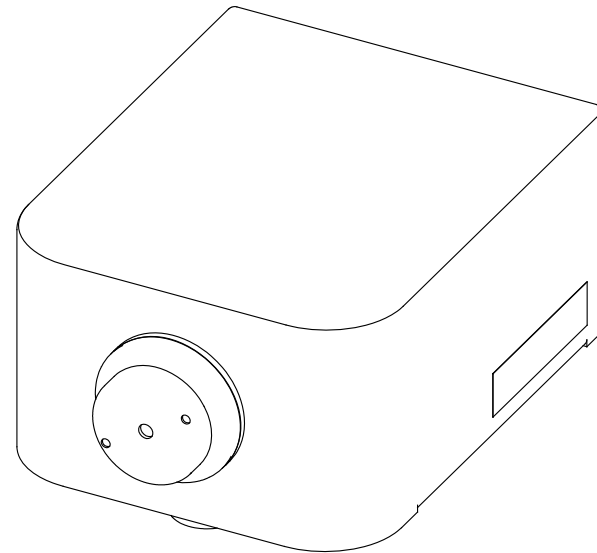
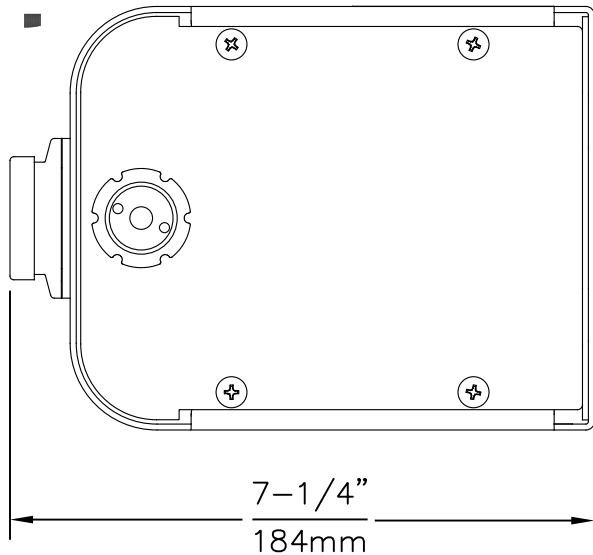

NOTES:

1. SEE SEPARATE INSTALLATION DRAWINGS FOR MOUNTING PLATES AND BACKPANELS
2. WHEN INSTALLING THIS UNIT, LOCAL, STATE OR FEDERAL CODES SHOULD BE ADHERED TO FOR INSTALLATION LOCATIONS, WASTE & SUPPLY REQUIREMENTS OTHER THAN SHOWN.

 <b>Haws</b> <sup>®</sup>		1455 KLEPPE LANE SPARKS, NEVADA 89431 (775) 359-4712 FAX (775) 359-7424 E-MAIL: HAWS@HAWS.CO.COM WEBSITE: WWW.HAWS.CO.COM	
		ECN NO. 5081 DRAWN: DS APPROVED: FV	REVISED PER: ECN: 5188 DATE: 05/25/16 DATE: 07/06/17
PART NUMBER 0510000490.D			REVISION 3
SCALE: N/A		DRAWING TYPE: INSTALLATION	SIZE: A SHEET 1 OF 5

6700.4L MOUNTING PLATE  
(BEHIND FINISH WALL)  
- OR -  
6700R RETROFIT PLATE  
(ON TOP OF FINISH WALL)

1920/1920HPS

BP32/BP32HPS  
(IF FOUNTAIN  
HIGH/LOW SIDES  
ARE REVERSED  
USE BP32R)

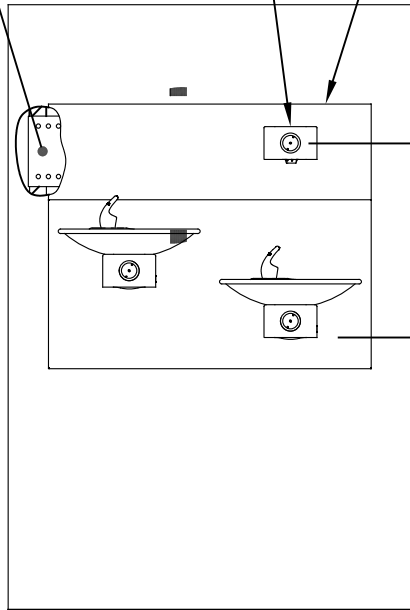

**INSTALLATION ABOVE HAWS 1011, 1011HPS,  
1011HPSMS, 1011MS, H1011.8, H1011.8HO, H1011.8HPS**

6700 MOUNTING PLATE  
(BEHIND FINISH WALL)  
- OR -  
6700R RETROFIT PLATE  
(ON TOP OF FINISH WALL)

1920/1920HPS

BP15/BP15HPS

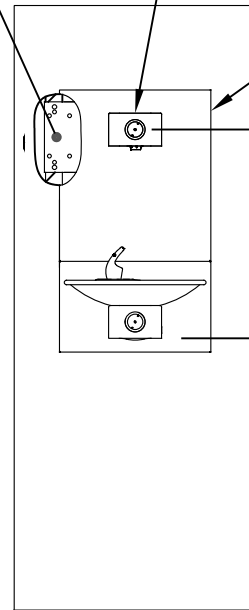

**INSTALLATION ABOVE HAWS 1001, 1001HPS,  
1001HPSMS, 1001MS, H1001.8, H1001.8HPS**

5-5/8"  
143mm

7-1/4"  
184mm

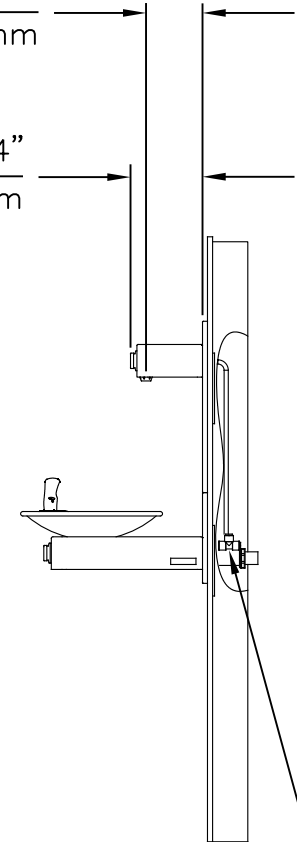

3/8" PUSH IN TEE  
(CONNECT TO  
FOUNTAIN SUPPLY)

\* IF YOUR FOUNTAIN IS THIS STYLE USE  
THESE DIMENSIONS

1. SEE SEPARATE INSTALLATION DRAWINGS FOR MOUNTING PLATES AND BACKPANELS
2. WHEN INSTALLING THIS UNIT, LOCAL, STATE OR FEDERAL CODES SHOULD BE ADHERED TO FOR INSTALLATION LOCATIONS, WASTE & SUPPLY REQUIREMENTS OTHER THAN SHOWN.

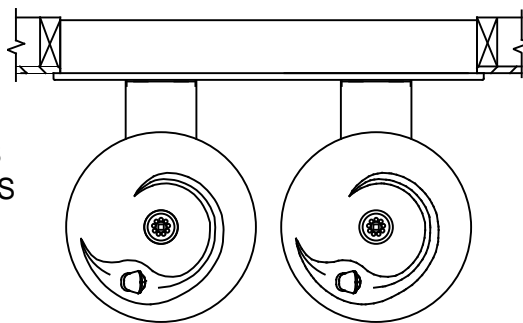

		1455 KLEPPE LANE SPARKS, NEVADA 89431 (775) 359-4712 FAX (775) 359-7424 E-MAIL: HAWS@HAWS.CO.COM WEBSITE: WWW.HAWS.CO.COM	
		ECN NO. 5081 DRAWN: MJ APPROVED: FV	REVISED PER: 5188 DATE: 01/30/17 DATE: 07/06/17
PART NUMBER 0510000490.D			REVISION 3
SCALE: N/A		DRAWING TYPE: INSTALLATION	SIZE: A SHEET 2 OF 5

6700.4L MOUNTING PLATE  
(BEHIND FINISH WALL)  
- OR -  
6700R RETROFIT PLATE  
(ON TOP OF FINISH WALL)

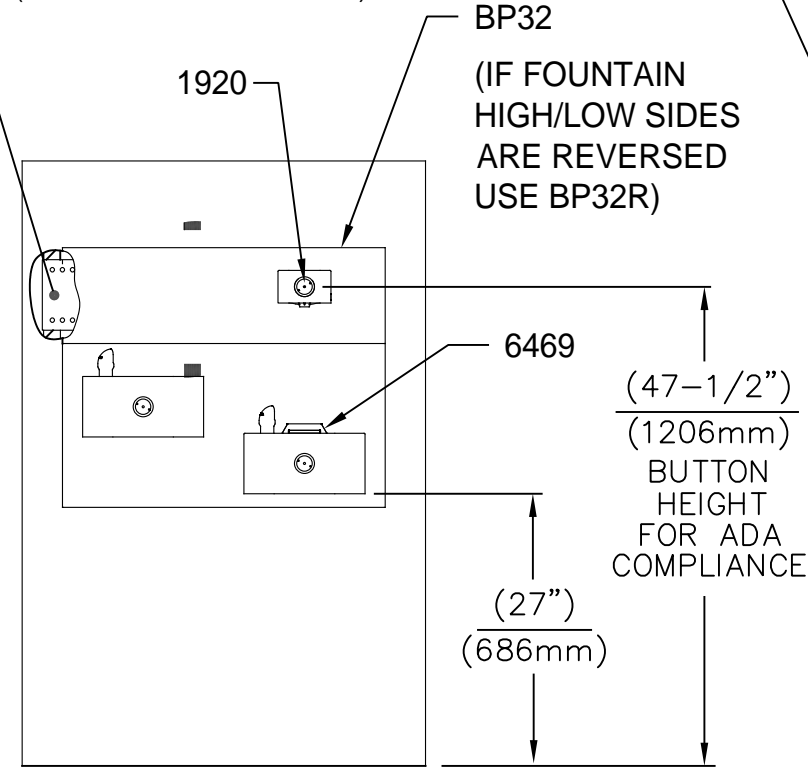

**INSTALLATION ABOVE HAWS 1119, 1119.14, H1119.8**

6700 MOUNTING PLATE  
(BEHIND FINISH WALL)  
- OR -  
6700R RETROFIT PLATE  
(ON TOP OF FINISH WALL)

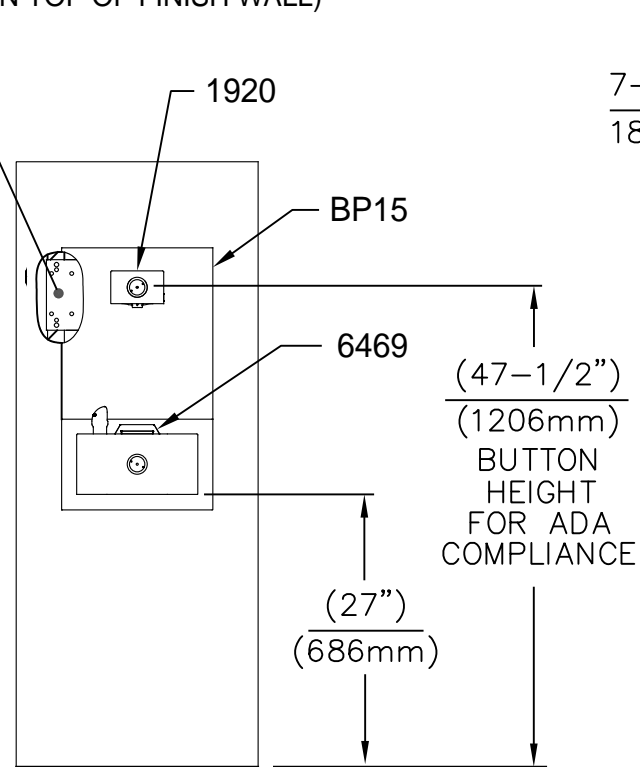

**INSTALLATION ABOVE HAWS 1109,  
1109.14, H1109.8**

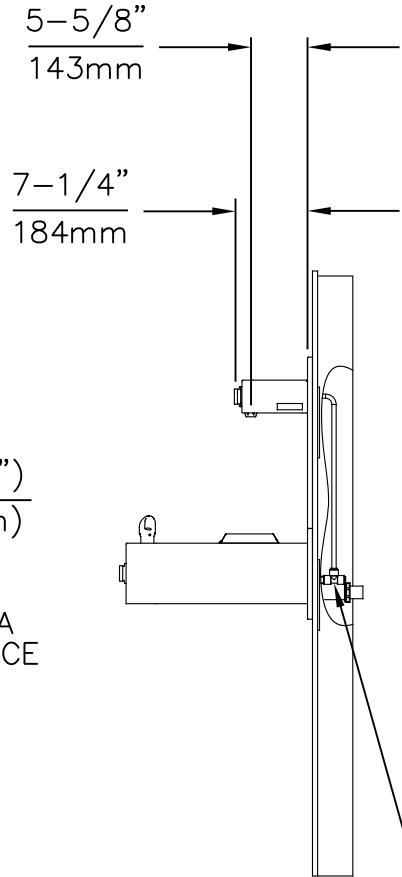

\* IF YOUR FOUNTAIN IS THIS STYLE USE THESE DIMENSIONS

1. SEE SEPARATE INSTALLATION DRAWINGS FOR MOUNTING PLATES, BACKPANELS & DRIP TRAY
2. WHEN INSTALLING THIS UNIT, LOCAL, STATE OR FEDERAL CODES SHOULD BE ADHERED TO FOR INSTALLATION LOCATIONS, WASTE & SUPPLY REQUIREMENTS OTHER THAN SHOWN.

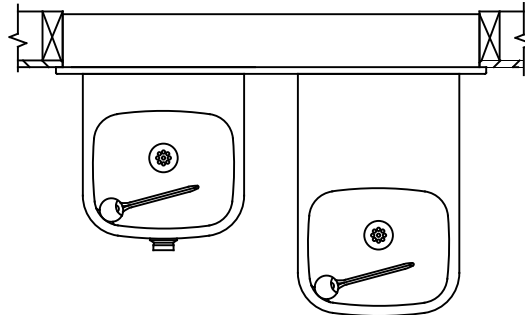

		1455 KLEPPE LANE SPARKS, NEVADA 89431 (775) 359-4712 FAX (775) 359-7424 E-MAIL: HAWS@HAWS.CO.COM WEBSITE: WWW.HAWS.CO.COM	
		ECN NO. 5081 DRAWN: MJ APPROVED: FV	REVISED PER: ECN: 5188 DATE: 01/30/17 DATE: 07/06/17
PART NUMBER 0510000490.D			REVISION 3
SCALE: N/A		DRAWING TYPE: INSTALLATION	SIZE: A SHEET 3 OF 5

6700.4L MOUNTING PLATE  
(BEHIND FINISH WALL)  
- OR -  
6700R RETROFIT PLATE  
(ON TOP OF FINISH WALL)

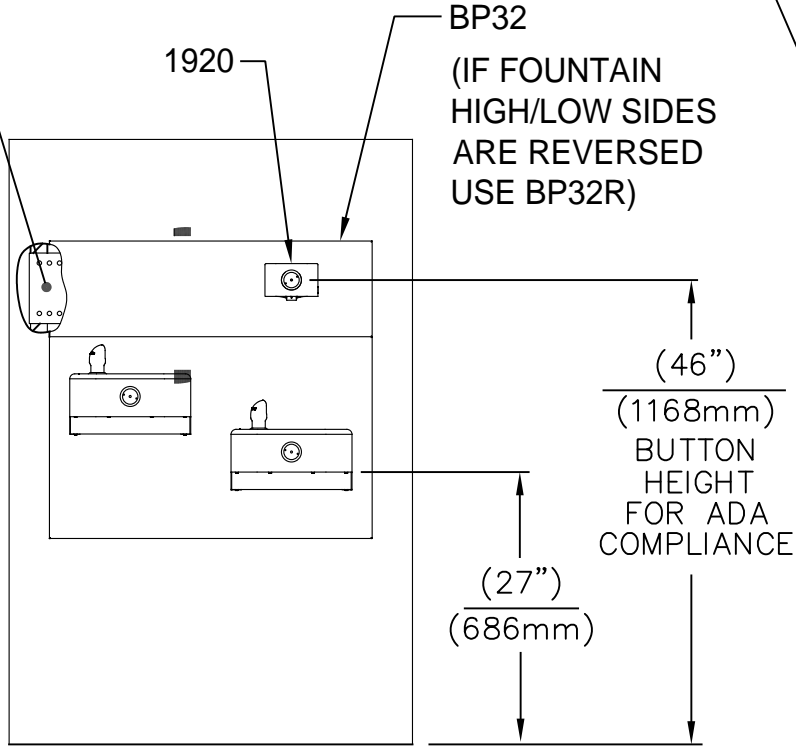

**INSTALLATION ABOVE HAWS 1117L, H1117.8**

6700 MOUNTING PLATE  
(BEHIND FINISH WALL)  
- OR -  
6700R RETROFIT PLATE  
(ON TOP OF FINISH WALL)

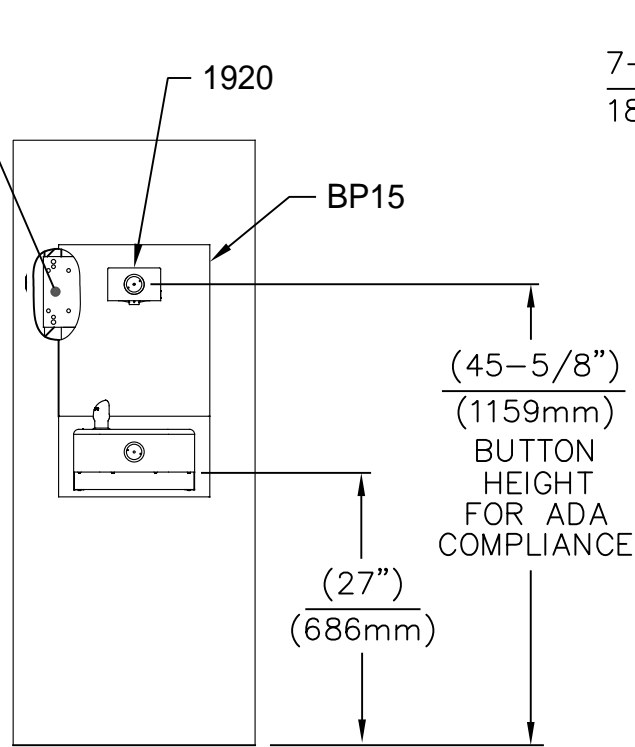

**INSTALLATION ABOVE HAWS 1107L, H1107.8**

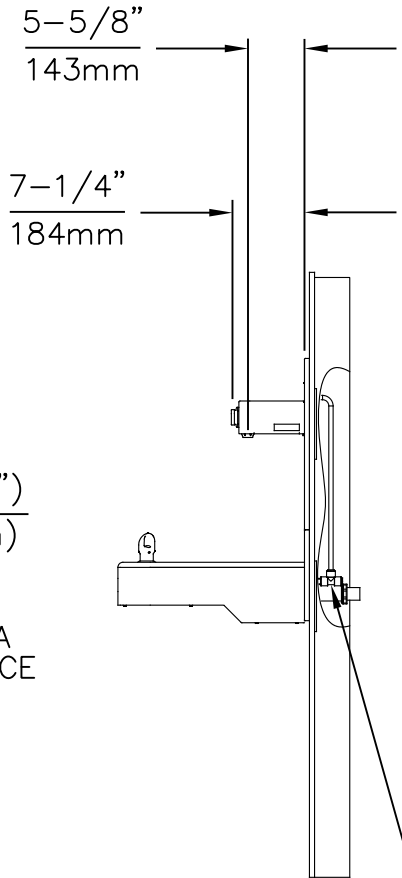

3/8" PUSH IN TEE  
(CONNECT TO  
FOUNTAIN SUPPLY)

\* IF YOUR FOUNTAIN IS THIS STYLE USE THESE DIMENSIONS

1. SEE SEPARATE INSTALLATION DRAWINGS FOR MOUNTING PLATES AND BACKPANELS
2. WHEN INSTALLING THIS UNIT, LOCAL, STATE OR FEDERAL CODES SHOULD BE ADHERED TO FOR INSTALLATION LOCATIONS, WASTE & SUPPLY REQUIREMENTS OTHER THAN SHOWN.

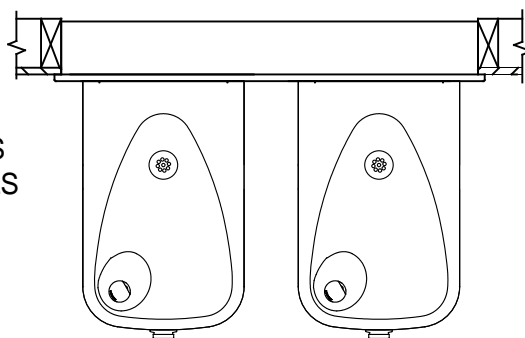

		1455 KLEPPE LANE SPARKS, NEVADA 89431 (775) 359-4712 FAX (775) 359-7424 E-MAIL: HAWS@HAWS.CO.COM WEBSITE: WWW.HAWS.CO.COM	
ECN NO. 5081	REVISED PER ECN: 5188	BY: JP	MODEL(S)
DRAWN: MJ	DATE: 01/30/17	CHK'D.: VWC	MODEL 1920/1920HPS/1920W
APPROVED: FV	DATE: 07/06/17	SCALE: N/A	DRAWING TYPE: INSTALLATION
		SIZE: A	SHEET 4 OF 5
		PART NUMBER 0510000490.D	REVISION 3

6700.4L MOUNTING PLATE  
(BEHIND FINISH WALL)  
- OR -  
6700R RETROFIT PLATE  
(ON TOP OF FINISH WALL)

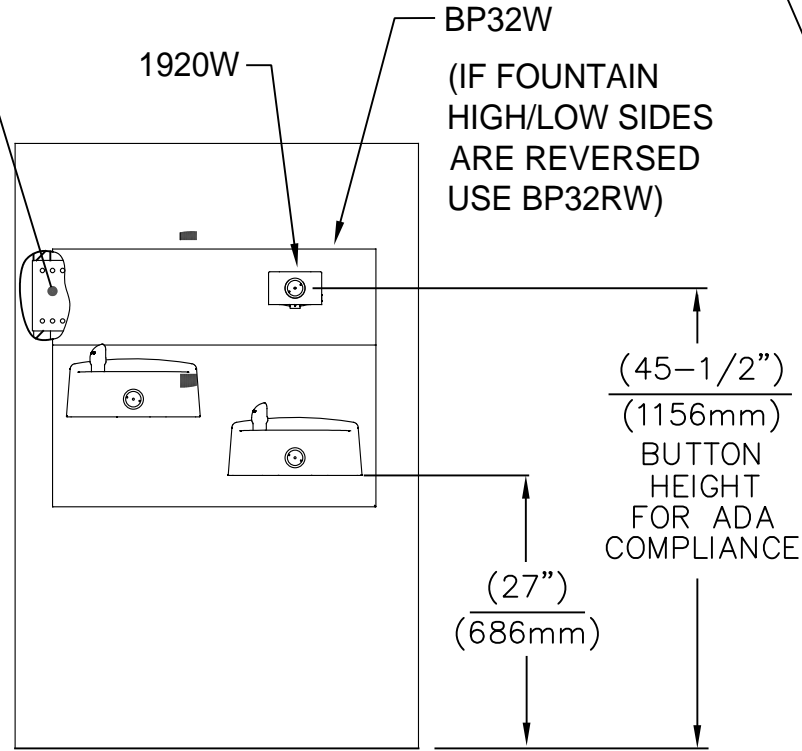

**INSTALLATION ABOVE HAWS 1501**

6700 MOUNTING PLATE  
(BEHIND FINISH WALL)  
- OR -  
BOLT 1920 ON TO  
EXISTING WALL

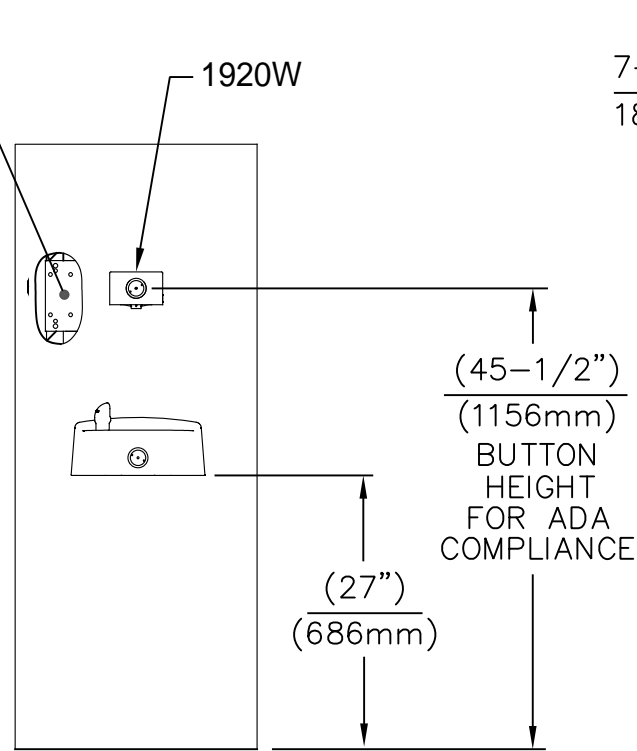

**INSTALLATION ABOVE HAWS 1311**

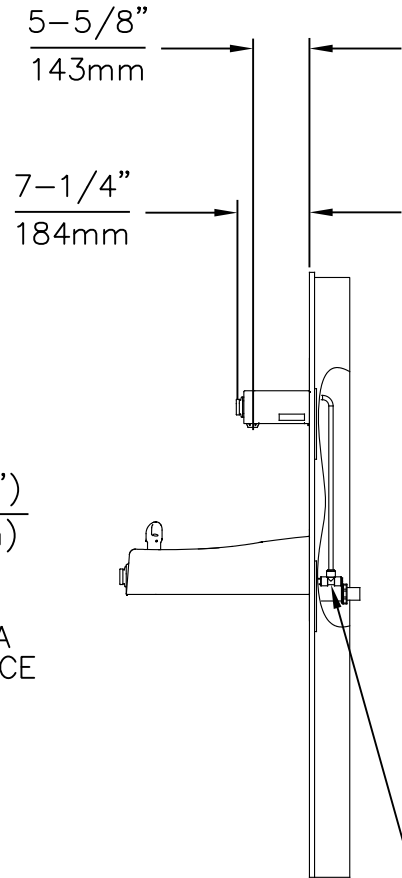

3/8" PUSH IN TEE  
(CONNECT TO  
FOUNTAIN SUPPLY)

\* IF YOUR FOUNTAIN IS THIS STYLE USE THESE DIMENSIONS

1. SEE SEPERATE INSTALLATION DRAWINGS FOR MOUNTING PLATES AND BACKPANELS
2. WHEN INSTALLING THIS UNIT, LOCAL, STATE OR FEDERAL CODES SHOULD BE ADHERED TO FOR INSTALLATION LOCATIONS, WASTE & SUPPLY REQUIREMENTS OTHER THAN SHOWN.

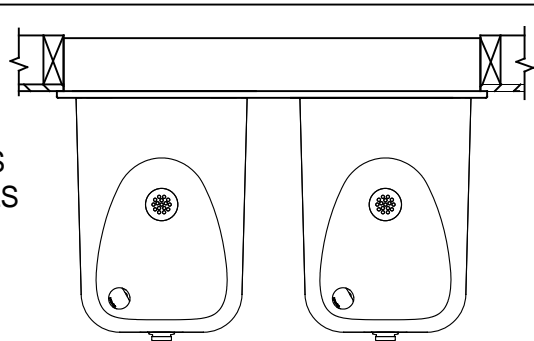

		1455 KLEPPE LANE SPARKS, NEVADA 89431 (775) 359-4712 FAX (775) 359-7424 E-MAIL: HAWS@HAWS.CO.COM WEBSITE: WWW.HAWS.CO.COM	
ECN NO. 5081	REVISED PER: ECN: 5188	BY: JP	MODEL(S)
DRAWN: MJ	DATE: 02/13/17	CHK'D.: VWC	MODEL 1920/1920HPS/1920W
APPROVED: FV	DATE: 07/06/17	SCALE: N/A	DRAWING TYPE: INSTALLATION
PART NUMBER 0510000490.D			REVISION 3
SHEET 5 OF 5			SIZE: A