

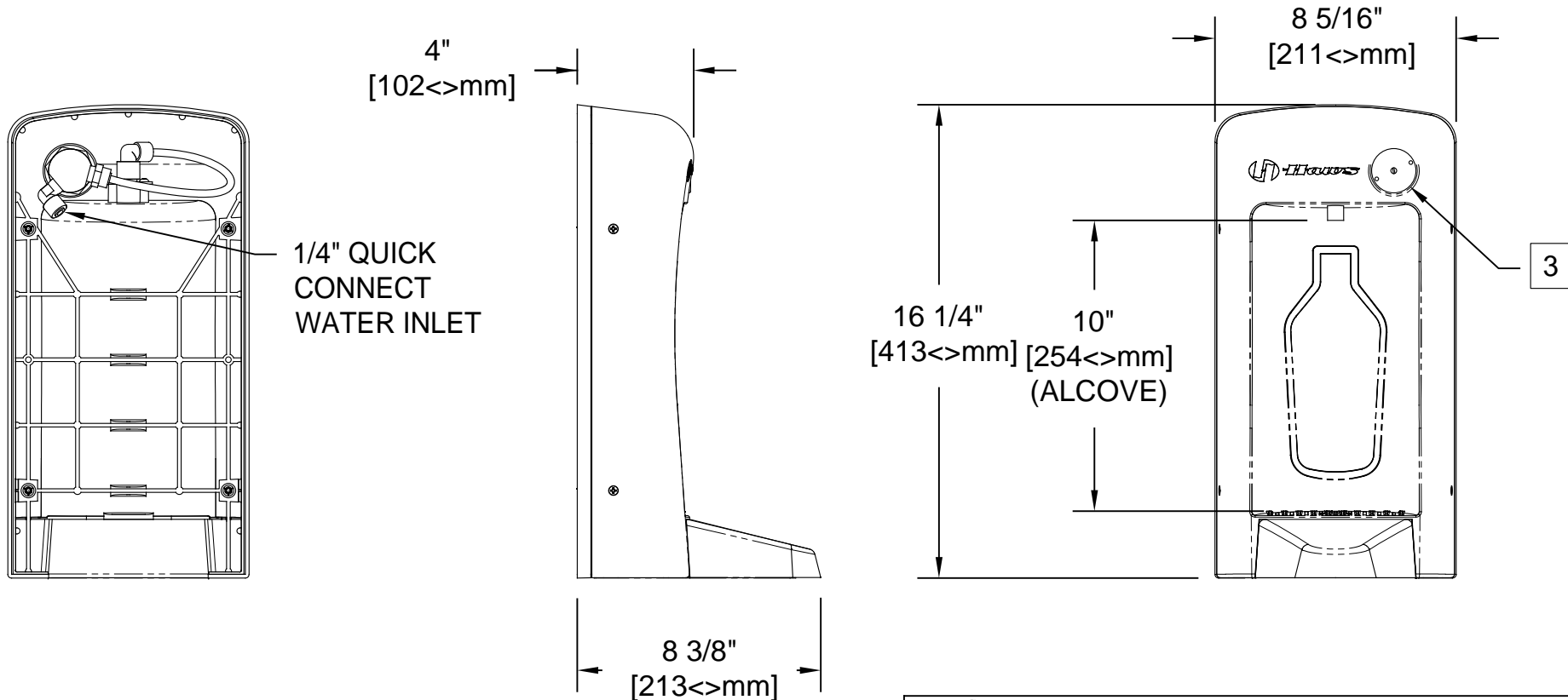

NOTES:

1. HOLD ROUGH-IN DIMENSIONS  $\pm 1/4"$  (6.4mm).
2. WHEN INSTALLING THIS UNIT, LOCAL, STATE, OR FEDERAL CODES SHOULD BE ADHERED TO. FOR INSTALLATION HEIGHTS OTHER THAN SHOWN, DIMENSIONS MARKED (\*) MUST BE ADJUSTED ACCORDINGLY. INSTALL A TRAP IN THE WASTE LINE AND A SCREWDRIVER STOP IN THE SUPPLY LINE IF REQUIRED.
- 3 REFER TO 5874 SERIES OPERATION & MAINTENANCE MANUAL FOR PUSH BUTTON AND VALVE INSTALLATION & MAINTENANCE INSTRUCTIONS.
- 4 BOTTLE FILLER IS SHOWN INSTALLED AT ADA MAXIMUM OBSTRUCTED FORWARD REACH HEIGHT. FOR ADA OBSTRUCTED SIDE REACH COMPLIANCE, BOTTLE FILLER MUST BE LOWERED 2". ADA COMPLIANCE DEPENDS ON OVERALL SIZE OF WATER COOLER OR DRINKING FOUNTAIN (SEE SHEETS 3 & 4).



		1455 KLEPPE LANE SPARKS, NEVADA 89431 (775) 359-4712 FAX (775) 359-7424 E-MAIL: HAWS@HAWS.CO.COM WEBSITE: WWW.HAWS.CO.COM	
		ECN NO. 4855 DRAWN: JL APPROVED: FV	REVISED PER: ECN: 5188 DATE: 2/10/14 DATE: 07/06/17
PART NUMBER 0002076963.D			REVISION 4
SCALE: 1:1		DRAWING TYPE: INSTALLATION	SIZE: A SHEET 1 OF 4

### DRAIN SETUP

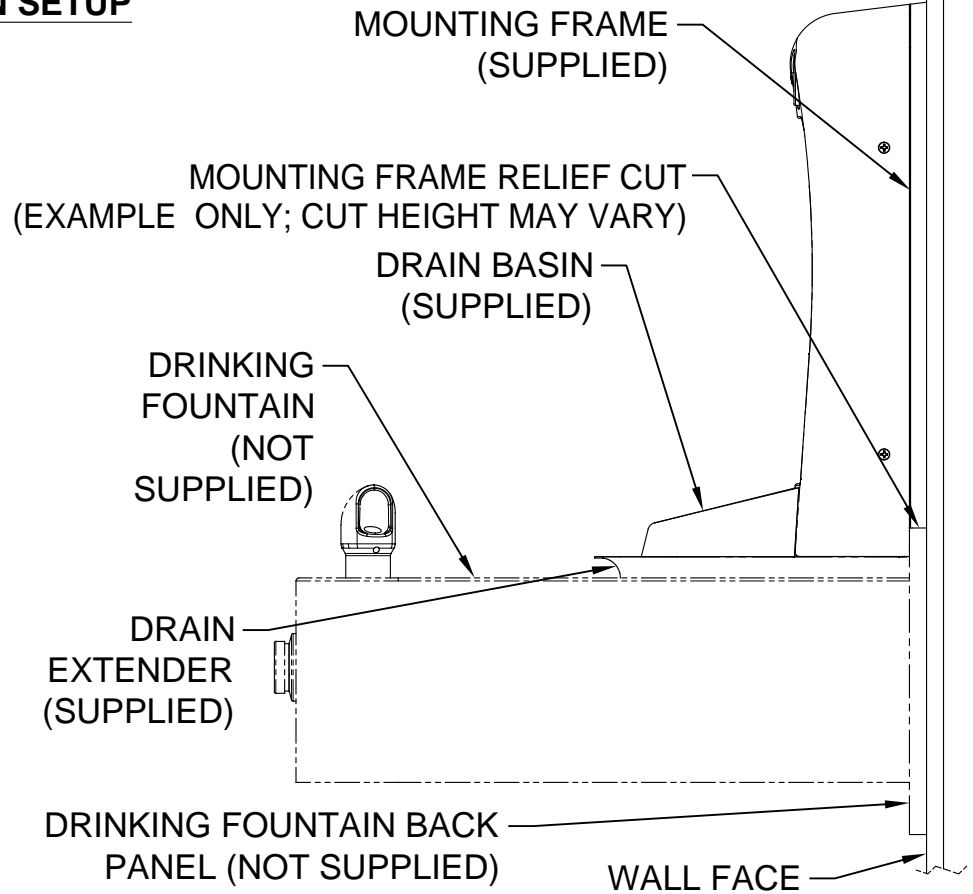
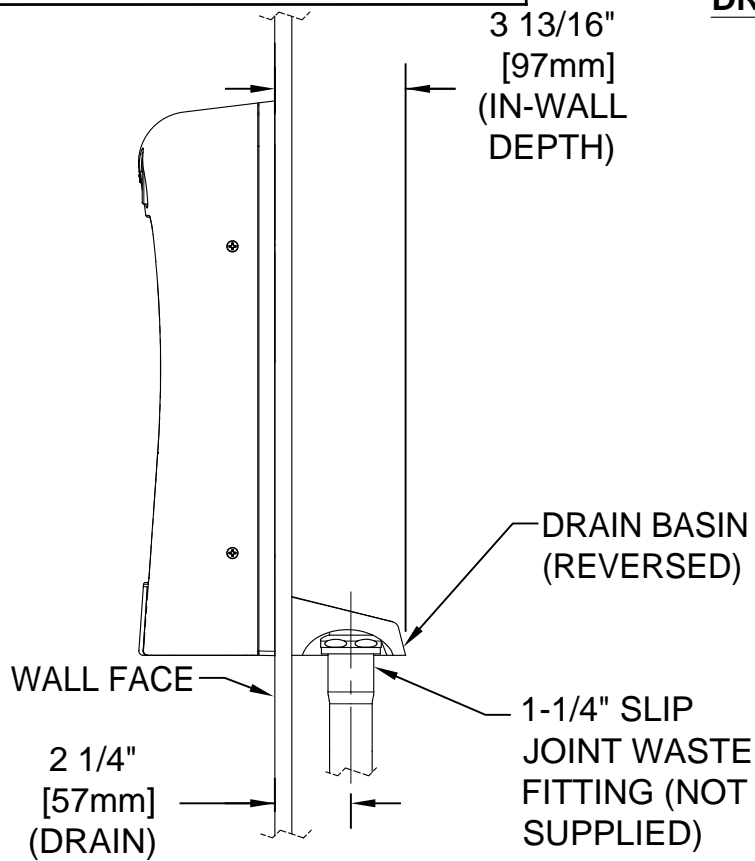

### DRAIN SEAL DETAIL

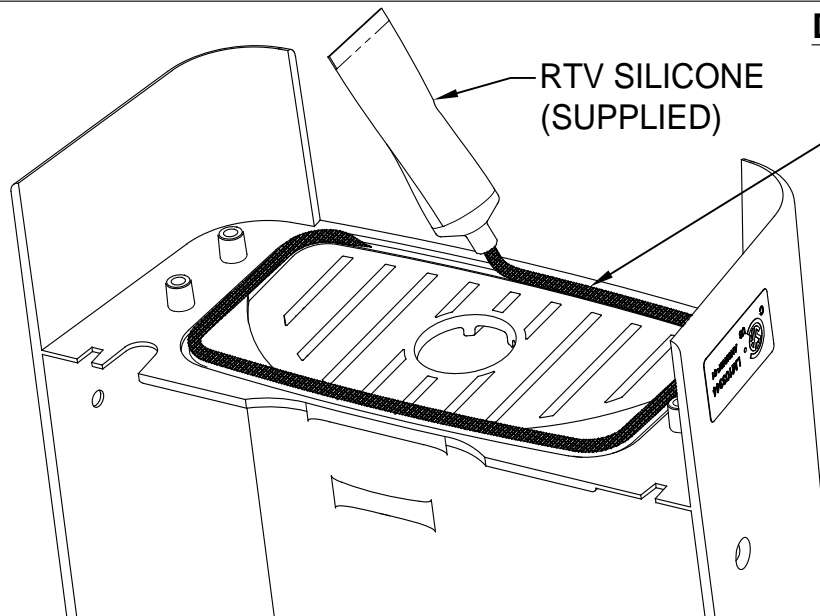

RUN A 1/8"-3/16" DIAMETER BEAD OF RTV RIGHT ALONGSIDE THE GROOVE, BUT NOT IN THE GROOVE. CHECK THE RTV BEAD FOR THIN SECTIONS, GAPS, OR AREAS WHERE THE BEAD DOES NOT TOUCH THE PLASTIC - FILL THESE IN WITH RTV.



1455 KLEPPE LANE  
SPARKS, NEVADA 89431  
(775) 359-4712 FAX (775) 359-7424  
E-MAIL: HAWS@HAWS.CO  
WEBSITE: WWW.HAWS.CO

ECN NO. 4855		REVISED PER: ECN: 5188		BY: JP	MODEL(S)		1900		PART NUMBER	
DRAWN: JL		DATE: 2/10/14		CHK'D: VWC	BOTTLE FILLER, EWC RETROFIT				0002076963.D	
APPROVED: FV		DATE: 07/06/17		SCALE: 1:1		DRAWING TYPE: INSTALLATION		SIZE: A		REVISION
										4
										SHEET 2 OF 4

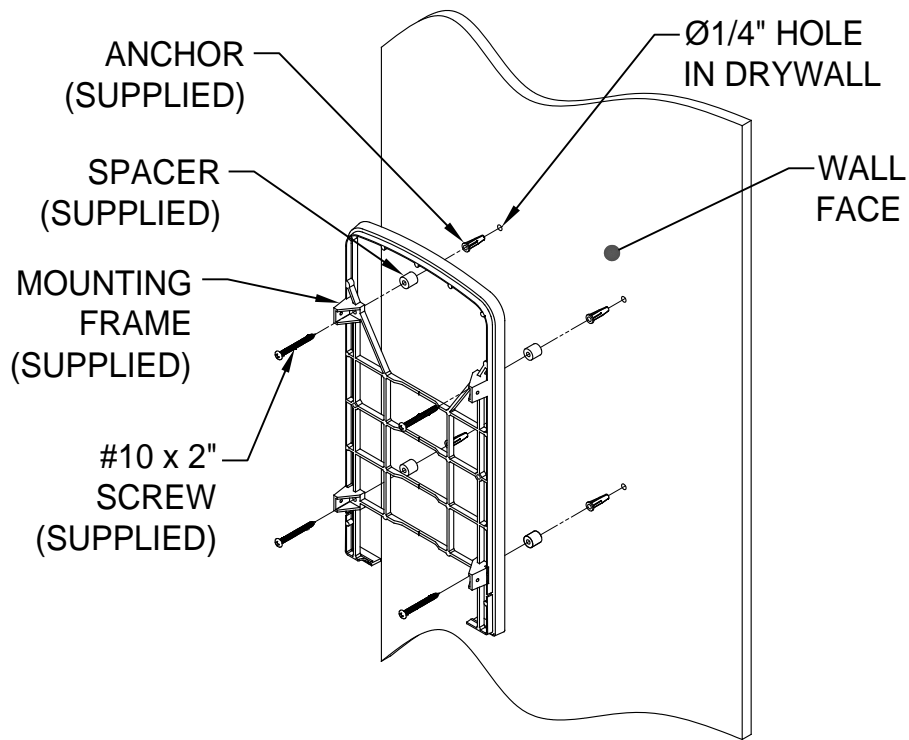

**MOUNTING FASTENER DETAIL**

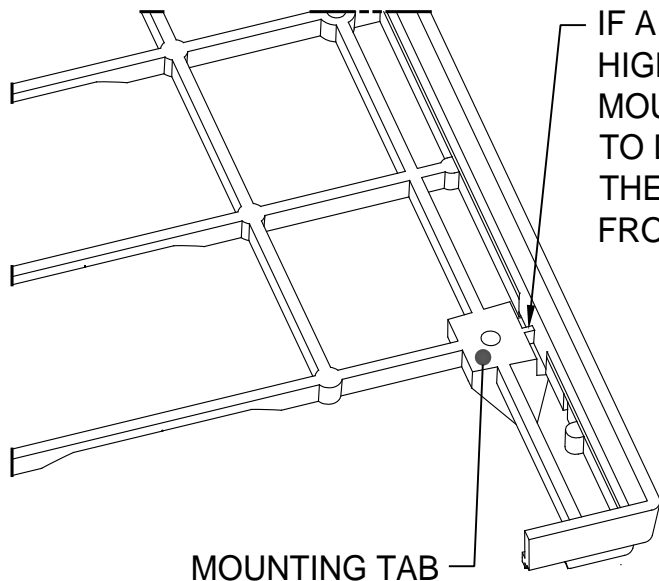

**CUTTING THE MOUNTING FRAME RELIEF**

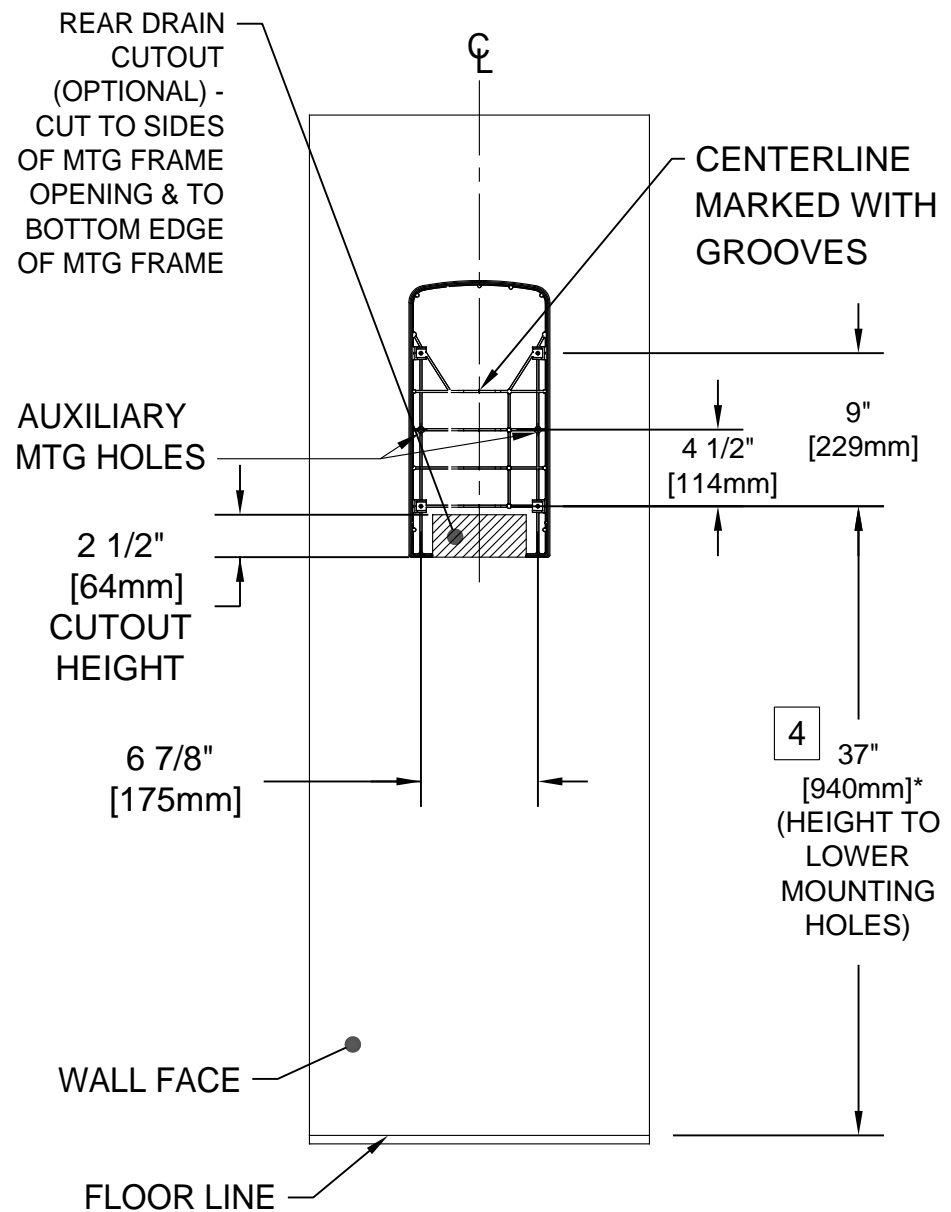

**MOUNTING FRAME & OPTIONAL REAR DRAIN CUTOUT DETAILS**

		1455 KLEPPE LANE SPARKS, NEVADA 89431 (775) 359-4712 FAX (775) 359-7424 E-MAIL: HAWS@HAWS.CO.COM WEBSITE: WWW.HAWS.CO.COM	
ECN NO. 4855 DRAWN: JL APPROVED: FV	REVISED PER: ECN: 5188 DATE: 2/10/14 DATE: 07/06/17	BY: JP CHKD.: VWG	MODEL(S) 1900 BOTTLE FILLER, EWC RETROFIT
SCALE: 1:1   DRAWING TYPE: INSTALLATION			PART NUMBER: 0002076963.D REVISION: 4
SHEET 3 OF 4			SIZE: A

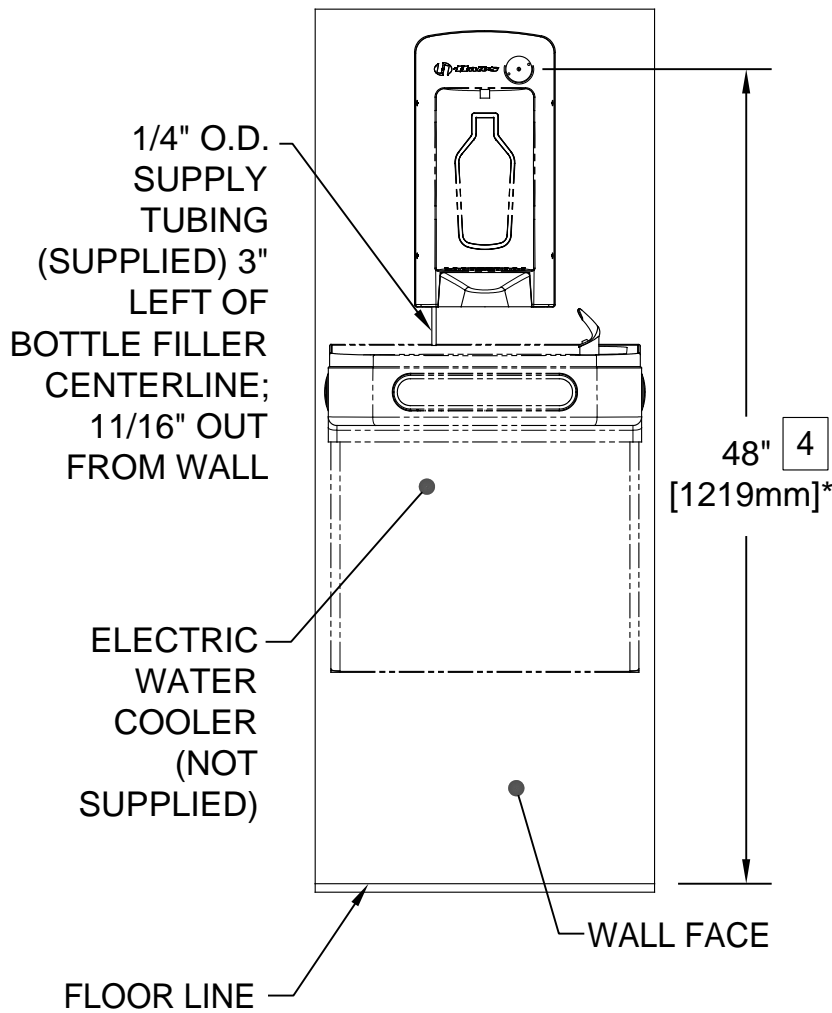

**TYPICAL WATER COOLER INSTALLATION**

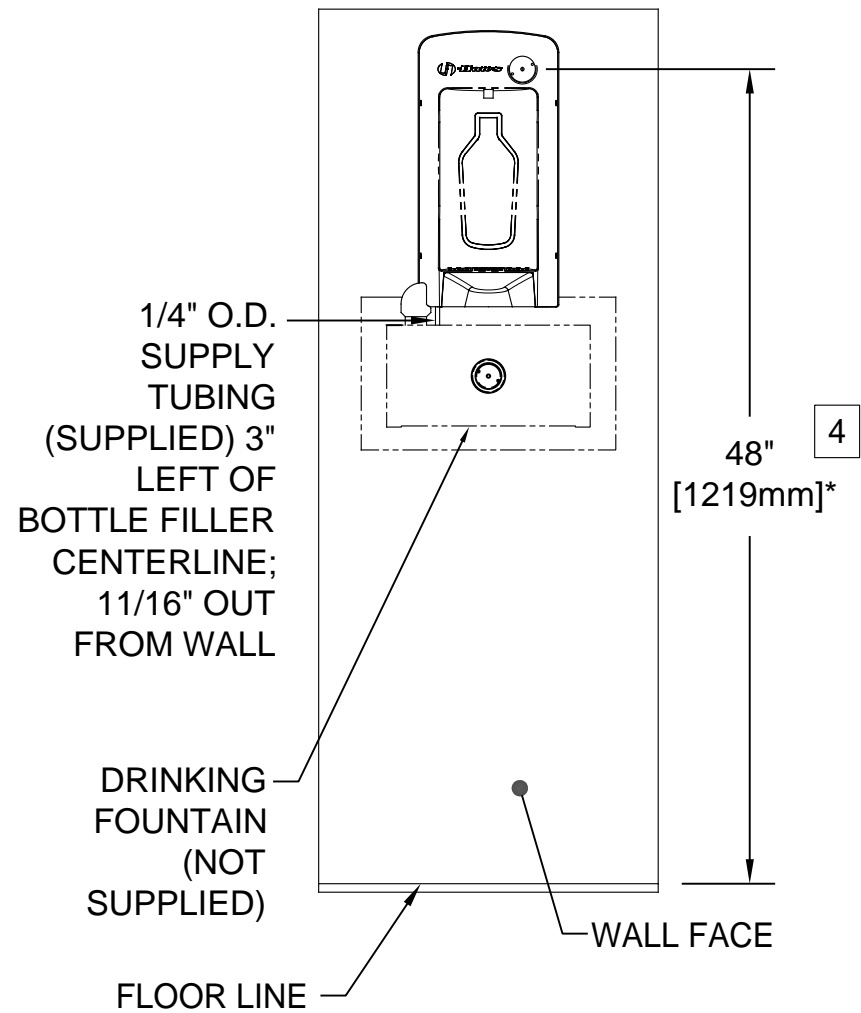

**TYPICAL DRINKING FOUNTAIN INSTALLATION**

		<b>Haws</b> <sup>®</sup>		1455 KLEPPE LANE SPARKS, NEVADA 89431 (775) 359-4712 FAX (775) 359-7424 E-MAIL: HAWS@HAWSO.COM WEBSITE: WWW.HAWSO.COM	
				ECN NO. 4855 DRAWN: JL APPROVED: FV	REVISED PER BY: JP ECN: 5188 DATE: 2/10/14 DATE: 07/06/17
SCALE: 1:1		DRAWING TYPE: INSTALLATION		SIZE: A SHEET 4 OF 4	