

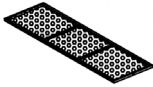

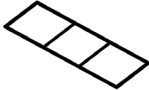



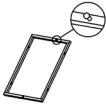
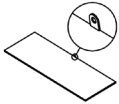
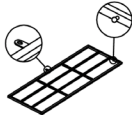

I - PART AND HARDWARE LIST:

PIECE	DESCRIPTION	PICTURE	QTY
A	Bottom frame		1
B	Back frame		1
C	Left frame		1
D	Right frame		1
E	Front frame		1
F	Top frame		1
G	Piston 100N		1
H	Bolt M6x30		18
I	Bolt M6x15		6
J	Washer		24
K	Plastic feet		6
L	Allen Key 4		1

happimesseTM

MODEL #TRK1002-HAPPIMESS STORAGE TRUNK (LARGE)

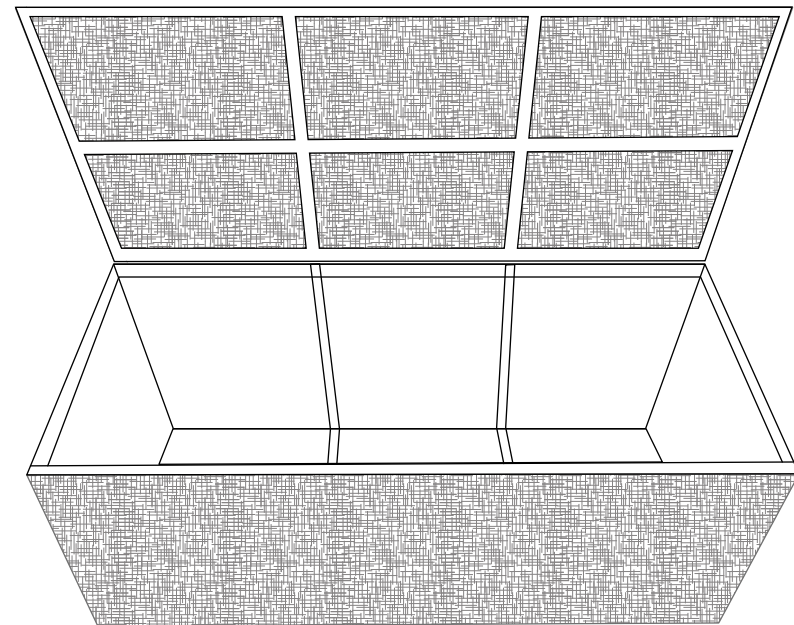

If there are any questions related to defects, missing parts, assembly issues or replacements, please send a detailed email to hello@happimesse.com

II- PRODUCT ASSEMBLY: "DO NOT TIGHTEN THE SCREWS UNTIL ALL OF PARTS SET INTO CORRECT POSITION"

1

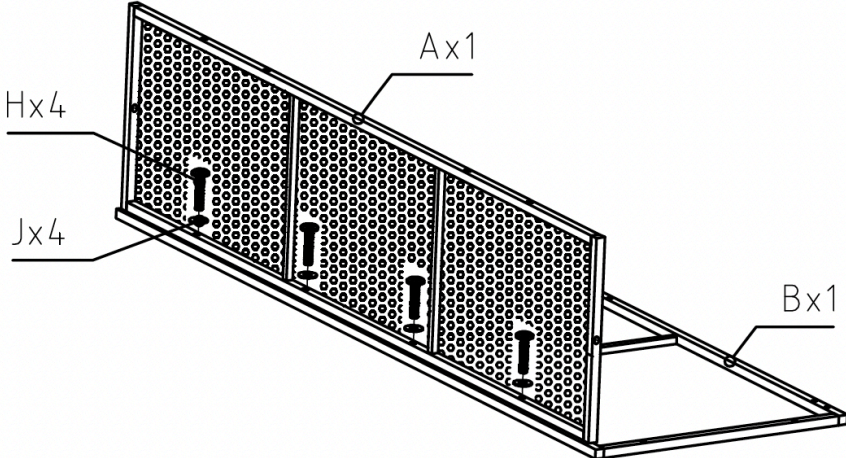

2

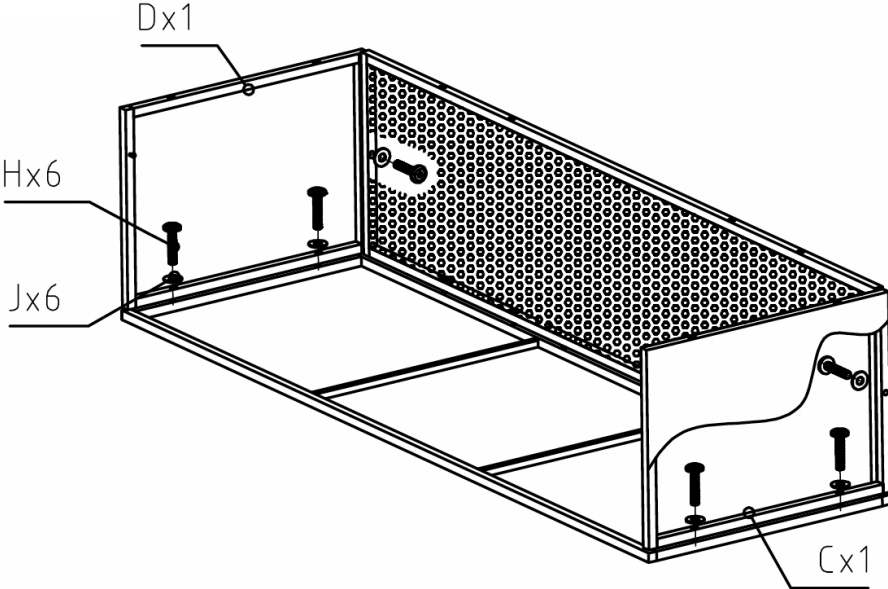

II- PRODUCT ASSEMBLY: "DO NOT TIGHTEN THE SCREWS UNTIL ALL OF PARTS SET INTO CORRECT POSITION"

3

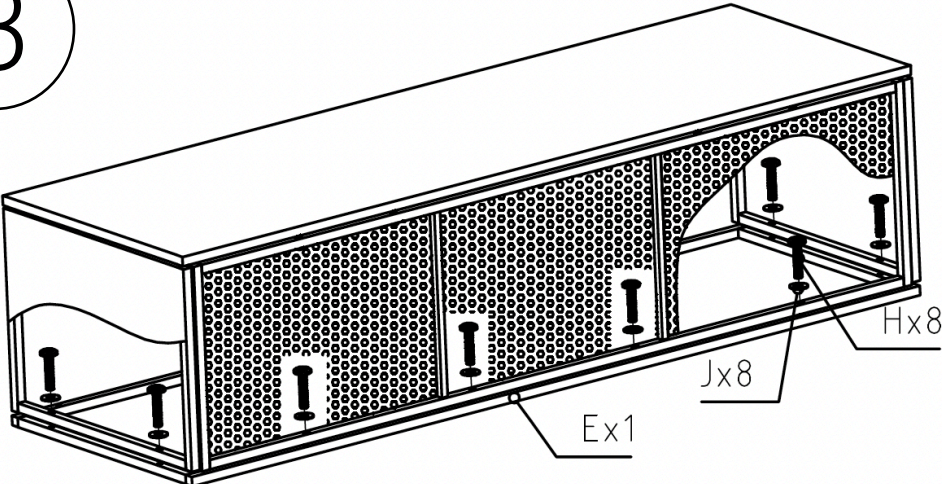

4

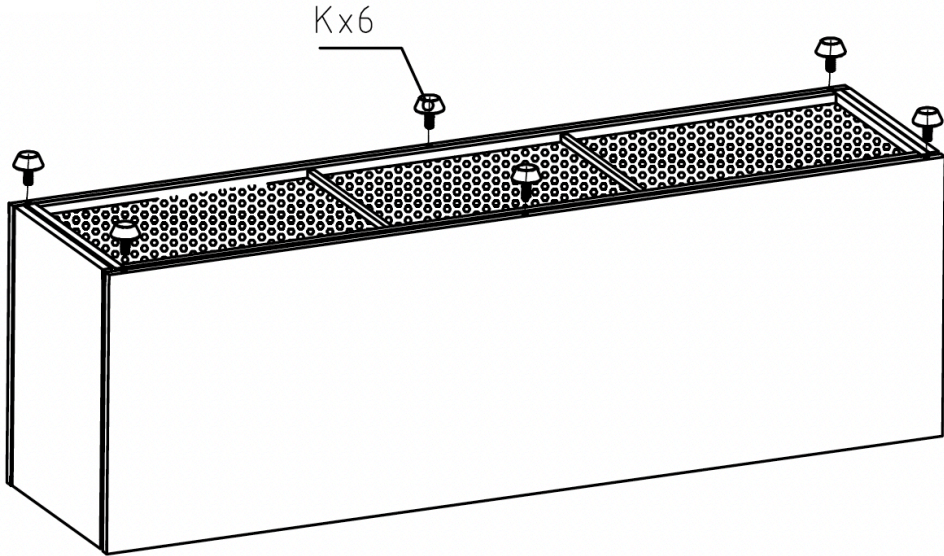

II- PRODUCT ASSEMBLY: "DO NOT TIGHTEN THE SCREWS UNTIL ALL OF PARTS SET INTO CORRECT POSITION"

