

HANOVER[®]

Hanover Outdoor Furniture



IMPORTANT

If you have any problems with this product (missing or damaged parts, assembly issues, etc.),

PLEASE DO NOT RETURN TO THE RETAILER/STORE

from where you purchased the product.

Please call our Toll-Free Customer Service Hotline at: **1-866-851-8438**







Between 9:00 AM and 5:00 PM Eastern Time, Monday through Friday

Or visit our website at: **www.hanover-products.com**

To expedite any future warranty claims, please retain the Instruction Sheet, Warranty Card and receipt for future use.

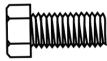
For additional on-line support on assembly, troubleshooting and care & maintenance of your outdoor furniture, please visit our website at: **www.hanover-products.com**.

PARTS LIST

PART#	DESCRIPTION	PICTURE	Q'TY
A	Table Top		1
B	Table Leg		4
C	Support Tube		4
D	Bolt M6x20		4
E	Bolt M6x35		12
F	Washer		16
G	Bolt Cover		16
H	Open Wrench		1

Assembly Steps:

Note: Do not fully tighten bolts until assembly is completed and alignment is correct.

Step 1. Carefully place the table top (A) upside down on a non-abrasive surface.

Step 2. Assemble the table legs (B) to the table top (A) with bolts (D&E) and washer (F) as shown in figure 1.

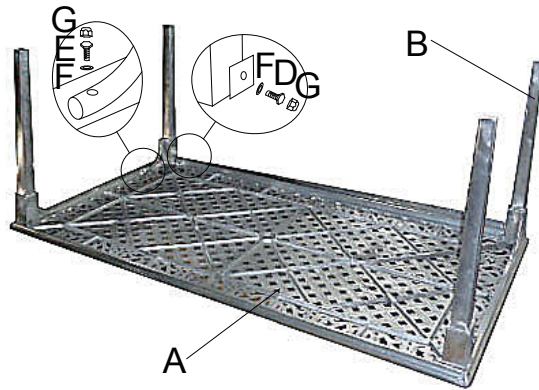

Figure 1

Step 3. Loosely attach the support bar (C) to the table leg (B) and table top (A) with bolts (E) and washer (F) as shown in figure 2.

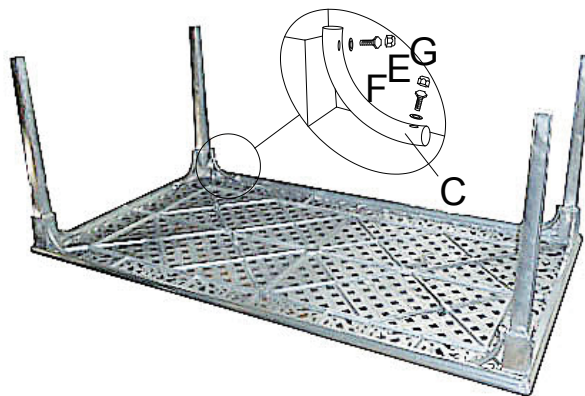

Figure 2

Step 4. Check the alignment and adjust if necessary. Once the alignment is correct, tighten all bolts with open wrench (H) . Cover all bolts with bolt caps(G).

Step 5. Verify all bolts are securely tightened before use and turn your table right side up. Your table is now ready to use. (Figure 3).



Figure 3