

**Step 1**

Lay back assembly on the floor  
 Attach the side frames with (4) 2 1/4" bolts  
 Do not tighten bolts yet fig.1

**Step 2**

Insert (2) pins into pre-drilled holes  
 on the back assembly. fig.1

**Step 3**

Set bench upright. First, attach the front  
 part of the seat using (2) 2 1/4" bolts. fig.2

**Step 4**

Push the rear part of the seat up into  
 the pins located on the back assembly.  
 Attach the rear of the seat using  
 (2) 2 1/4" bolts. fig. 2

Tighten all bolts at this time

- (2) Sideframe
- (1) Seat
- (1) Back
- (1) Hardware pack

**TOOLS NEEDED**



4mm HEX KEY, ALLEN, T-HANDLE  
 (INCLUDED)

Qty.	Description
------	-------------

2	A - 5/16 PLASTIC PINS
---	-----------------------



8	B - 1/4-20 X 2-1/4 WAFER SHCS
---	-------------------------------

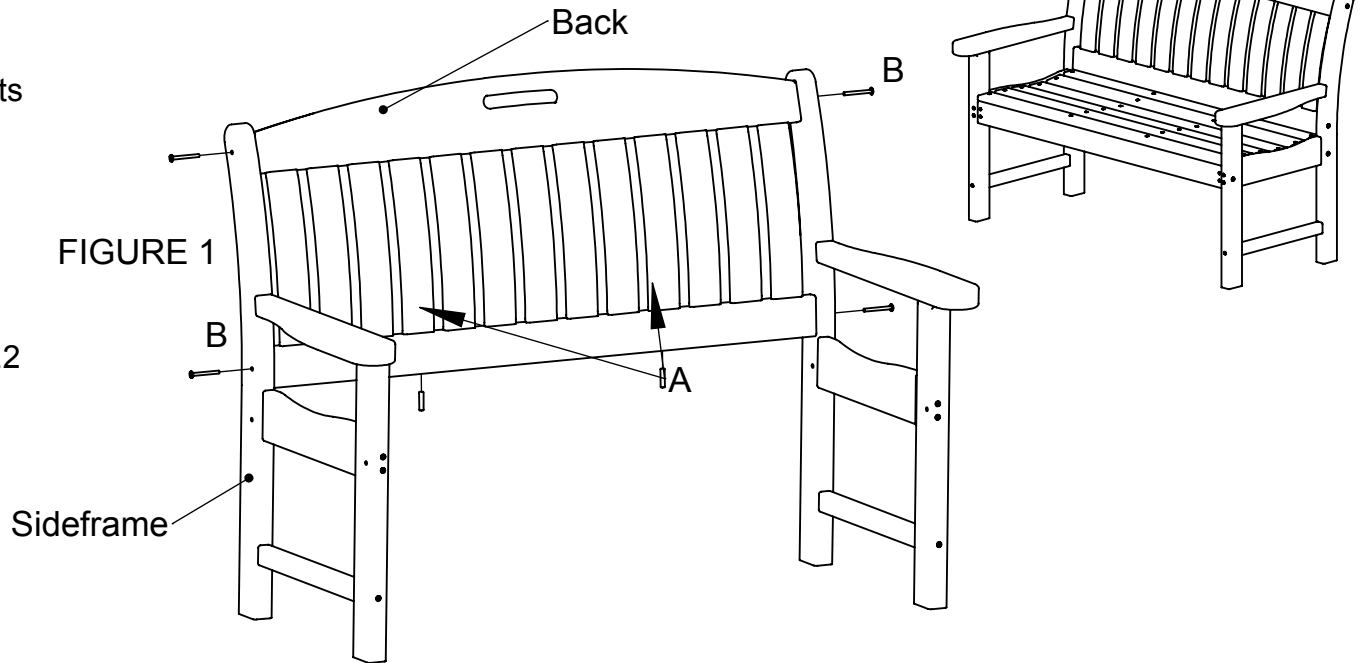

FIGURE 1

FIGURE:2

