

Step 1

Lay back assembly on the floor
Attach the side frames with (4) 2 1/4" bolts
Do not tighten bolts yet fig.1

Step 2

Insert (2) pins into pre-drilled holes
on the back assembly. fig.1

Step 3

Set bench upright. First, attach the front
part of the seat using (2) 2 1/4" bolts. fig.2

Step 4

Push the rear part of the seat up into
the pins located on the back assembly.
Attach the rear of the seat using
(2) 2 1/4" bolts. fig. 2

Tighten all bolts at this time

- (2) Sideframe
- (1) Seat
- (1) Back
- (1) Hardware pack

TOOLS NEEDED



4mm HEX KEY, ALLEN, T-HANDLE
(INCLUDED)

Qty.	Description
------	-------------

2	A - 5/16 PLASTIC PINS
---	-----------------------



8	B - 1/4-20 X 2-1/4 WAFER SHCS
---	-------------------------------



ASSEMBLY INSTRUCTIONS

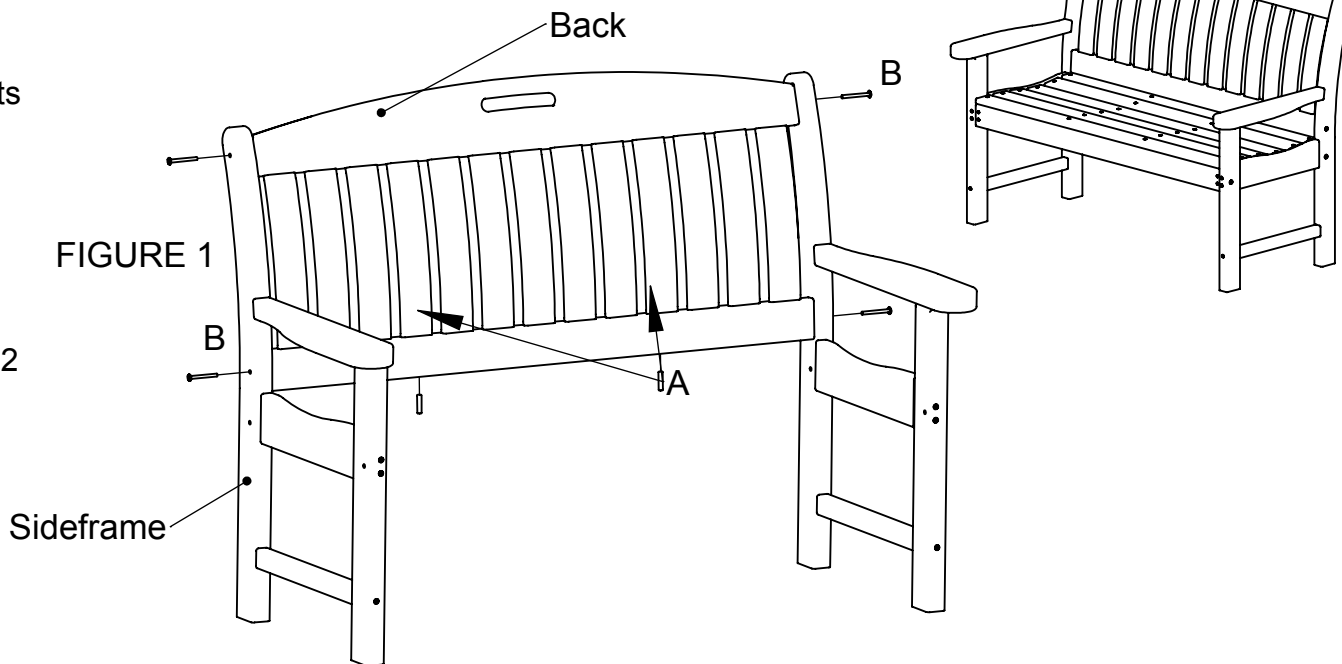

FIGURE 1

FIGURE:2

