

HANOVER®

MODEL: HVLNA10

- (1) Seat
- (1) Back
- (2) Front legs
- (2) Arms
- (1) Long brace
- (1) Short brace
- (1) Hardware pack

TOOLS NEEDED

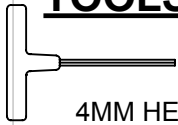

4MM HEX KEY, ALLEN, T-HANDLE (INCLUDED), 7/16 WRENCH

STEP 1

Attach Front Legs to Seat using (6) 1-7/8" bolts, nuts and washers.

Attach Front and Rear Brace using (4) 2" screws.

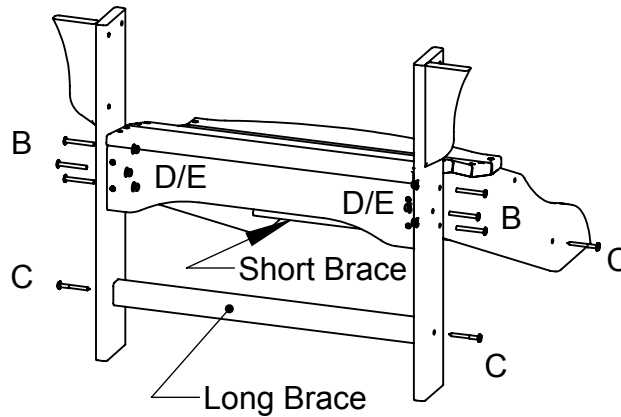

STEP 2

Attach Arms to Front Legs using (2) 2-1/4" bolts, nuts and washers.

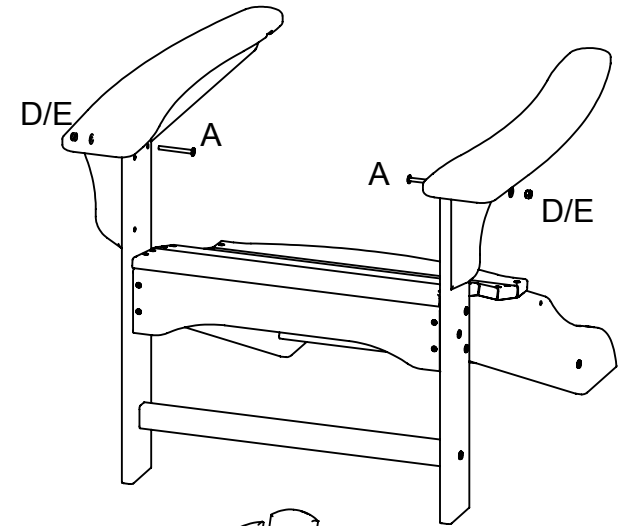

STEP 3

Attach Back to Seat and Arms using (4) 2" screws

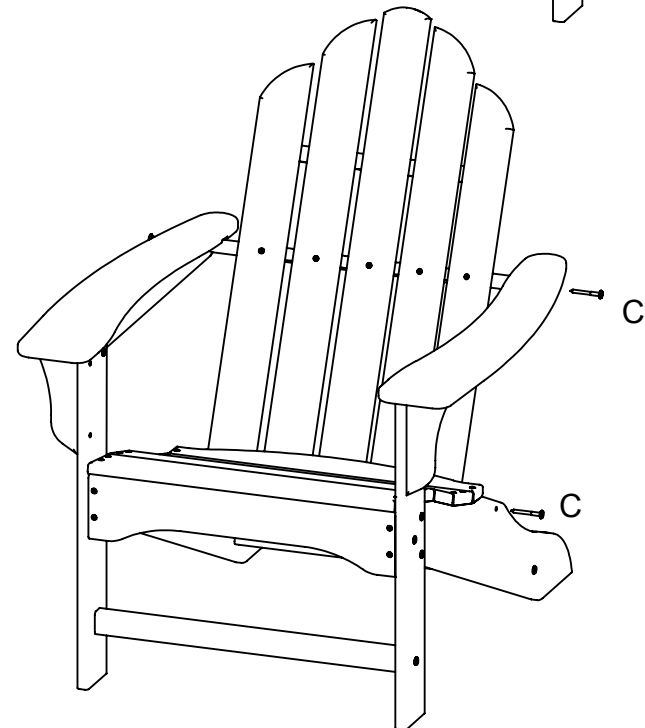

QTY	DESCRIPTION
2	A-1/4-20 X 2-1/4 WAFER SHCS
6	B-1/4-20 X 1-7/8 WAFER SHCS
8	C-.273 X 2.00 SOCKET WAFER A
8	D-1/4-20 NYLOCK NUT
8	E-1/4 FLAT WASHER

