

HANOVER®

MODEL: HVLNA15

- (1) Seat
- (1) Back
- (2) Front legs
- (2) Arms
- (1) Long brace
- (1) Short brace
- (1) Hardware pack

TOOLS NEEDED

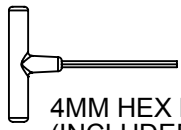

4MM HEX KEY, ALLEN, T-HANDLE (INCLUDED), 7/16 WRENCH

Step 1
Attach short brace to rear legs using (2) 2" screws

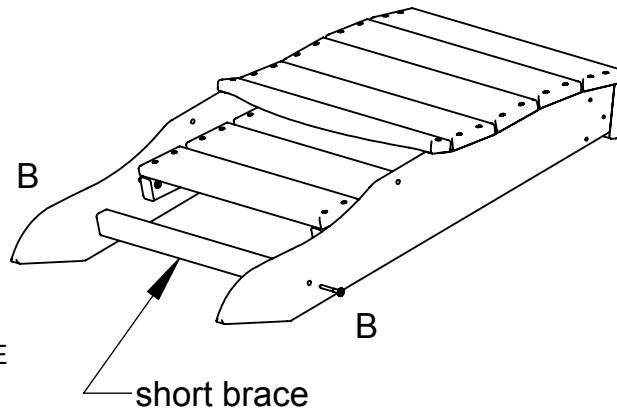

WING
FACES
FRONT

Step 2
Attach front legs to seat using (6) 1½" screws

Attach long brace using (2) 2" screws

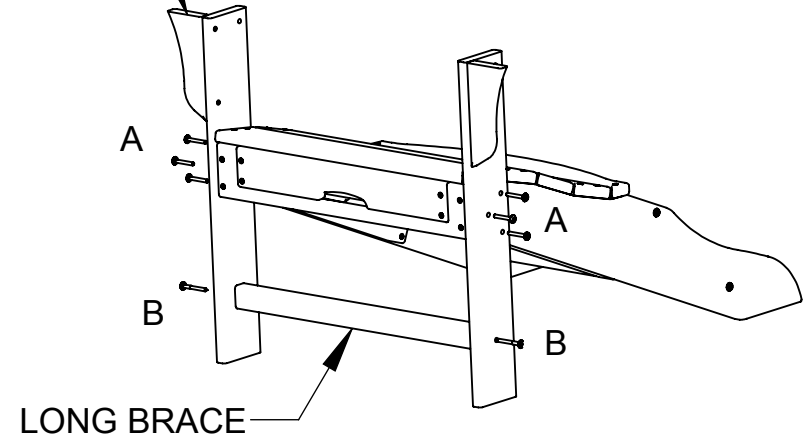

Step 4
Attach back to seat using (2) 2" screws

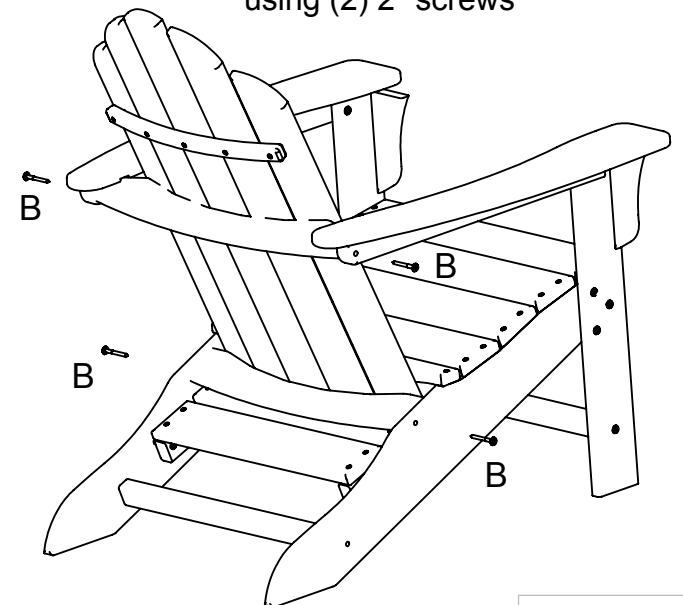

Attach back to arm using (2) 2" screws

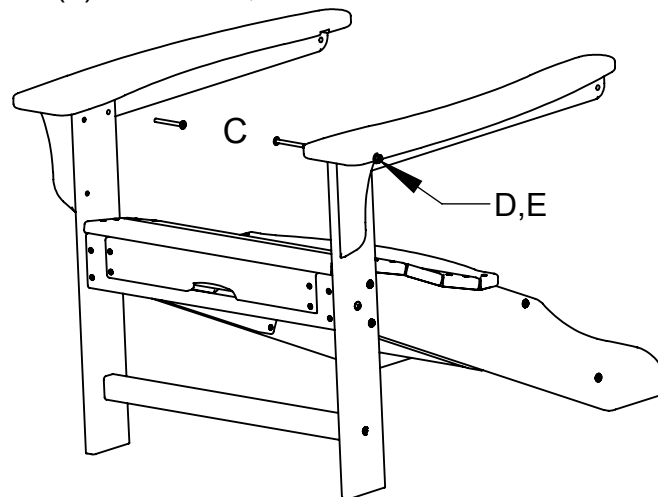

Step 3
Attach arms to front leg using (2) 2-1/4" bolt, nut and washer

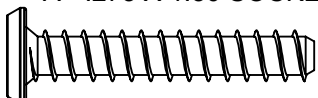

QTY. DESCRIPTION

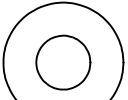
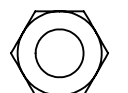
- | | |
|---|---|
| | A - .273 X 1.50 SOCKET WAFER B |
| 6 |  |
| | B - .273 X 2.00 SOCKET WAFER A |
| 8 |  |
| | C-1/4-20 X 2-1/4 WAFER SHCS |
| 2 |  |
| | D-1/4 FLAT WASHER |
| 2 |  |
| | E-1/4-20 NYLOCK NUT |
| 2 |  |