

Collection: GLACIER

Product #: CHB0061-2B

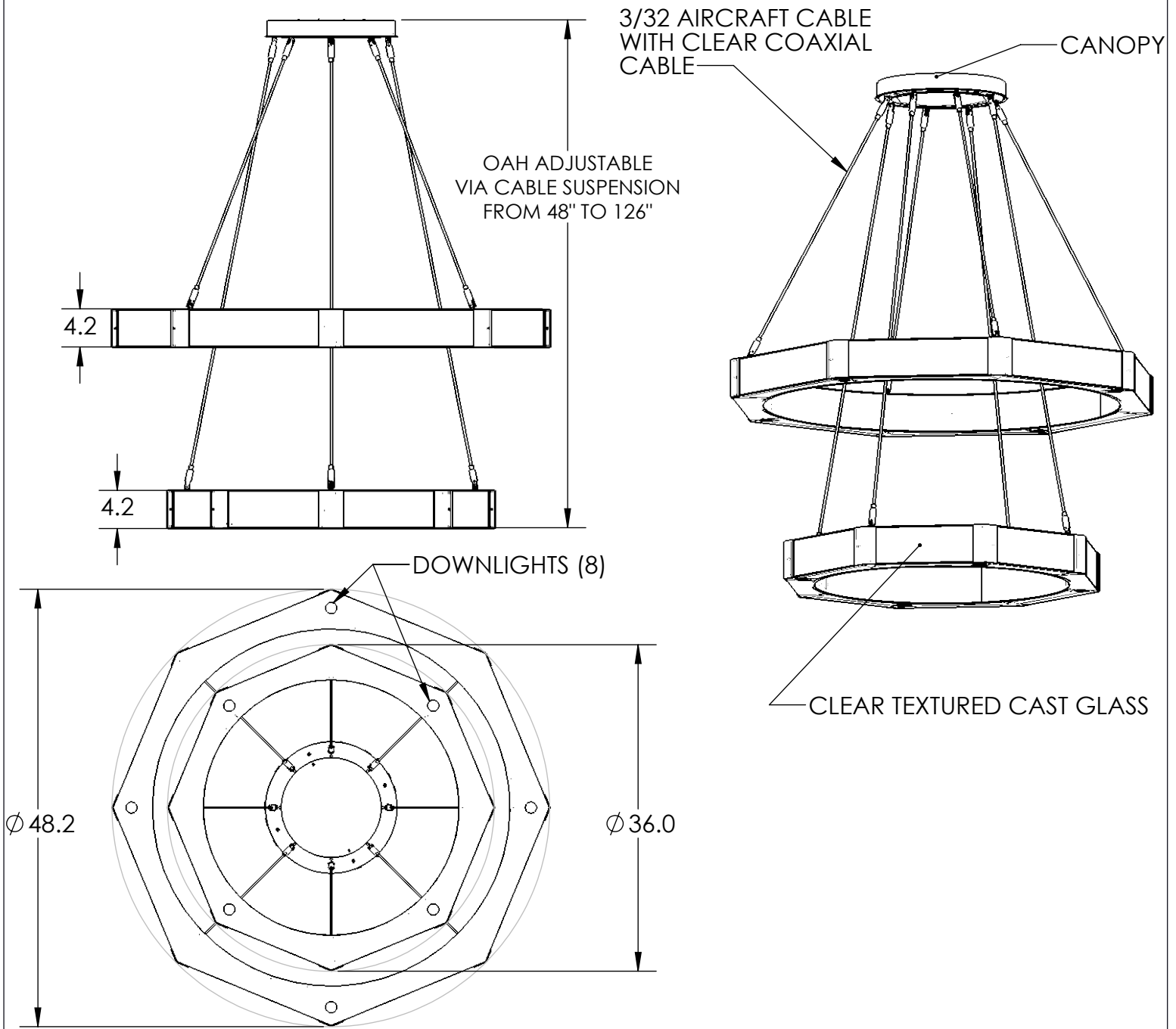

ALL DIMENSIONS ARE IN INCHES UNLESS OTHERWISE STATED  
 Visit [hammertonstudio.com](http://hammertonstudio.com) for product options and specifications.

2/5/2020 (A)

Mounting Packet: A	Weight(lbs.): 198	Electrical Type: LED	CCT: 2700 K
UL Location: DRY		Elec. Qty: 40	Wattage: 126 Voltage: 120
Finish: SEE WEB SITE FOR OPTIONS		Lumens: Ambient: 2720	Down: 2720
Top Diffuser: CLOSED METAL		Dimmable: Forward/Reverse Phase To 1%	
Bottom Diffuser: FROSTED ACRYLIC		CRI: 93+	Power Factor: >0.9

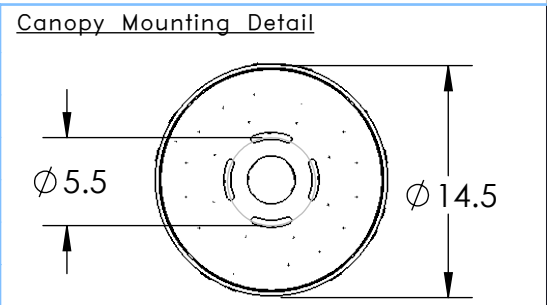

All fixtures created by Hammerton are handcrafted by artisans. Dimensions may vary up to 7/8".  
 © Copyright 2020. All rights in design, detail or invention of this drawing are reserved as the property of Hammerton. Any imitation or adaptation without written consent is strictly prohibited.

MOUNTS TO BUILDING STRUCTURE