



PRODUCT DESCRIPTION

Our best-selling outdoor fixture, this versatile contemporary sconce features a nested box design with a frosted seeded glass inner lens, a clear seeded glass outer lens and an open bottom. AC LED lamping minimizes energy consumption and fixture maintenance.

The Double Box sconce is certified by the International Dark Sky Association (IDA) to avoid night sky pollution, reduce light trespass and minimize glare. It is offered in three AAMA 2604-rated finishes that withstand UV and corrosion resistance in coastal and other harsh climates, and it includes a lifetime warranty to the original purchaser.

SCAN FOR MORE INFORMATION

All dimensions are shown in inches unless otherwise stated.

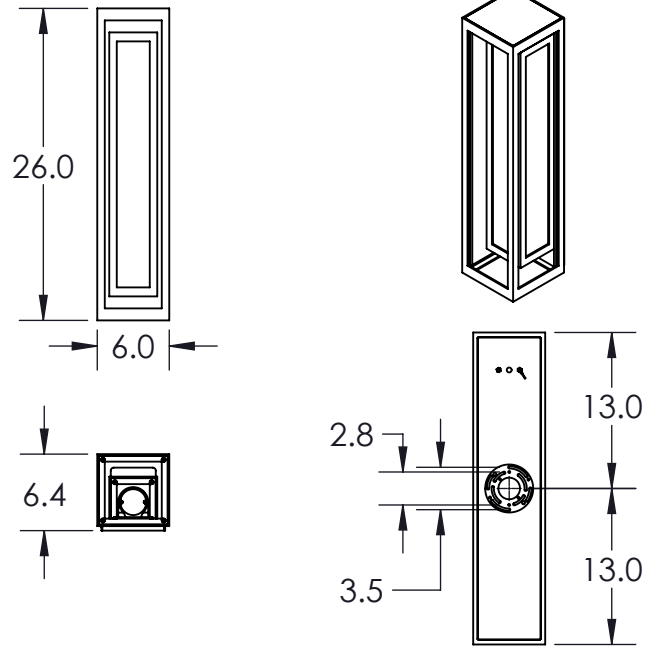

Mounting Method: J-Box Wall Mount

PRODUCT SPECIFICATION

Construction: Aluminum Body With Glass Panes

Finish Options: **AG** **SB** **TB**

Glass Type: **CS** + **F**

Suspension Method: Wall Mount

Weight(lbs.): 15

UL Rating: Wet

Top Diffuser: Closed

Bottom Diffuser: Open

Light Source: LED

Electrical Qty: 1

Wattage (Watts): 4.5

Voltage (Volts): 120

Source Lumens: 400

Dimming: ELV to 1%

CCT: 3000K

Driver Quantity & Location: 0

CRI: 93+

Power Factor: >0.9

Notes:

GENERAL NOTES:

Visit studio.hammerton.com to read about our Lifetime Limited Warranty.

All Hammerton fixtures are handcrafted by artisans. Subtle imperfections reflect the mark of the artisan and should be expected in any handcrafted product. Dimensions may vary up to 7/8".

Rev © 2/25/2022