

Collection: HEDRA

Product #: LAB0045-01

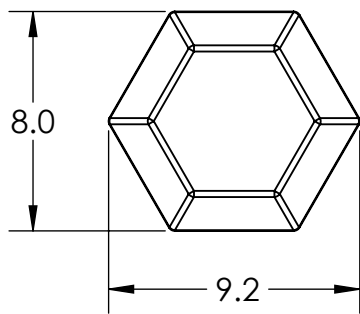
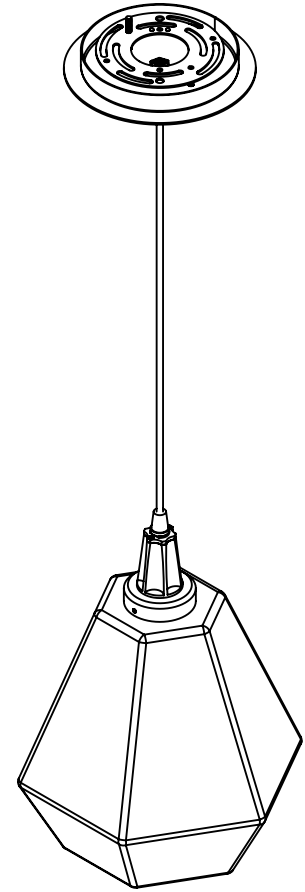
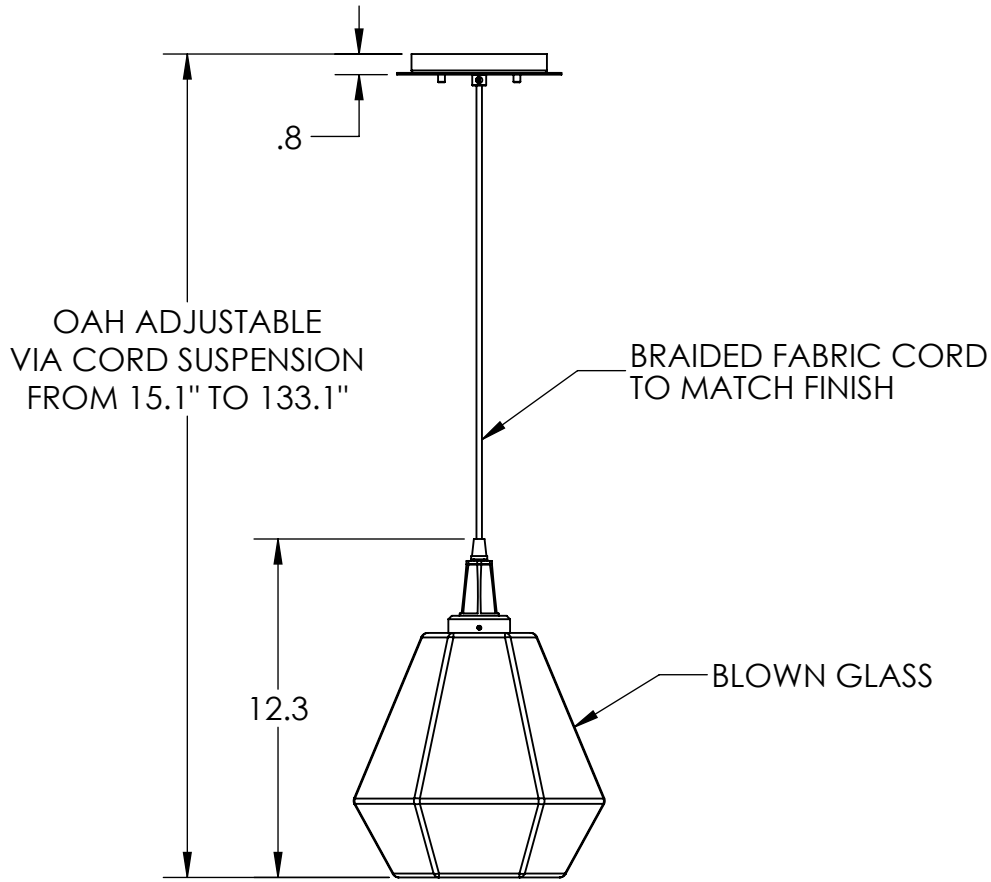

****NOTE****
 DRIVER TO BE INSTALLED IN J-BOX
 MINIMUM SIZE OF J-BOX REQUIRED IS
 4" L x 4" W x 1.5" H

Visit hammertonstudio.com for product options and specifications.

12/8/2016 (A)

Mounting Packet: Y	Weight(lbs.): 6	Electrical Type: LED	CCT: 2700 K
UL Location: DRY	Elec. Qty: 1	Wattage: 5.2	Voltage: 120
Finish: SEE WEB SITE FOR OPTIONS	Source Lumens:	Up: N/A	Down: 340
Top Diffuser: CLOSED	Dimmable:	Forward/Reverse Phase or 0-10V To 1%	
Bottom Diffuser: CLOSED GLASS	CRI: 93+	Power Factor: >0.9	

All fixtures created by Hammerton are handcrafted by artisans. Dimensions may vary up to 7/8".

© Copyright 2016. All rights in design, detail or invention of this drawing are reserved as the property of Hammerton. Any imitation or adaptation without written consent is strictly prohibited.

Hammerton Inc. 217 Wright Brothers Dr. Salt Lake City, UT 84116 (801)973-8095

Mounting Detail

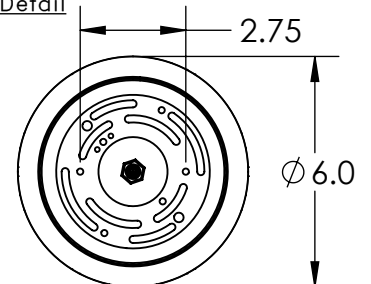

MOUNTS DIRECTLY TO J-BOX