

Collection: GLACIER

Product #: PLB0060-07

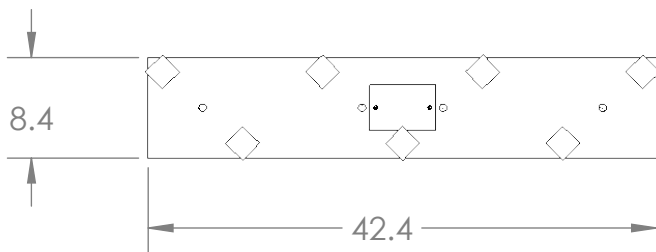
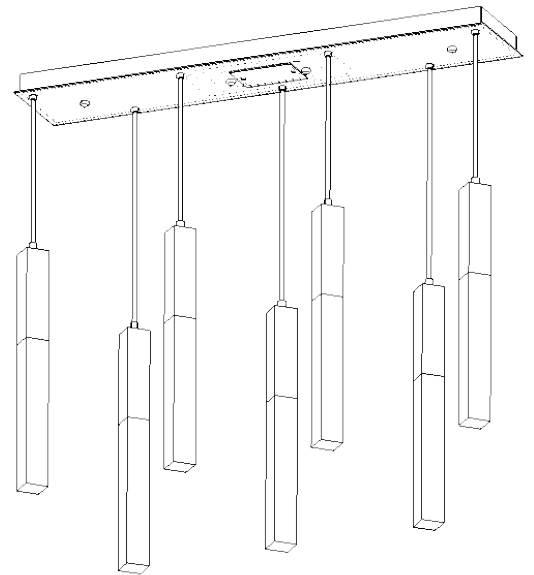
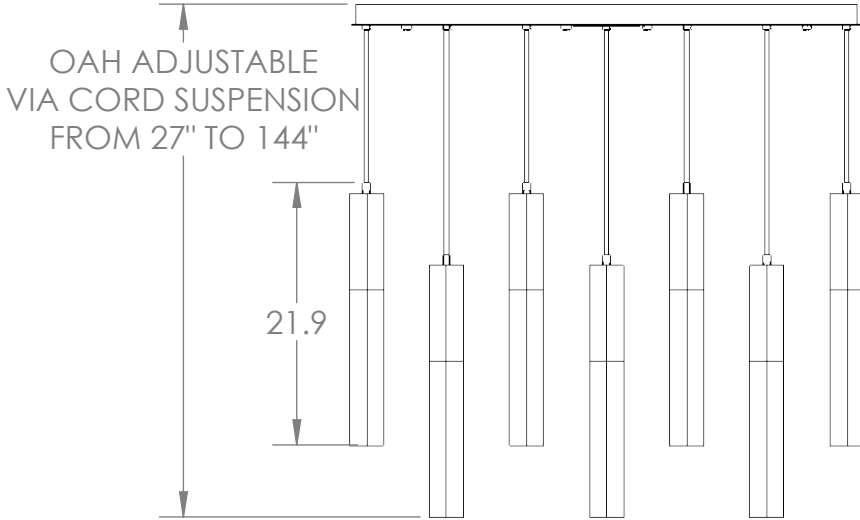

Visit hammertonstudio.com for product options and specifications.

12/12/2018 (A)

Mounting Packet: R	Weight(lbs.): 68	Electrical Type: LED	CCT: 2700 K
UL Location: DRY	Elec. Qty: 7	Wattage: 27	Voltage: 120
Finish: SEE WEB SITE FOR OPTIONS	Source Lumens: Up: 0	Down: 2395	
Top Diffuser: CLOSED METAL	Dimmable: Forward/Reverse Phase To 1%		
Bottom Diffuser: CLOSED GLASS	CRI: 93+	Power Factor: >0.9	

Mounting Detail

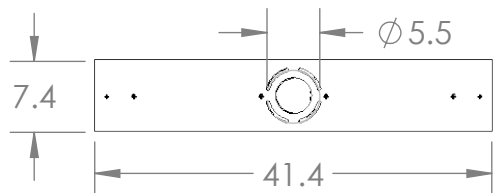

All fixtures created by Hammerton are handcrafted by artisans. Dimensions may vary up to 7/8".

© Copyright 2018. All rights in design, detail or invention of this drawing are reserved as the property of Hammerton. Any imitation or adaptation without written consent is strictly prohibited.

Hammerton Inc. 217 Wright Brothers Dr. Salt Lake City, UT 84116 (801)973-8095

MOUNTS TO BUILDING STRUCTURE