

Collection: GLACIER

Product #: CHB0060-2B

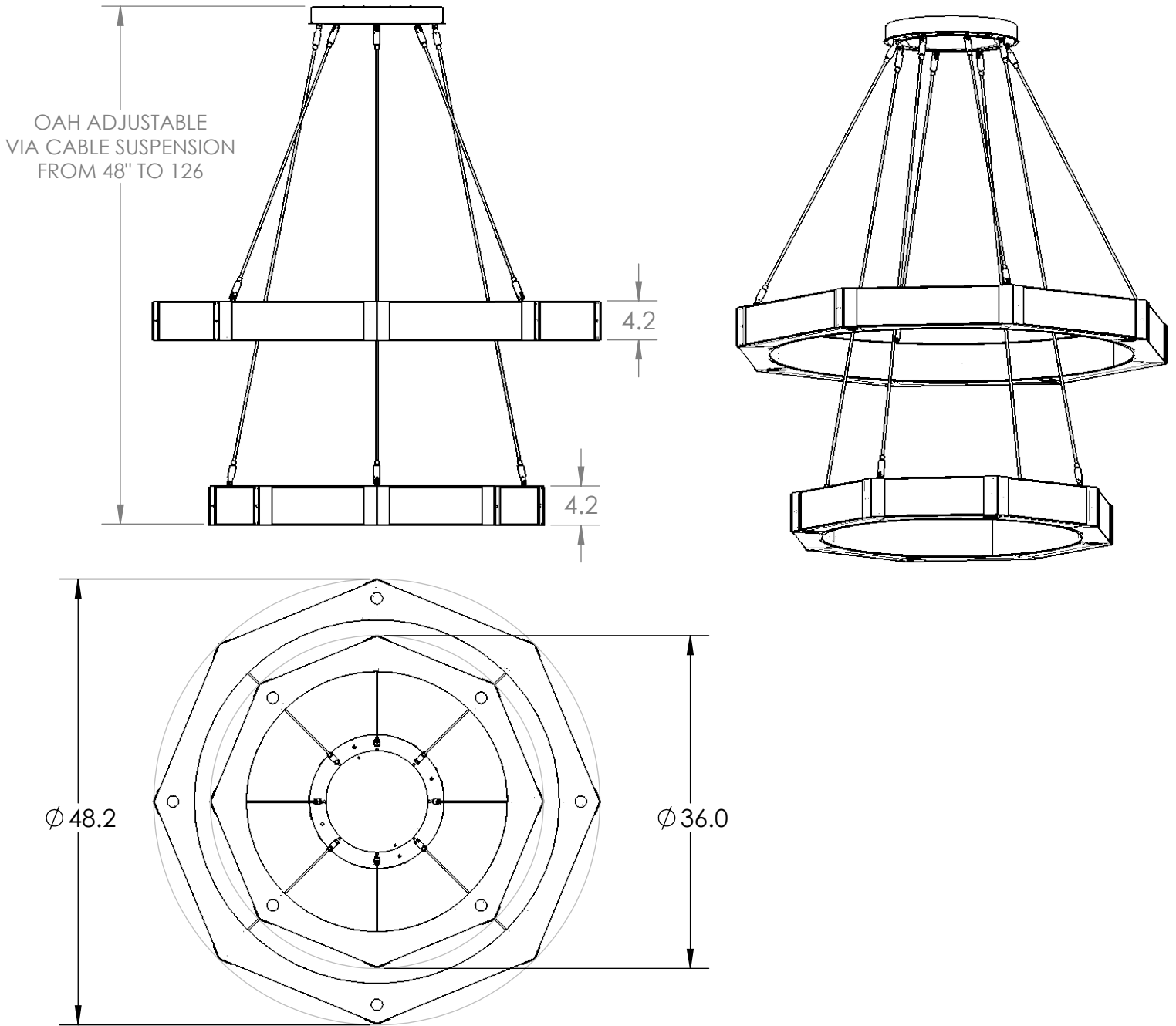

Visit hammertonstudio.com for product options and specifications.

4/30/2019 (A)

Mounting Packet: S	Weight(lbs.): 198	Electrical Type: LED	CCT: 2700 K
UL Location: DRY		Elec. Qty: 40	Wattage: 126 Voltage: 120
Finish: SEE WEB SITE FOR OPTIONS		Lumens: Ambient: 2720	Down: 2720
Top Diffuser: CLOSED METAL		Dimmable: Forward/Reverse Phase To 1%	
Bottom Diffuser: FROSTED ACRYLIC		CRI: 93+	Power Factor: >0.9

Mounting Detail

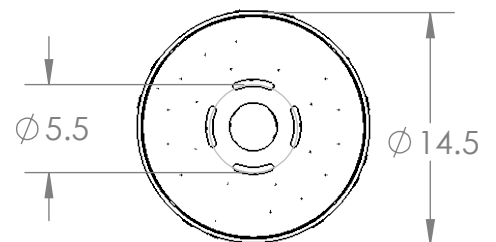

All fixtures created by Hammerton are handcrafted by artisans. Dimensions may vary up to 7/8".

© Copyright 2018. All rights in design, detail or invention of this drawing are reserved as the property of Hammerton. Any imitation or adaptation without written consent is strictly prohibited.