

Collection: PARALLEL GLASS

Product #: LAB0042-01

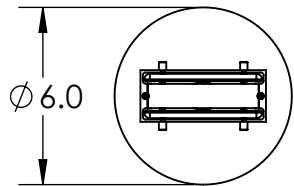
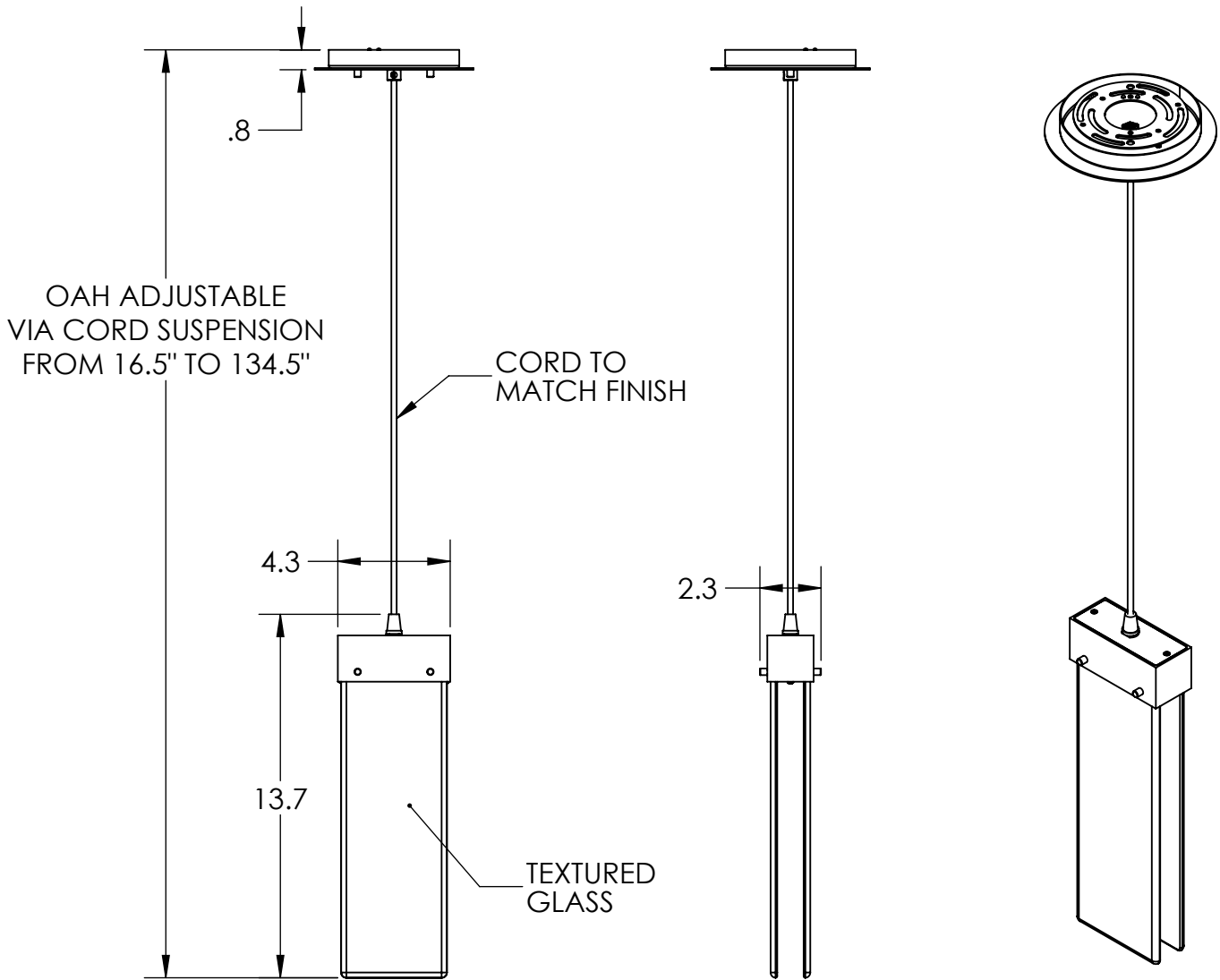

****NOTE****
LED DRIVER TO BE INSTALLED IN J-BOX
MINIMUM SIZE OF J-BOX REQUIRED IS
4" L x 4" W x 1.5" H

Visit hammertonestudio.com for product options and specifications.

8/30/2016 (A)

| | | | |
|--|--------------------------------------|----------------------|--------------|
| Mounting Packet: Y | Weight(lbs.): 5 | Electrical Type: LED | CCT: 2700 K |
| UL Location: DRY | Elec. Qty: 1 | Wattage: 5.2 | Voltage: 120 |
| Finish: SEE WEB SITE FOR OPTIONS | Source Lumens: | Up: N/A | Down: 340 |
| Top Diffuser: CLOSED | Forward/Reverse Phase Dimmable To 1% | | |
| Bottom Diffuser: FROSTED GLASS | CRI: 90+ | Power Factor: >0.9 | |
| All fixtures created by Hammerton are handcrafted by artisans. Dimensions may vary up to 7/8". | | | |
| © Copyright 2016. All rights in design, detail or invention of this drawing are reserved as the property of Hammerton. Any imitation or adaptation without written consent is strictly prohibited. | | | |
| Hammerton Inc. 217 Wright Brothers Dr. Salt Lake City, UT 84116 (801)973-8095 | | | |

Mounting Detail

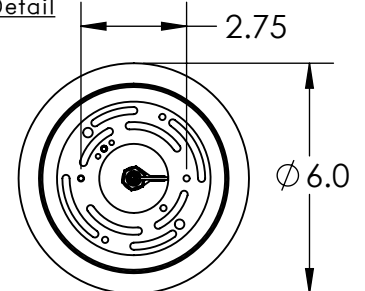

MOUNTS DIRECTLY TO J-BOX