

Collection: PARALLEL GLASS

Product #: CHB0042-11

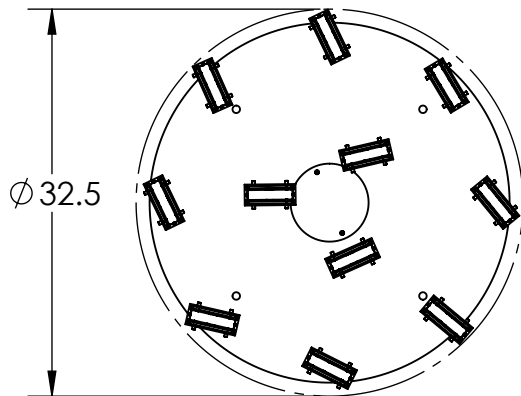
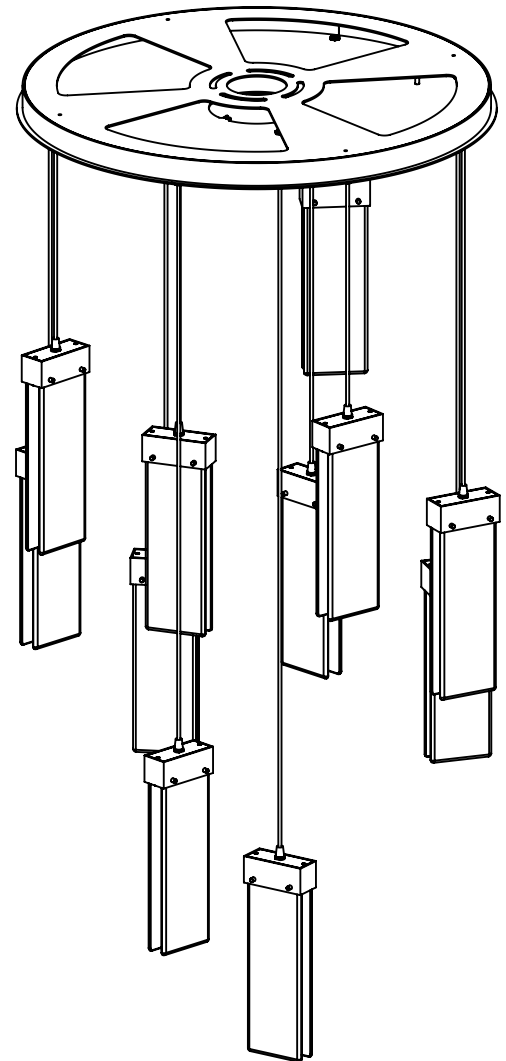
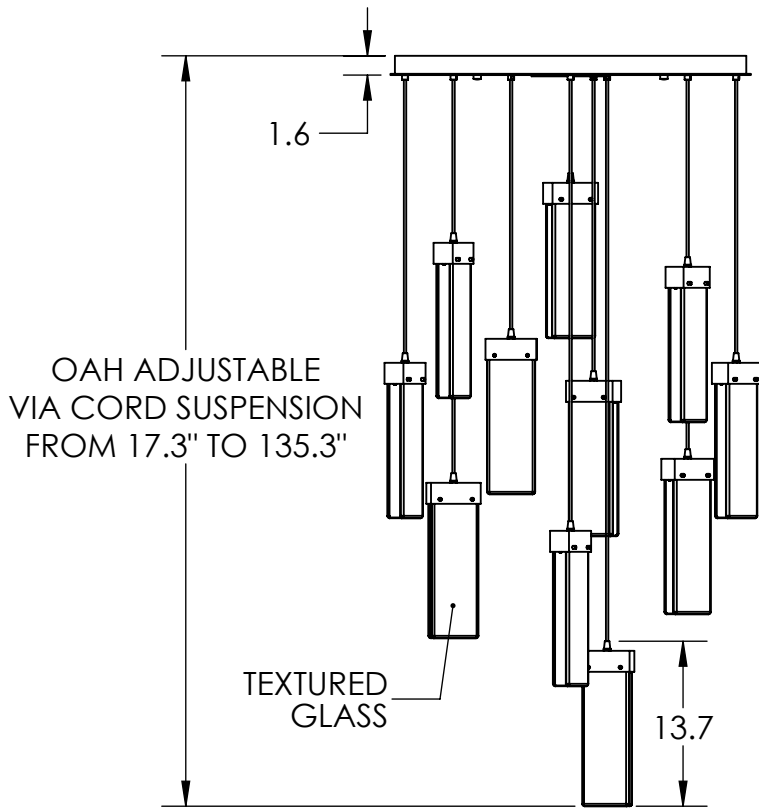

Visit [hammertonstudio.com](http://hammertonstudio.com) for product options and specifications.

8/30/2016 (A)

Mounting Packet: R	Weight(lbs.): 75	Electrical Type: LED	CCT: 2700 K
UL Location: DRY	Elec. Qty: 11	Wattage: 57	Voltage: 120
Finish: SEE WEB SITE FOR OPTIONS	Source Lumens: Up: N/A	Down: 3765	
Top Diffuser: CLOSED	Forward/Reverse Phase Dimmable To 1%		
Bottom Diffuser: FROSTED GLASS	CRI: 90+	Power Factor: >0.9	
All fixtures created by Hammerton are handcrafted by artisans. Dimensions may vary up to 7/8".			
© Copyright 2016. All rights in design, detail or invention of this drawing are reserved as the property of Hammerton. Any imitation or adaptation without written consent is strictly prohibited.			
Hammerton Inc. 217 Wright Brothers Dr. Salt Lake City, UT 84116 (801)973-8095			

Mounting Detail

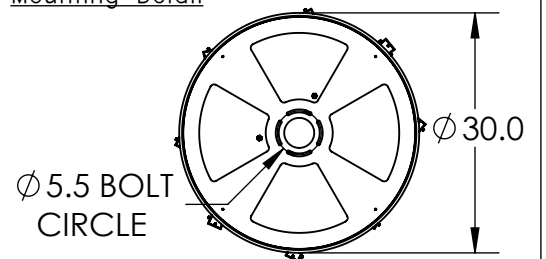

MOUNTS TO BUILDING STRUCTURE