

# Halsey Taylor Owners Manual

*OVL™ Fountains with Dual-Stream Bubbler™  
and HydroBoost™ Bottle Filler*



HTHB-OVLSEBP-I



HTHBWF-OVLSEBP-I

## INSTALLER



### CAUTION:

Review these instructions before beginning installation. Be sure that installation conforms to all plumbing, electrical and other applicable codes.



### WARNING:

When installation is complete, ensure these instructions are left in the plastic bag provided inside the installed unit for future reference.



### WARNING:

Service to be performed by authorized service personnel only.

NOTE: It is common practice to ground electrical hardware such as telephones, computers and other devices to available water lines. This can, however, cause electrical feedback in the plumbing circuit, which results in an “electrolysis” effect occurring in the fountain. This may result in water which has a metallic taste to it or has a noticeable increase in the metallic content of the water.

When inspecting plumbing circuit, remember the line may be grounded some distance from the installation, and may occur outside the building or area in which the unit is being installed.

This condition can be avoided (in most cases) by using recommended materials during installation. Any drain fittings provided by the installer should be made of **plastic** which will electronically isolate the fountain from the remainder of the building’s plumbing circuits.

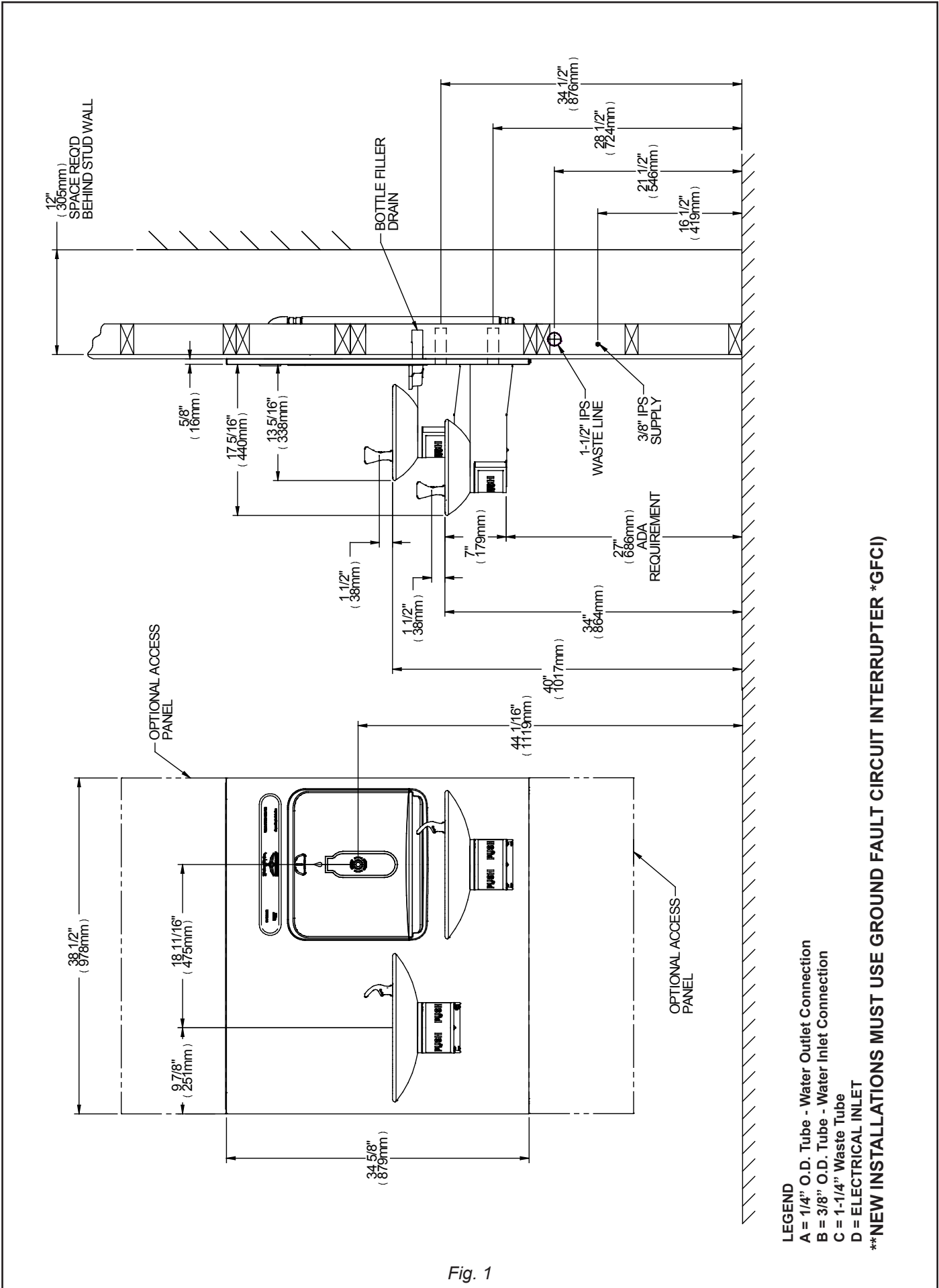

**LEGEND**

- A = 1/4" O.D. Tube - Water Outlet Connection
- B = 3/8" O.D. Tube - Water Inlet Connection
- C = 1-1/4" Waste Tube
- D = ELECTRICAL INLET

**\*\*NEW INSTALLATIONS MUST USE GROUND FAULT CIRCUIT INTERRUPTER \*GFCI)**

Fig. 1

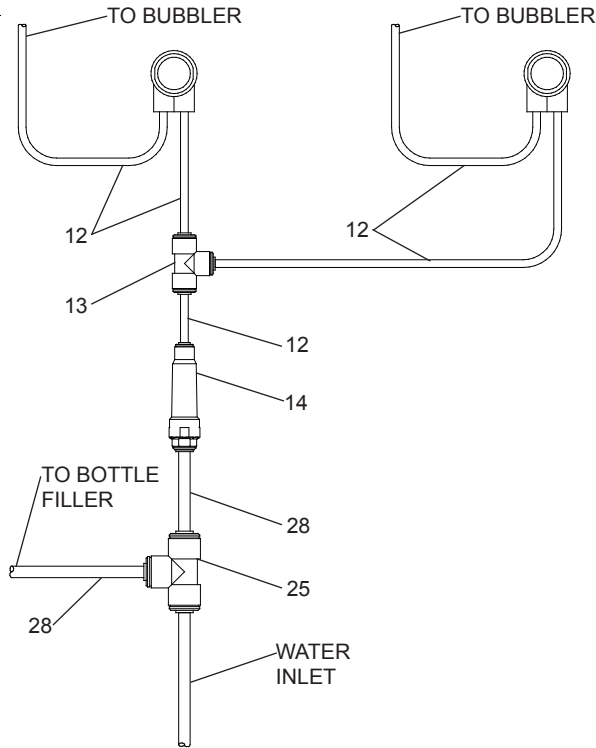

Figure 2 - HTHB-OVLSEBP-I Tube Routing

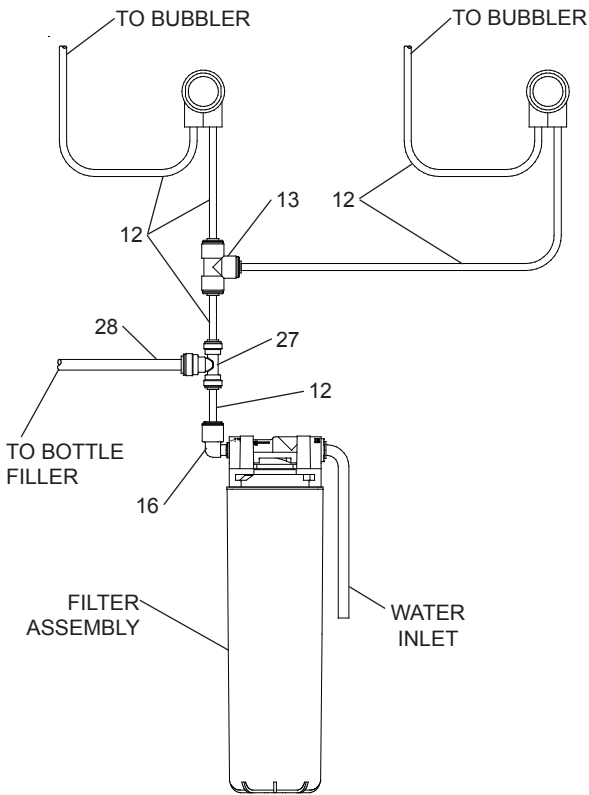

Figure 3 - HTHBWF-OVLSEBP-I Tube Routing

REQUIRED TOOLS AND MATERIALS

These tables show special tools and/or additional materials (not provided) which are necessary to complete installation of these units:

Special Tools		
Item	Description	Quantity
	NONE	

Additional Materials Not Included		
Item	Description	Quantity
1	Unplated copper inlet pipe	1
2	Service Stop/Shut-off Valve	1
3	90° 1-1/4" Drain Line	1
4	1-1/4" Tee Drain Line	1

1. **Make** water supply connections (Fig 13). Install a shut-off valve and union connection to building water supply (valve and union not provided). Turn on water supply and flush the line thoroughly.

**Caution:** DO NOT SOLDER tubes inserted into the strainer or filter head as damage to the o-rings may result.

2. **Install** mounting frame (instructions supplied with mounting frame).
3. **(For HTHBWF-HRSEBP-I)** Install the filter head to the bracket, then install filter bracket on mounting frame (Fig 12), plumb from the filter outlet using the 1/4" elbow, poly tubing and 1/4 x 1/4 x 3/8" tee, install filter.
- 3a. **(For HTHB-HRSEBP-I)** Install 3/8" tee, poly tubing and strainer per (Fig 2).
4. **Install** 1/4 x 1/4 x 3/8 tee on building water supply tube. Install supplied 4" poly tubing and armaflex to the outlet of the previously installed tee. Connect supplied 1/4 x 1/4 x 1/4 tee to the 4" poly tubing. With the back panel standing close to the frame, connect 3/8" poly tube to the bottle filler.
5. **Hang** main panel on mounting frame hanger. Make sure the power cord, reset switch wire & poly tube do not get pinched between the panel & mounting frame. Ensure the panel engages at the top. Align fountain holes with mounting frame holes.
6. **Remove** protective coating from main panel.
7. **Install** fountains with (8) 5/16-18 HHMS (provided) (Fig 5). Connect the 1/4" water lines from each fountain to the remaining openings on the tee at the remote chiller (cut lines to fit as needed).

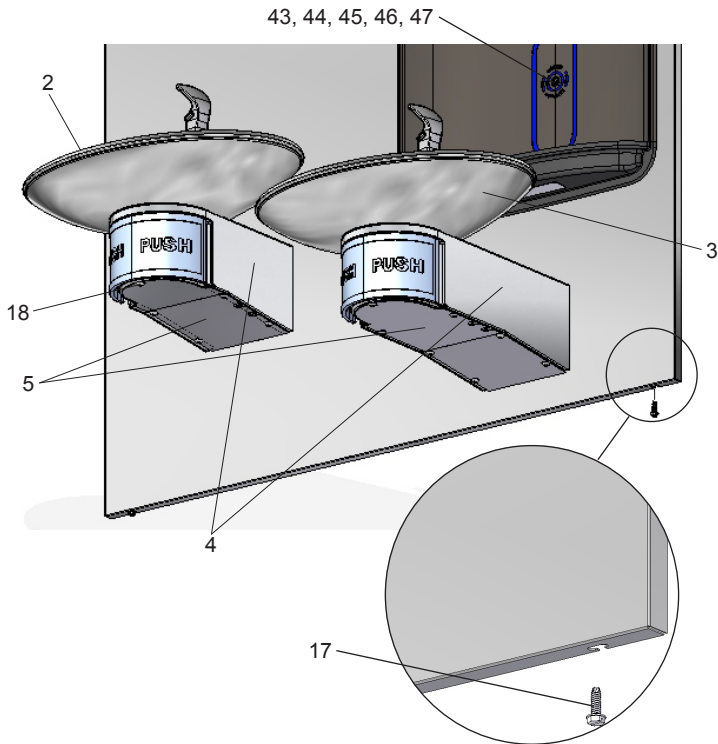

Figure 4 - Upper Panel Installation

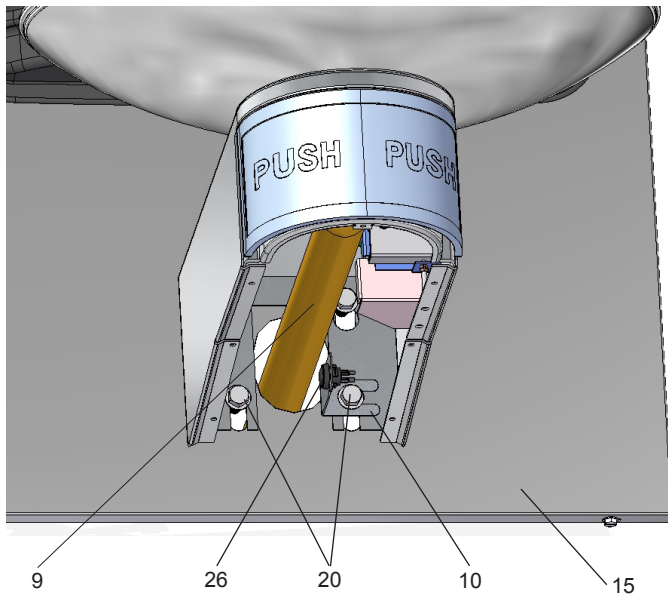

Figure 5 - Fountain Installation

8. **Install** reset switch and mating bracket on lower fountain (lower right bolt) for bottle filler (Fig 5). Connect the switch wire to the extension wire on the back of the bottle filler. Wrap up the excess cord.
9. **Attach** waste tubes (1-1/4" O.D.) to 1-1/4" O.D. slip trap. Trap on the bottle filler side must be 1-1/2" O.D. (provided by others).
10. **Make** final water supply connections.
11. **These** products are designed to operate on 20-105 PSIG supply line pressure. If inlet pressure is above 105 PSIG, a pressure regulator must be installed in the supply line. (**Caution:** Any damage caused by connecting these products to a supply line with pressure lower than 20 PSIG or higher than 105 PSIG IS NOT covered under warranty.)
12. **Make** electrical connections to the bottle filler and remote chiller. The LCD Bottle counter should illuminate.
13. **Verify** proper dispensing from the bottle filler by placing a cup, hand or any opaque object in front of sensor area and verify water dispenses. **Note:** the first initial dispenses might have air in the line which may cause a sputter. This will be eliminated once all air is purged from the line. A steady stream of water assures all air is removed. The sensor has a 20 second maximum ON time. It may be necessary to step away from the beam a few times to purge all air. Check for leaks.
14. **Check** stream height from bubbler. Stream height is factory set at 35 PSI. If supply pressure varies greatly from this, remove push arm (Item 7 - Figure 8) and adjust the screw on the regulator (Item 19 - Figure 7). To remove push button, remove bottom plate (Item 8). Clockwise adjustment will raise stream height and counterclockwise movement will lower stream height. For best adjustment stream should hit basin approximately 6-1/2" from the bubbler. Reassemble the push bar (Fig 8).
15. **Install** the cover plates.
16. **Optional:** Mount optional panels. Install bracket per rough-in, slide tongue of panel under edge of already installed panel. Tighten screws.

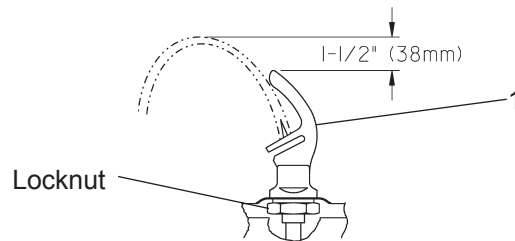
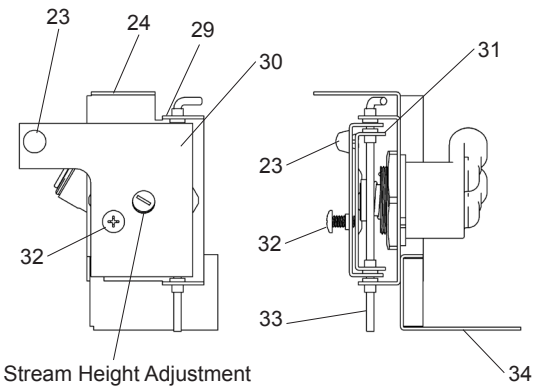
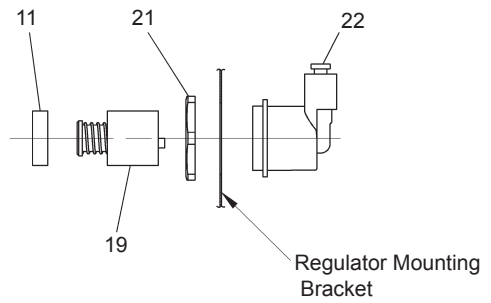

Figure 6 - Bubbler Detail

**NOTE:**  
When installing replacement bubbler and pedestal (Fig 6), tighten locknut only to hold parts snug in position. **Do Not overtighten.**



**Figure 7**  
**Regulator Mounting Mechanism**



**Figure 9**  
**Regulator Assembly**

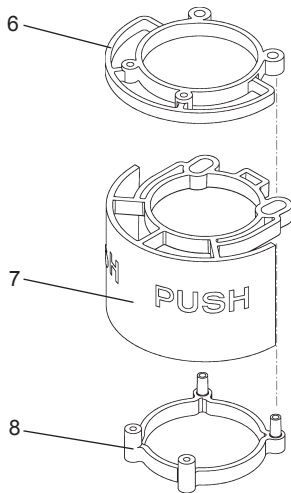

**Figure 8 - Push Bar Mechanism**

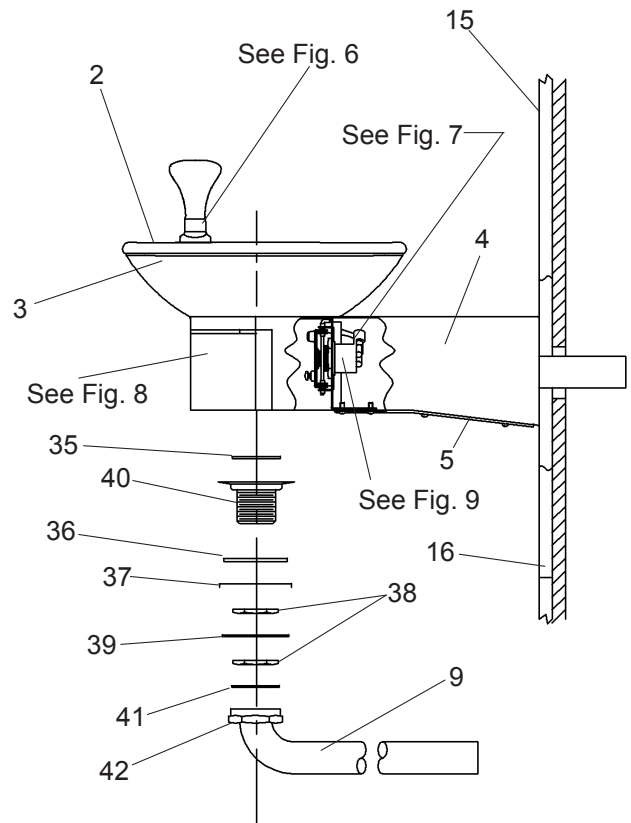

**Figure 10 - Drain Assembly**

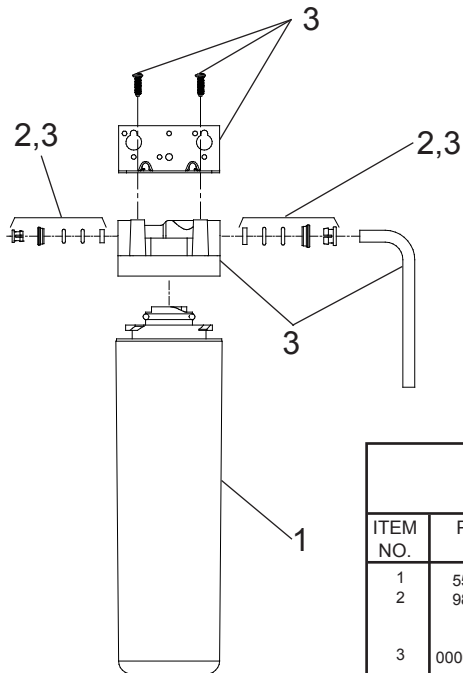

**FIG. 11**

FILTER PARTS LIST (See Fig. 11)			LISTA DE PIEZAS DEL FILTRO (Vea la Fig. 11)	LISTE DES PIÈCES DU FILTRE (Voir Fig. 11)
ITEM NO.	PART NO.	DESCRIPTION	DESCRIPCIÓN	DESCRIPTION
1	55898C	Filter Assy-3000 Gal.	Ensamblado del Filtro-3000 Galón	Ens. filtre-3000 Gallon
2	98926C	Kit-Filter Head Fittings, includes John Guest 3/8" elbow fitting	Kit Filtro cabeza guarniciones, incluye acoplador acodado de John Guest 3/8"	Accessoires de tête, en kit-filtre inclut John Guest raccord en coude 3/8 "
3	0000000929	Assy-Filter & Bracket includes Fitr Head/Mtg Bkt/John Guest Fittings/Screws	Montaje del filtro & soporte incluye filtro cabeza/soporte/John Guest guarniciones/tornillos de montaje	Assy-filtre & Support inclut filtre/montage Support/John Guest/vis à tête

## **BF11 PROGRAM** **SETTING THE CONTROL BOARD**

### **VERIFY CONTROL BOARD SOFTWARE**

- 1) To verify the software program of the control board the unit will need to be shut down and restarted. The chiller (if present) does not need to be shut down and restarted.
- 2) The units lower panel must be open to access the power cord and wall outlet.
- 3) Shut down the unit by unplugging the power cord from the wall outlet.
- 4) Restart the unit by plugging the power cord back into the wall outlet.
- 5) Upon start up, the bottle count display will show the software designation of BF11.
- 6) Reference the BF11 instructions for setting the control board.

### **ACCESSING THE PROGRAMMING BUTTON**

- 1) To access the program button, remove #10-24 screws, remove bottom cover on lower fountain arm (Fig 5). Reset button is located on mounting bracket.

### **RESET THE FILTER MONITOR**

- 1) Instructions apply to filtered units only.
- 2) Depress the program button for approximately 2 seconds until the display changes then release. The display will change and scroll through two messages:  
"RST FLTR" – Reset Filter Monitor  
"SETTINGS" – System Settings Sub Menu  
If the program button is not pushed again the display will scroll through the two messages above for three cycles and then default back to bottle count and be back in run mode.
- 3) When the display changes to "RST FLTR", depress the button again. The display will change to show "FLTR =". Depress the button again and the display will show "FLTR =0"
- 4) The Green LED should be illuminated indicating that the visual filter monitor has been reset.

### **SETTING RANGE OF THE IR SENSOR**

- 1) Depress the program button for approximately 2 seconds until the display changes then release. The display will change and scroll through two messages:  
"RST FLTR" – Reset Filter Status LED  
"SETTINGS" – System Settings Sub Menu  
If the program button is not pushed again the display will scroll through the two messages above for three cycles and then default back to bottle count and be back in run mode.
- 2) When the display changes to "SETTINGS", depress the button again. The display will change to show  
"RNG SET" - Range set for IR sensor.  
"UNIT TYP" - Type of unit (REFRIG or NON-RFRG)  
"FLT SIZE" - Select filter capacity  
"RST BCNT" - Reset bottle count
- 3) When display shows "RNG SET" push program button once the display will show current value (can be 1 – 10) e.g. "RNG = 3".
- 4) Once display shows current value push the program button to scroll through value of 1 – 10. Select the desired range setting.
- 5) Once range is selected allow approximately 4 seconds to pass and then the display will go back to bottle counter and be in run mode.
- 6) Test bottle filler by placing bottle or hand in front of sensor to make sure water is dispensed.

### **SETTING UNIT TYPE**

- 1) Depress the program button for approximately 2 seconds until the display changes then release. The display will change and scroll through two messages:  
"RST FLTR" – Reset Filter Status LED  
"SETTINGS" – System Settings Sub Menu  
If the program button is not pushed again the display will scroll through the two messages above for three cycles and then default back to bottle count and be back in run mode.

Continued from below:

- 2) When the display changes to "SETTINGS", depress the button again.  
The display will change to show  
"RNG SET" - Range set for IR sensor.  
"UNIT TYP" - Type of unit (REFRIG or NON-RFRG)  
"FLT SIZE" - Select filter capacity  
"RST BCNT" - Reset bottle count
- 3) When display shows "UNIT TYPE" push program button once the display will show current value. Can be REFRIG or NON-RFRG
- 4) Push button once to change value. Once value is selected the display will show the new value. (Can be REFRIG or NON-RFRG)  
"REFRIG" - stands for refrigerated product. In this setting the flow rate is estimated at 1.0 gallon per minute.  
"NON-RFRG" - stands for nonrefrigerated product. In this setting the flow rate is estimated at 1.5 gallons per minute. Both "REFRIG" and "NON-RFRG" simulate 1 bottle equal to 20 oz.
- 5) Allow approximately 4 seconds to pass and the display will return to bottle counter and be in run mode.

### **RESETTING BOTTLE COUNT**

- 1) Depress the program button for approximately 2 seconds until the display changes then release. The display will change and scroll through two messages:  
"RST FLTR" – Reset Filter Status LED  
"SETTINGS" – System Settings Sub Menu  
If the program button is not pushed again the display will scroll through the two messages above for three cycles and then default back to bottle count and be back in run mode.
- 2) When the display changes to "SETTINGS", depress the button again.  
The display will change to show:  
"RNG SET" - Range set for IR sensor.  
"UNIT TYP" - Type of unit (REFRIG or NON-RFRG)  
"FLT SIZE" - Select filter capacity  
"RST BCNT" - Reset bottle count  
If the button is not pushed again the display will scroll through the four messages above for three cycles and return to run mode.
- 3) When display shows "RST BCNT" push program button once the display will show current value e.g. "0033183".
- 4) Once display shows current value push the program button once more to reset back to 0. The display will show BTLCT = 0 for approximately 2 seconds and then return to run mode showing 00000000 bottles.
- 5) Testing the bottle counter:  
REFRIG units: Place bottle or hand in front of sensor for 9.4 seconds to see bottle counter count 00000001,  
(This is based on filling a 20 oz. bottle).  
NON-RFRG units: Place bottle or hand in front of sensor for 6.25 seconds to see bottle counter count 00000001,  
(This is based on filling a 20 oz bottle).

### **SETTING FILTER CAPACITY**

- 1) Depress the program button for approximately 2 seconds until the display changes then release. The display will change and scroll through two messages:  
"RST FLTR" – Reset Filter Status LED  
"SETTINGS" – System Settings Sub Menu  
If the program button is not pushed again the display will scroll through the two messages above for three cycles and then default back to bottle count and be back in run mode.
- 2) When the display changes to "SETTINGS", depress the button again.  
The display will change to show:  
"RNG SET" - Range set for IR sensor.  
"UNIT TYP" - Type of unit (REFRIG or NON-RFRG)  
"FLT SIZE" - Select filter capacity  
"RST BCNT" - Reset bottle count  
If the button is not pushed again the display will scroll through the four messages above for three cycles and return to run mode.
- 3) When display shows "FLT SIZE" push program button once. The display will show current value. Can be 3000GAL or 6000GAL.
- 4) Push program button again to display the desired "FLT SIZE".
- 5) Allow approximately 4 seconds to pass and the display will return to bottle counter and be in run mode.



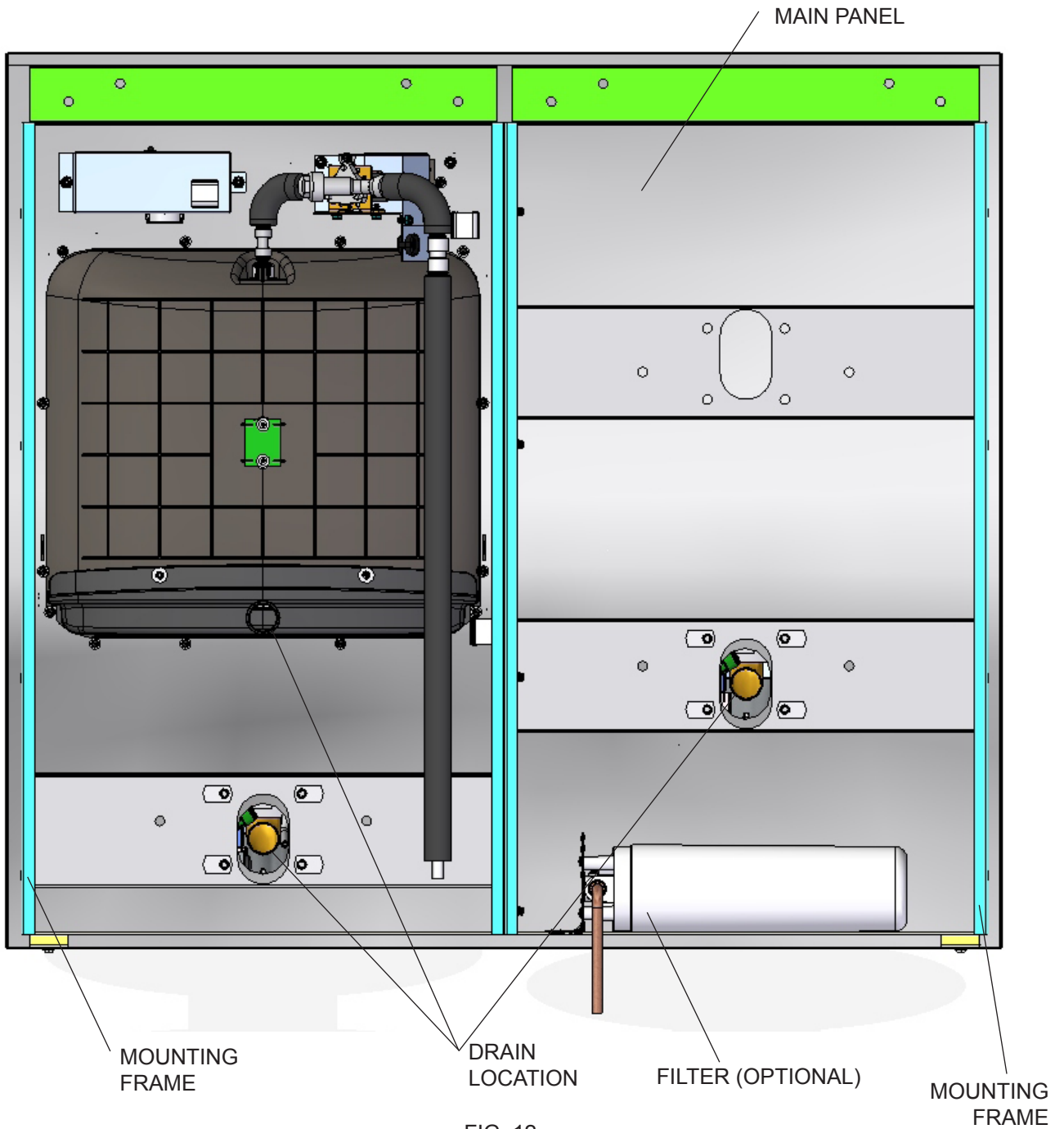

FIG. 12

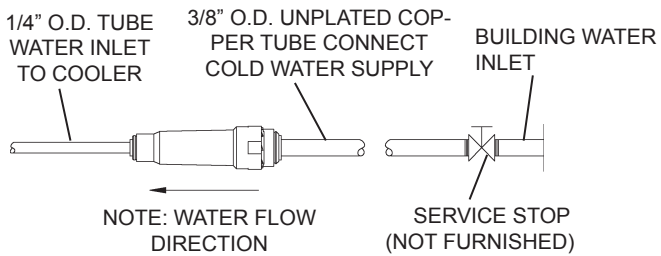

Figure 13 – Water Supply Connections

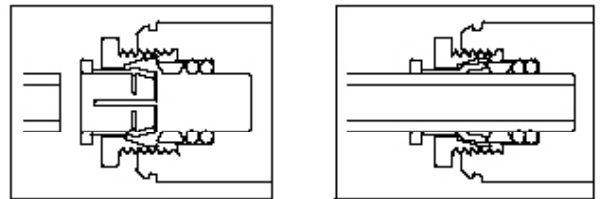

Figure 14

PARTS LIST		
ITEM NO	PART NO.	DESCRIPTION
1	51546C	Bubbler
2	27006C	Basin
3	27000C	Lower Shell
4	27002C	Fountain Arm (Long)
	27004C	Fountain Arm (Short)
5	26988C	Bottom Cover (Long)
	26990C	Bottom Cover (Short)
6	55840C	Top Plate Actuator
7	55836C	Push Arm Actuator
8	55839C	Bottom Plate Actuator
9	45683C	Drain Tube (Long)
	45682C	Drain Tube (Short)
10	0000001153	Reset Switch Bracket
11	15005C	Retaining Nut
12	56092C	Poly Tubing (Cut To Length)
13	70682C	Tee - 1/4
14	55996C	Strainer (Provided with Chiller)
15	0000000981	Back Panel RH ADA
16	70817C	Fitting - Elbow 1/4 x 1/4
17	111008343890	Screw - #10-24 x .62 HHSM
18	112627543890	Screw-#10-24X.50 PHTC
19	61314C	Regulator
20	75560C	Screw - 5/16-18 x 1.00 HHMS
21	40045C	Hex Nut
22	50986C	Regulator Holder
23	51667C	Bumper - Regulator Valve Assy
24	28328C	Regulator Mounting Bracket
25	70852C	Tee - 3/8
26	36301C	Reset Switch
27	0000001144	Tee - 1/4 x 1/4 x 3/8
28	56372C	Poly Tubing 3/8" (Cut To Length)
29	50198C	Snap Bushing
30	28327C	Arm - Regulator Activating
31	28326C	Arm - Regulator Adjustment
32	70856C	Screw - #10-24 x .38 PHMS
33	70854C	Rod - Pivot
34	27008C	Reaction Bracket
35	160270508640	Strainer Plate
36	101570540560	Drain Gasket
37	51575C	Packing Ring
38	110346220550	Drain Nut
39	101637451550	Friction Ring
40	161637308640	Drain Plug
41	100023340560	Waste Tube Gasket
42	161570808550	Slip Nut

BOTTLE FILLER REPLACEMENT PART KITS		
ITEM NO.	PART NO.	DESCRIPTION
43	98543C	Kit - Electrical Package
44	98544C	Kit - EE Sensor
45	98545C	Kit - Solenoid Valve Replacement
46	98546C	Kit - Aerator Replacement
47	98549C	Kit - Hardware & Waterway Parts

### Installation Package

The components for installation are packed in two separate boxes, regardless of the type of unit being installed. The boxes contain the following:

**Box No. 1: Wall Frame(s)**

**Box No. 2: Fountain(s), Arm(s) and Panels**

Additional materials, as noted in the Parts List, are also shipped in these boxes.

### TROUBLESHOOTING & MAINTENANCE

**Orifice Assembly:** Mineral deposits on orifice can cause water flow to spurt or not regulate. Mineral deposits may be removed from the orifice by poking with a small round file not over 1/8" diameter, or using a small diameter wire.



**CAUTION: DO NOT** file or cut orifice material

**Stream Regulator:** If orifice is clean, regulate flow as in Step 14 of the installation instructions. If replacement is necessary, see parts list for correct regulator part number.

**Actuation of Quick Connect Water Fittings:** Cooler is provided with lead-free connectors which utilize an o-ring water seal. To remove tubing from the fitting, relieve water pressure, push in on the gray collar while pulling on the tubing. (See Figure 15) To insert tubing, push tube straight into fitting until it reaches a positive stop (approximately 3/4").

### OPERATION OF QUICK CONNECT FITTINGS

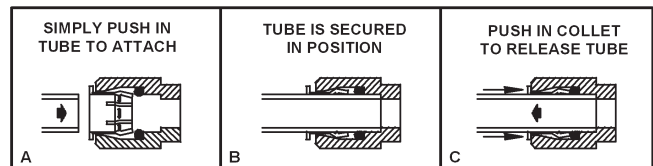

PUSHING TUBE IN BEFORE PULLING IT OUT HELPS TO RELEASE TUBE

Figure 15 – Quick Connect Fittings