

**PRODUCT SPECIFICATIONS**

Halsey Taylor Outdoor Sierra Stone Fountain, Pedestal Non-Filtered Non-Refrigerated Freeze Resistant. Features shall include Freeze Resistant. Furnished with Vandal Resistant bubbler. Mechanical Front Bubbler Button activation. Product shall be Floor Mount/Freestanding, for Outdoor applications, serving 1 station(s). Unit shall be lead-free design which is certified to NSF/ANSI 61 & 372 (lead free) and meets Federal and State low-lead requirements.



<b>Special Features:</b>	Freeze Resistant
<b>Finish:</b>	Stone Aggregate
<b>Power:</b>	No Electrical Required
<b>Bubbler Style:</b>	Vandal Resistant
<b>Activation by:</b>	Mechanical Front Bubbler Button
<b>Mounting Type:</b>	Floor Mount/Freestanding
<b>Chilling Option:</b>	Non-refrigerated
<b>Approx. Shipping Weight:</b>	205 lbs.
<b>Installation Location:</b>	Outdoor
<b>No. of Stations Served:</b>	1

- Mechanically-Activated bubbler continues to supply water in event of service disruptions.
- Freeze Resistant:  
- Depending on specific installation, freeze resistant system is located either below frost line or in temperature controlled space.

AMERICAN PRIDE. A LIFETIME TRADITION. Like your family, the Elkay family has values and traditions that endure. For almost a century, Elkay has been a family-owned and operated company, providing thousands of jobs that support our families and communities.



**Included with Product:** Outdoor Fountain, Freeze Resistant Valve Assembly

**PRODUCT COMPLIANCE**

- ADA & ICC A117.1
- ASME A112.19.3/CSA B45.4
- Buy American Act
- NSF/ANSI 61 & 372 (lead free)



Complies with ADA & ICC A117.1 accessibility requirements when installed according to the requirements outlined in these standards. Installation may require additional components and/or construction features to be fully compliant. Consult the local Authority Having Jurisdiction if necessary.

[Installation Instructions \(PDF\)](#)

**Warranty pertains to drinking water applications only. Non-drinking water applications are not covered under warranty.**

[Warranty \(PDF\)](#)

PART: \_\_\_\_\_ QTY: \_\_\_\_\_

PROJECT: \_\_\_\_\_

CONTACT: \_\_\_\_\_

DATE: \_\_\_\_\_

NOTES: \_\_\_\_\_

APPROVAL: \_\_\_\_\_

*In keeping with our policy of continuing product improvement, Halsey Taylor reserves the right to change product specifications without notice. Please visit Halseytaylor.com for the most current version of Halsey Taylor product specification sheets. This specification describes a Halsey Taylor product with design, quality, and functional benefits to the user. When making a comparison of other producers' offerings, be certain these features are not overlooked.*

### MOUNTING INSTRUCTIONS and PLUMBING INSTRUCTIONS

Site and drainage excavation is required for fountain installation. Refer to owner's manual for site preparation details. Provide solid, well-drained surface to mount pedestal fountain (concrete pad recommended). (4) 1/2" anchor bolts (not included) should be attached firmly to mounting surface in order to secure fountain. Refer to rough-in diagram and be sure to allow an opening for the freeze-resistant valve in the ground as shown in the installation instructions that accompany the fountain. Refer to local codes for any additional requirements.

**NOTE:** Fountain is not furnished with service valve. Assemble fountain to prepared site and mounting pad.

Position pedestal over plumbing and secure base to anchor bolts. Remove access panels and connect supply and water lines. Turn on water supply and check for leaks. Refer to owner's manual for detailed instructions.

**Service stop not included.**

**Operating Pressures: Supply water - 105 psi maximum.**

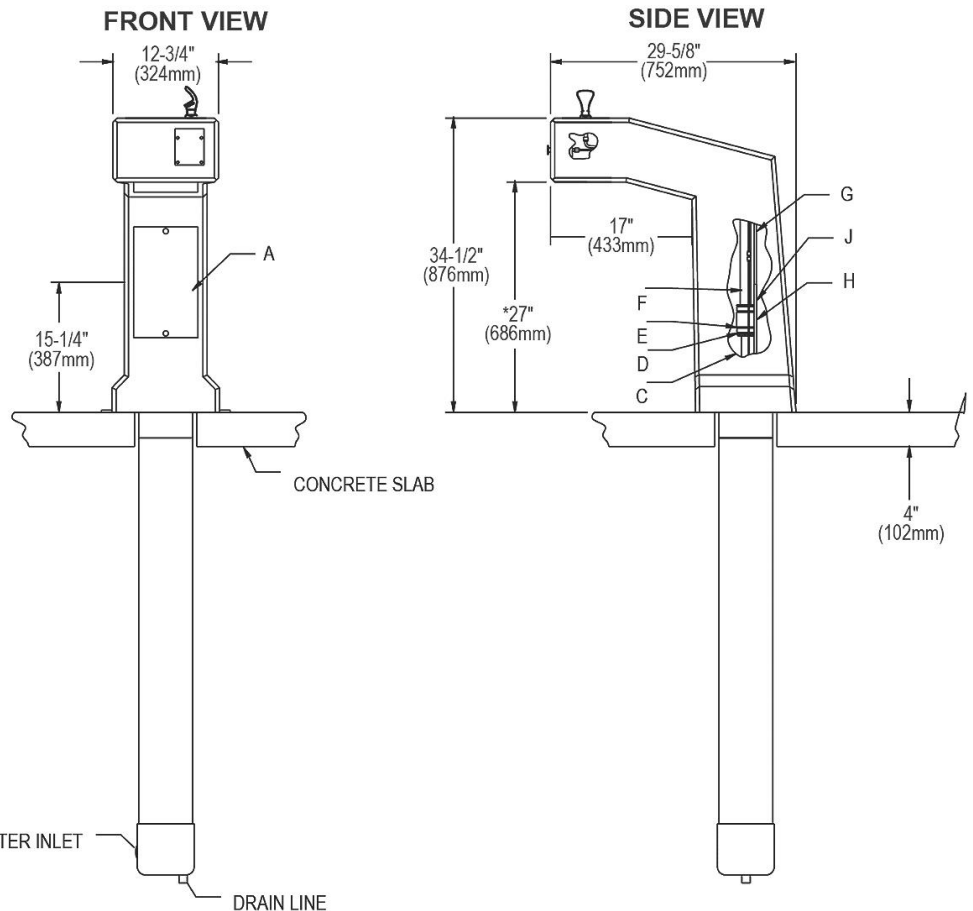
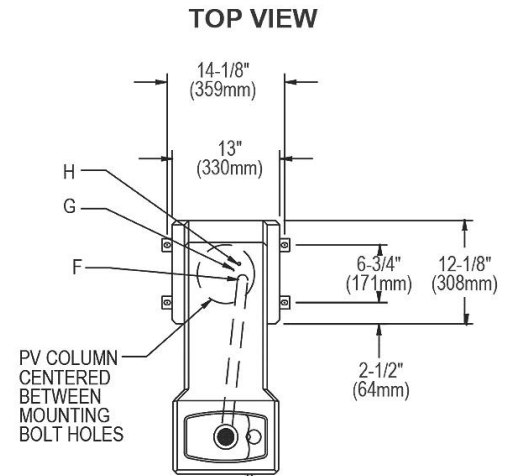

#### LEGEND

- A = Access panel (8" X 10")
- B = Removable bottom cover
- C = 1" PVC drain
- D = Pressure fitting 1-1/4" x 3/4"
- E = Connector 1-1/4" to 1-1/4"
- F = 1-1/4" Drain tube
- G = Air control line
- H = 1/4" Water line
- J = Connector for air control line

\* ADA Requirement

In keeping with our policy of continuing product improvement, Halsey Taylor reserves the right to change product specifications without notice. Please visit [Halseytaylor.com](http://Halseytaylor.com) for the most current version of Halsey Taylor product specification sheets. This specification describes a Halsey Taylor product with design, quality, and functional benefits to the user. When making a comparison of other producers' offerings, be certain these features are not overlooked.