

ITEM NO.	QTY.	FILE NAME	DESCRIPTION
1	1	S-LS00519	3951 ADJ SPRING LATCH
2	1	S-LS00505	EXTERIOR ROSE ASSEMBLY
2.9	1	S-LS00494	ROSE
2.10	1	S-LS00493	EXTERIOR FIRE SHIELD
3	1	S-LS00236	STANDARD 1-1/4" X 4-7/8" ASA STRIKE
4	1	S-LS00505	INTERIOR ROSE ASSEMBLY
4.9	1	S-LS00526	INTERIOR FIRE SHIELD
4.11	1	S-LS00494	ROSE
5	1	S-LS00496	ARCHER KEYED / PUSHBUTTON LEVER
6	1	S-LS00496	ARCHER PRIVACY LEVER
7	2	Round Head Screw_AI	CUSTOM 8-32 X 1-1/8" RPHMS
8	2	S-LS00882	#12 X 3/4" FPH COMBO SCREW
9	2	S-LS00882	#8 X 3/4" FPH COMBO SCREW

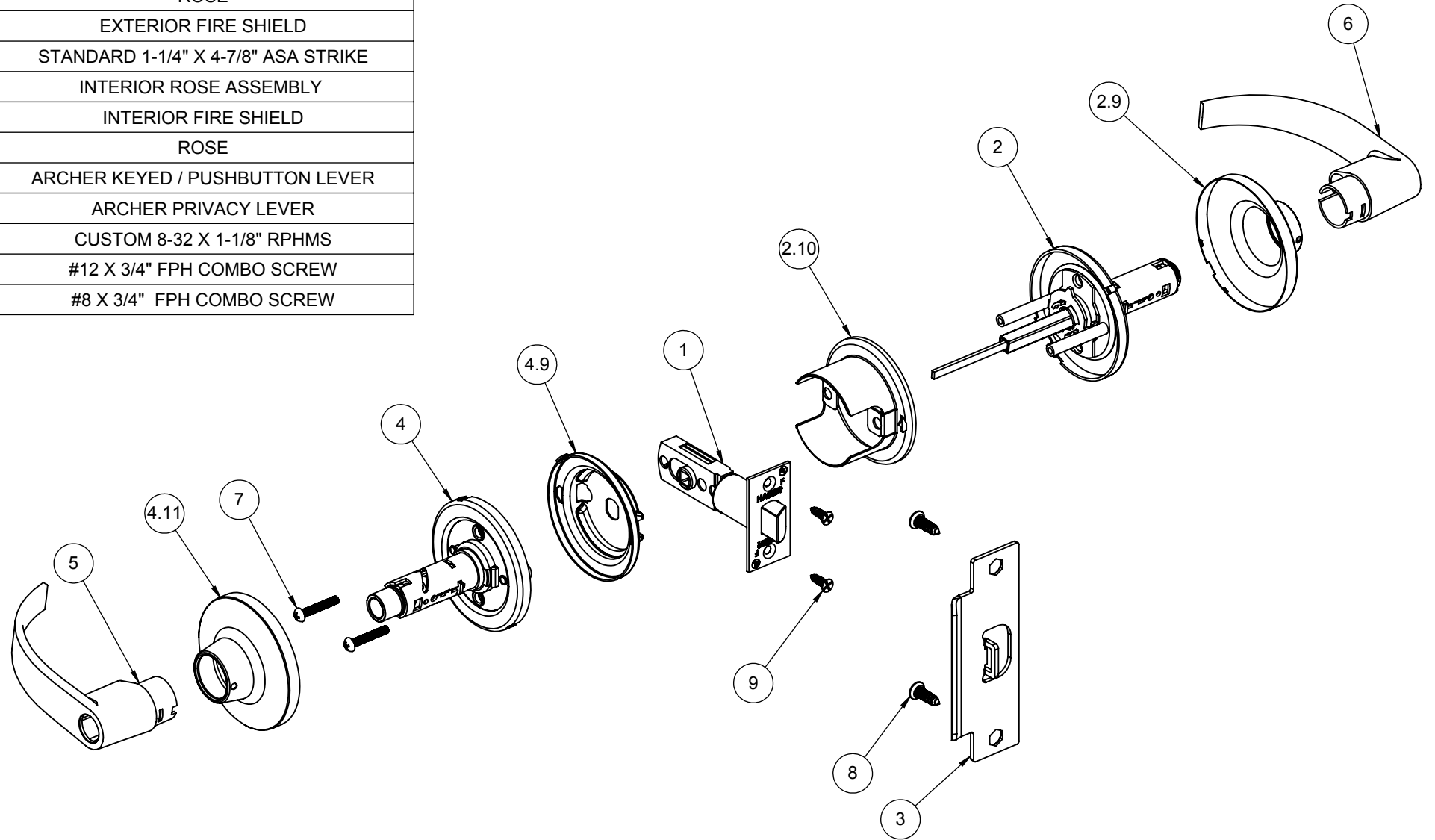

NOTE: ARCHER LEVER SHOWN, OTHERS OPTIONAL



PROPRIETARY & CONFIDENTIAL
 THE INFORMATION CONTAINED
 IN THIS DRAWING IS THE SOLE
 PROPERTY OF HAGER
 COMPANIES. ANY REPRODUCTION
 IN PART OR AS A WHOLE WITHOUT
 THE WRITTEN PERMISSION OF
 HAGER COMPANIES IS PROHIBITED.

HAGER RESERVES
 THE RIGHT TO
 MAKE DESIGN
 CHANGES
 WITHOUT NOTICE.
 CALL HAGER
 ENGINEERING AT
 1-800-325-9995
 FOR THE LATEST
 REVISION DATE
 OF TEMPLATE.

MATERIAL	
FINISH	
DO NOT SCALE DRAWING	

DRAWN	MRJ	8/20/2009
ENG. APPR.	-	-
TOLERANCES:		
FRACTIONAL: ±0.015"		
ANGULAR: MACH: ±1° BEND: ±1°		
TWO PLACE DECIMAL: ±0.01"		
THREE PLACE DECIMAL: ±0.004"		

3640		GRADE 2 - PRIVACY LEVERSET (TUBULAR)	
SIZE	DWG. NO.	REV.	
B	S-LS00871		01
SCALE: 1:12	WEIGHT:	SHEET 1 OF 1	