

For use on doors 1-3/8" to 1-3/4" (35 mm - 45 mm) thick

TOOLS REQUIRED FOR NEW INSTALLATION:

- (1) Phillips Head Screwdriver
- (1) 2-1/8" (54 mm) Hole Saw
- (1) 1" (25.4 mm) Drill Bit
- (1) Chisel

TOOLS REQUIRED FOR REPLACEMENT INSTALLATION:

- (1) Phillips Head Screwdriver

FOR REMODELING OR NEW CONSTRUCTION:

-Follow all steps

FOR REPLACEMENT OF EXISTING LOCK:

-Follow steps 1, 3C, 4C, 5C, 6 through 9 after removal of old lock

FOR CYLINDER REPLACEMENT:

-Follow Step 10

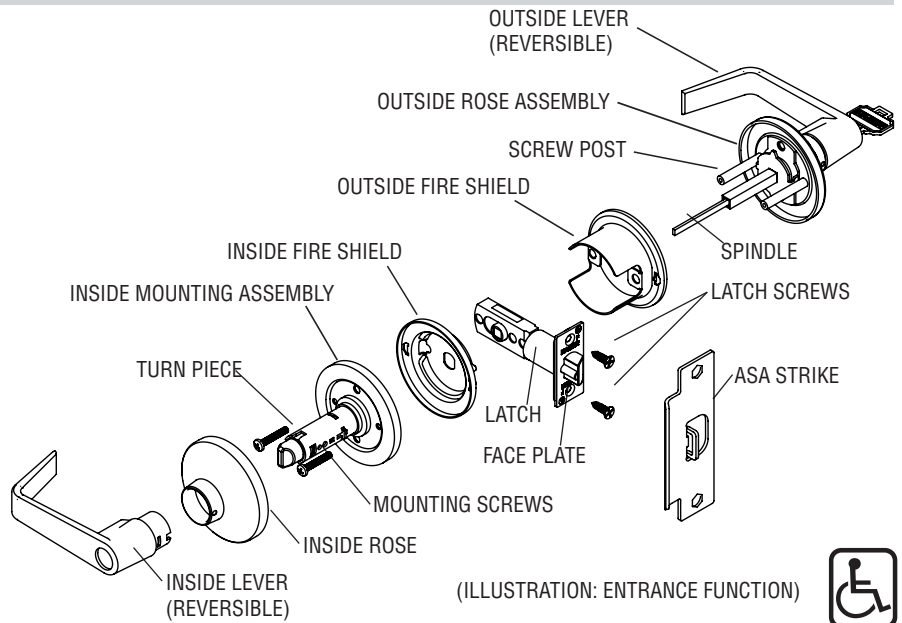

1. LATCH BACKSET ADJUSTMENT

A. If 2-3/4" backset is required, pull spindle cam all the way to the right edge of the adjusting hole.

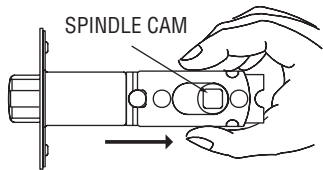

B. Be sure spindle hole is properly aligned. It is important that the spindle hole remains properly aligned throughout the installation.

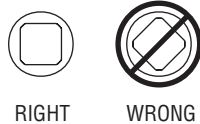

C. The latch is now set for 2-3/4" backset.

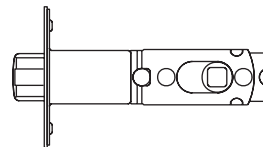

D. To reset the latch to 2-3/8" backset, push the spindle cam to the left edge of the adjusting hole.

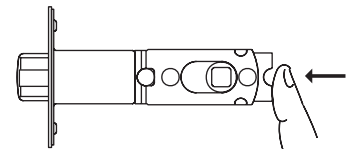

2. MARK DOOR

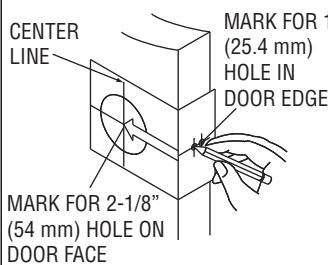

Measure center line of lock; height as desired from finished floor. Select 2-3/8" or 2-3/4" backset, fold and apply template to high side of door bevel and mark center of door edge as indicated on template. Mark center hole on door face through guide on template.

3. DRILL HOLES

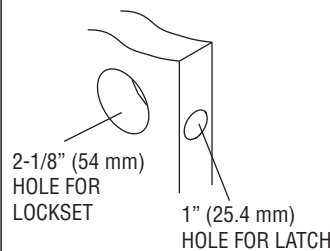

Drill 2-1/8" (54 mm) hole through door face as marked for lockset. (It is recommended that holes be drilled from both sides on wood doors to prevent splitting.) Drill 1" (25.4 mm) hole in center of door edge for latch.

4. INSTALL LATCH

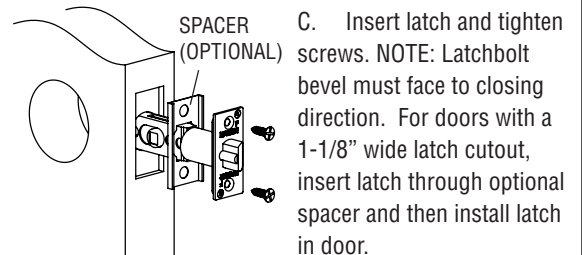
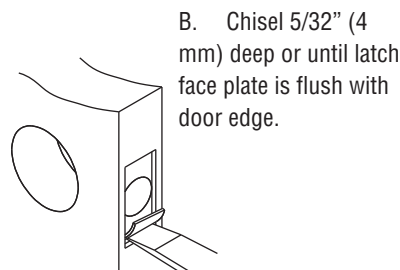
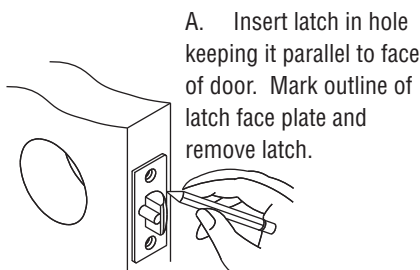

5. INSTALL STRIKE

A. Close door until latchbolt touches jamb. Locate strike in jamb and center line of strike. Open door and extend line to door stop. Measure one half of door thickness plus 1/8" from door stop. Vertically mark center line for strike.

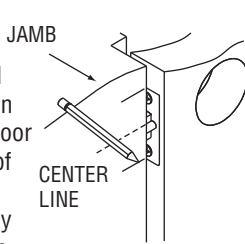

B. Drill two (2) 1-inch (25.4 mm) holes 3/4" (19 mm) deep in door jamb 5/16" (8 mm) above and 5/16" (8 mm) below horizontal center line. CAUTION: To ensure proper lockset function, hole in jamb must be drilled a full 3/4" (19 mm) deep.

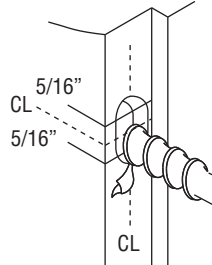

C. Cut out jamb mortise for strike 3/32" (2.4 mm) deep or until strike is flush with jamb. Tighten screws. Latch stops against strike, as illustrated.



6. REMOVE INSIDE MOUNTING ASSEMBLY

Use catch release tool (provided) to depress inside lever catch through hole of inside trim collar. Pull lever off of inside mounting assembly. Remove inside rose from the mounting assembly.

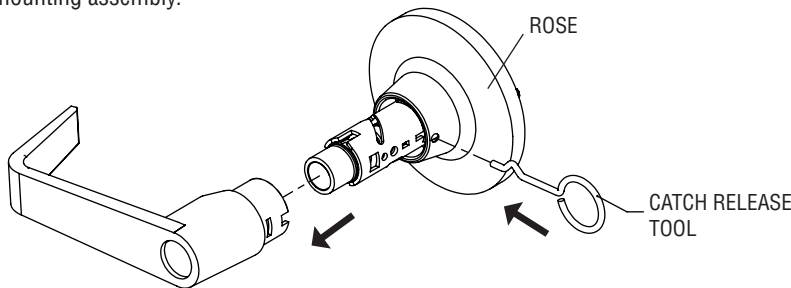

7. INSTALL OUTSIDE LEVER

Place outside lever over the hole in the door face, inserting spindle through latch. Press outside rose assembly flush against door. NOTE: For proper installation, verify outside fire shield is fully seated in the outside rose assembly.

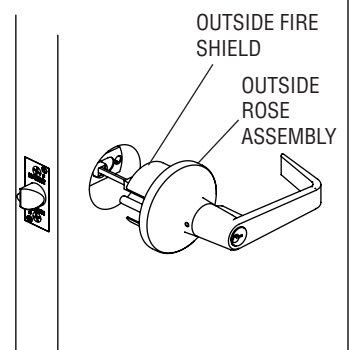

8. INSTALL INTERIOR MOUNTING ASSEMBLY

Insert and fully seat inside fire shield into inside mounting assembly. Align inside mounting assembly with spindle and screw posts. Verify catch release button is pointing in the direction of the lock stile and slide on until flush with face of door. Place mounting screws into holes and tighten securely.

Snap the inside rose onto the mounting assembly (for proper fit, be sure to fit notches in the rose into the recesses on the mounting assembly).

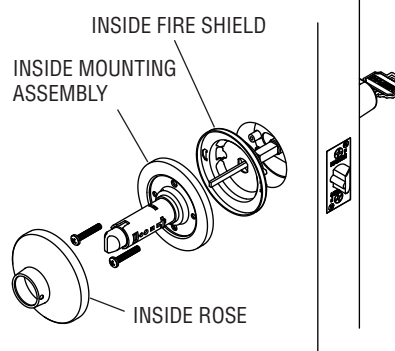

9. INSTALL INSIDE LEVER

Push inside lever all the way until catch clicks into catch slot.

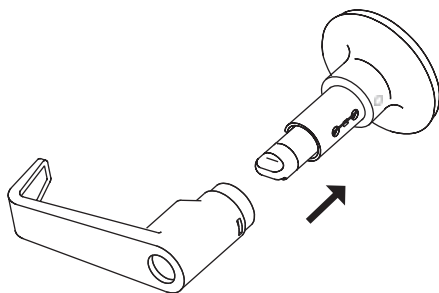

10. INSTALL CYLINDER (SKIP THIS STEP FOR 3610 AND 3640)

A. Turn key clockwise 1/4 turn.

B. Using catch release tool, press the lever catch and pull the lever off.

