

For use on doors 1-3/8" to 1-3/4" (35 mm - 45 mm) thick

TOOLS REQUIRED FOR NEW INSTALLATION:

- (1) Phillips Head Screwdriver
- (1) 2-1/8" (54 mm) Hole Saw
- (1) 1" (25.4 mm) Drill Bit
- (1) Chisel
- (1) Catch-Release Tool (Provided)
- (1) Hex Wrench (Provided)

TOOLS REQUIRED FOR REPLACEMENT INSTALLATION:

- (1) Phillips Head Screwdriver

FOR REMODELING OR NEW CONSTRUCTION:

-Follow all steps

FOR REPLACEMENT OF EXISTING LOCK:

-Follow steps 3C, 4C, 5 through 9 after removal of old lock

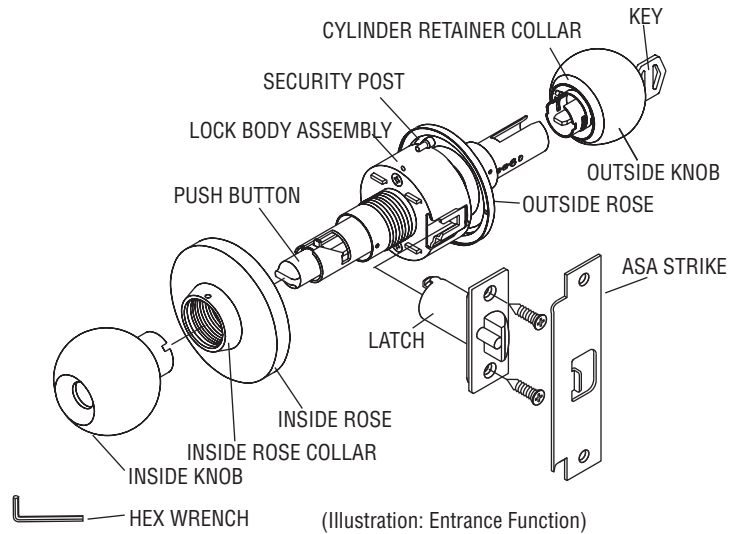

(Illustration: Entrance Function)

1. MARK DOOR

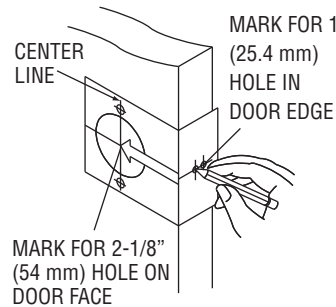

MARK FOR 1" (25.4 mm) HOLE IN DOOR EDGE

Measure center line of lock; height as desired from finished floor. Select 2-3/4" or optional 2-3/8" backset, fold and apply template to high side of door bevel and mark center of door edge as indicated on template. Mark center hole and security post holes on exterior door face through guide on template.

NOTE: Security post holes only required on exterior face of door.

2. DRILL HOLES

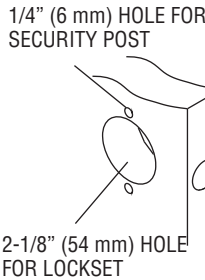

1/4" (6 mm) HOLE FOR SECURITY POST

2-1/8" (54 mm) HOLE FOR LOCKSET

1" (25.4 mm) HOLE FOR LATCH

Drill 2-1/8" (54 mm) hole through door face as marked for lockset. (It is recommended that holes be drilled from both sides on wood doors to prevent splitting.) Drill 1/4" (6 mm) holes 1/4" deep in exterior face of door for security posts. Drill 1" (25.4 mm) hole in center of door edge for latch.

3. INSTALL LATCH

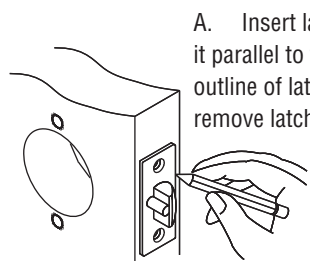

A. Insert latch in hole keeping it parallel to face of door. Mark outline of latch face plate and remove latch.

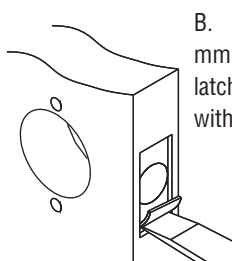

B. Chisel 5/32" (4 mm) deep or until latch face plate is flush with door edge.

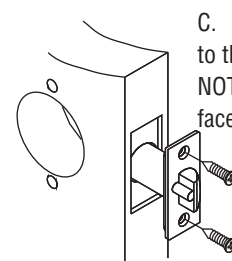

C. Insert latch and tighten to the door using #8 screws. NOTE: Latchbolt bevel must face to closing direction.

4. INSTALL STRIKE

A. Close door until latchbolt touches jamb. Locate strike in jamb and center line of strike. Open door and extend line to door stop. Measure one half of door thickness plus 1/8" from door stop. Vertically mark center line for strike.

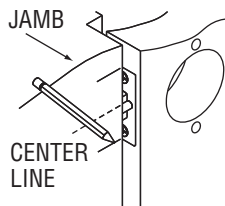

B. Drill two (2) 1" (25.4 mm) holes 3/4" (19 mm) deep in door jamb 5/16" (8 mm) below horizontal center line. CAUTION: To ensure proper lockset function, hole in jamb must be drilled a full 3/4" (19 mm) deep.

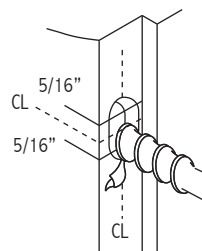

C. Cut out jamb mortise for strike 3/32" (2.4 mm) deep or until strike is flush with jamb. Tighten to the frame using #12 screws. Latch stops against strike, as illustrated.

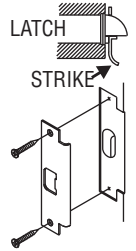

5. REMOVE INSIDE TRIM

A. Use catch release tool to depress inside knob catch in hole of inside sleeve collar and slide knob off spindle.

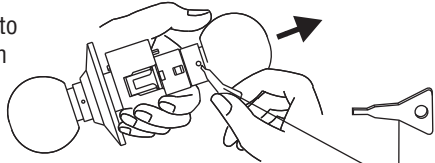

CATCH RELEASE TOOL

B. By hand, unscrew inside rose and remove.

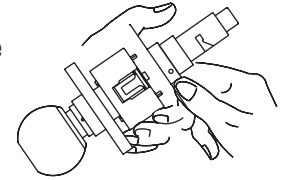

6. INSTALL OUTSIDE KNOB ASSEMBLY

Install outside knob assembly on the door. Make sure tail of latch engages with retractor correctly as illustrated.

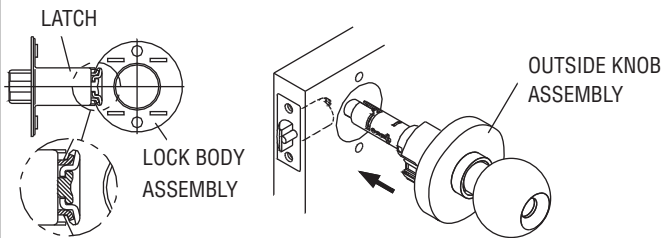

7. ADJUST OUTSIDE ROSE

Lock is pre-set for 1-3/4" door thickness. To fit different door thickness, adjust lock to fit door thickness by rotating outside rose until latch retractor is centered on door centerline. Lock will fit all doors 1-3/8" to 1-3/4" (35 mm - 45 mm) thick.

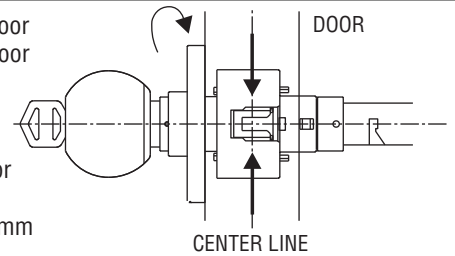

8. INSTALL INSIDE ROSE

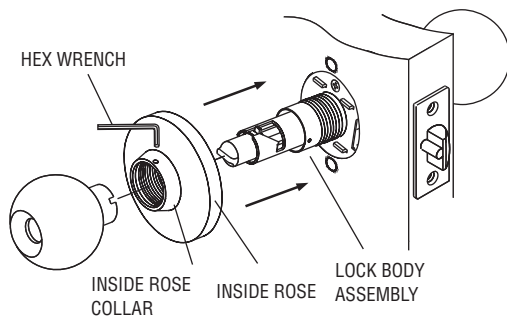

A. To install inside rose, slide inside rose onto lock body assembly so the interior rose tabs face the door. Rotate inside rose collar onto lock body assembly threaded cylinder and screw inside rose collar until tight against door. Use hex wrench tool to securely tighten inside rose collar.

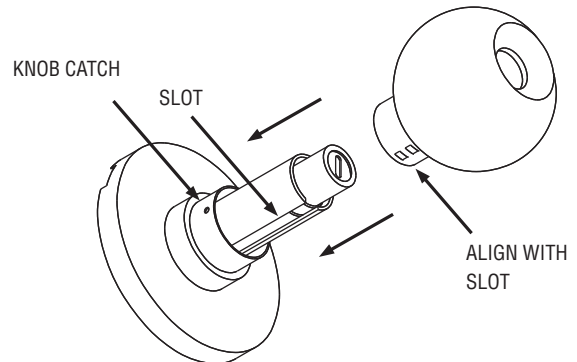

B. To install inside knob, align inside knob with slot and push all the way down until knob locks in place.

9. INSTALL CYLINDER

In the event the keyway was installed in the incorrect, upward position, the knob must be pulled out and installed again. The method of installation is as described below. (NOTE: If installing a 3480 lockset, ignore Step B, and ensure that the key is held in the horizontal position in Step C.)

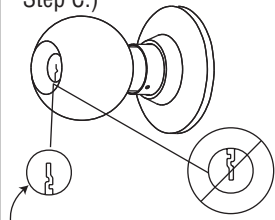

CORRECT KEYWAY POSITION

A. Verify keyway is in the downward position. If not, proceed to steps 9B through 9D.

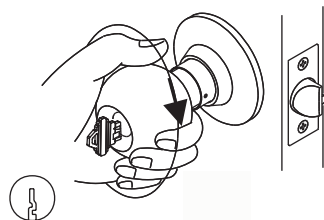

B. Insert key in cylinder. Turn knob clockwise until the Knob Catch appears in the small hole. Use key to ensure cylinder remains in the vertical position.

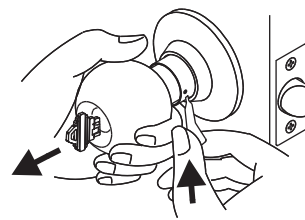

C. Using catch release tool, press the knob catch and pull the knob off.

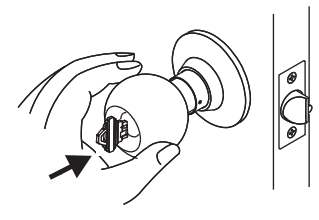

D. Install with keyhole facing upwards.