







Top Hung System

EKU-Divido 100/RSO – Synchro

Order Specifications

- 2 Divido 100/RSO sliding door fitting sets (refer to pages 348–349)
- 1 Divido 100/RSO-Synchro supplementary fitting set
- 1 Single upper running track (refer to page 349)
- 1 Clip-on fascia (refer to page 349)
- 1 End pc. set for clip-on fascia (refer to page 349)
- Aluminum frame profiles (refer to pages 344–345)

Supplementary Fitting Set, for 2 sliding doors without the upper running tracks.

Description	Material/Finish	941.12.004
 Plastic coated ball bearing wheel, mounted horizontally		2 pcs.
 Spacer ring	steel, zinc-plated	2 pcs.
 Rope safe guard	steel, zinc-plated	2 pcs.
 Fixing screw to rope safe guard	steel, zinc-plated	2 pcs.
 Mounting plate for Kevlar rope		2 pcs.
 Kevlar rope, 10.0 m (32' 9 11/16")		1 roll
 Fixing screws	steel, zinc-plated	1 set

Installation Plan: (included in fitting set), mounting instructions for planning and execution available upon request.

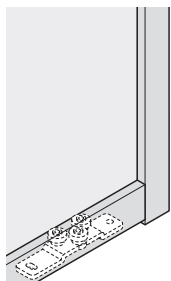

Lower guide without guide channel

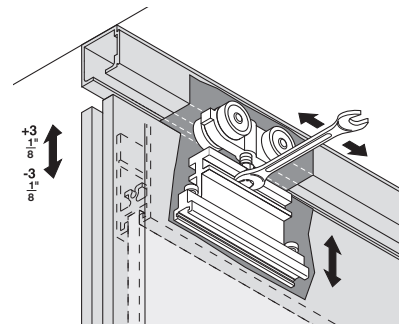
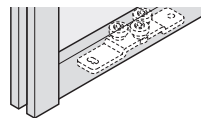

Height adjustment

Dimensional data not binding. We reserve the right to alter specifications without notice.

Dimensions in mm are exact
Inches are approximate