

Top Hung System

HAWA-Junior 80/GP

- For 1 and 2 sliding glass doors
- Smooth, quiet operation
- Maintenance-free
- Vertical adjustment without removing the glass door
- Low installation height
- Rattle-free bottom guide

- Simple installation
- Maximum door weight: **80 kg** (176 lbs.)
- Glass thickness:
Tempered glass: **8,10, 12, 12.7 mm** (5/16" - 1/2")
Laminated glass: **8.7 - 12.7 mm** (5/16" - 1/2")

Installation Tips

When using 2 sliding doors on the same track, please make sure that glass panels do not collide. Please use a lower guide channel with a door stopper or use protective edge trim.

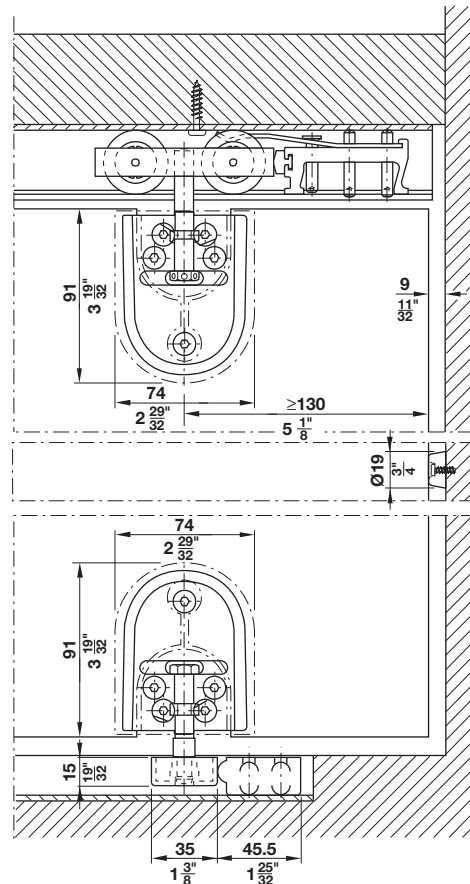
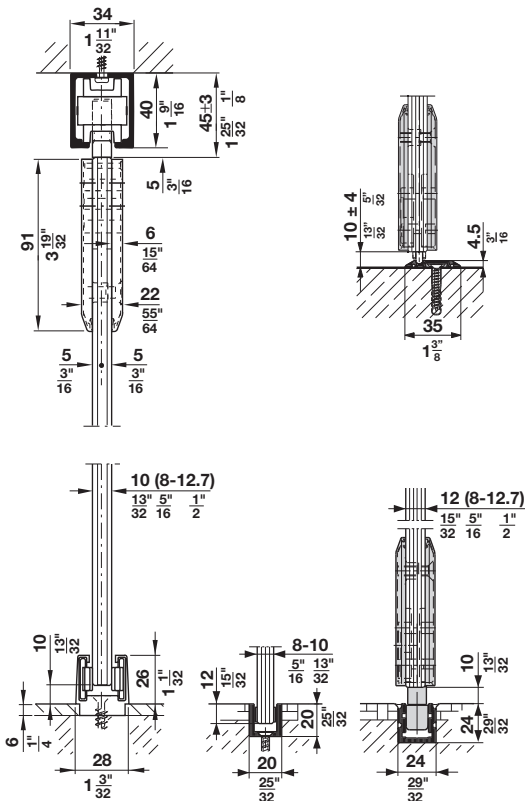
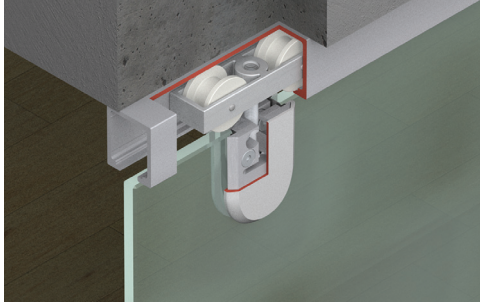

Dimensions in mm are exact
Inches are approximate