

- Store items with the ease of motorization
- For use when greater weight capacity is required
- Store clothing in higher spaces when there is limitation in reach and/or strength
- Accessible without the use of a ladder

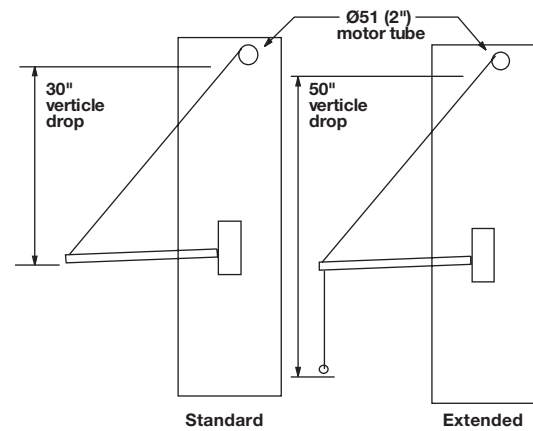
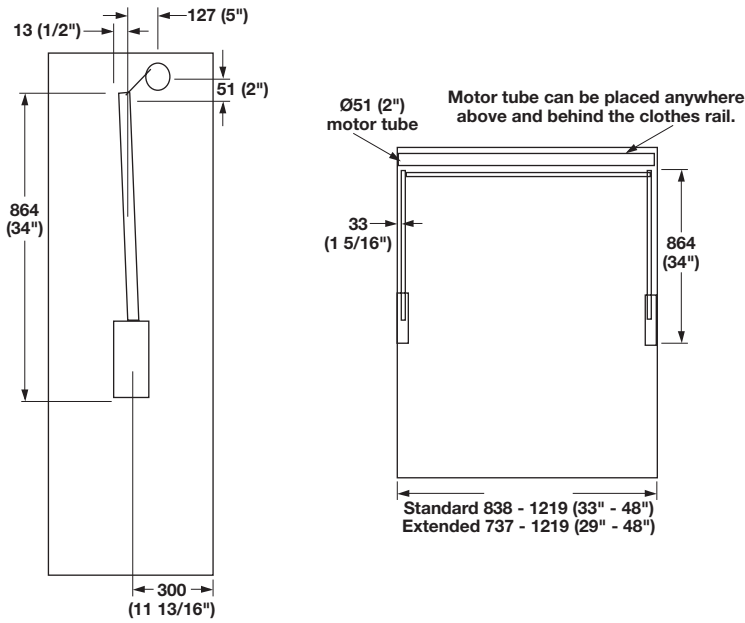

Motorized Wardrobe Lift

- Motorized 110v, electrical plug included but can be hardwired by electrician (220v available on special order)
- Wireless remote, programs upward and lower range of motion

Material: Arms and cross bars: Steel; Housing: Plastic

Lift	Width	Weight capacity	Vertical Lowering Range of clothes rail	Finish: Arm/Housing	Item No.
Standard	33"-48"	60 lbs.	30"	chrome/black	805.32.254
				black/black	805.32.354
Extended	29"-48"	70 lbs.	50"	chrome/black	805.32.262
				black/black	805.32.362

Supplied With

Instructions to size the unit to desired width

Dimensional data not binding. We reserve the right to alter specifications without notice.