

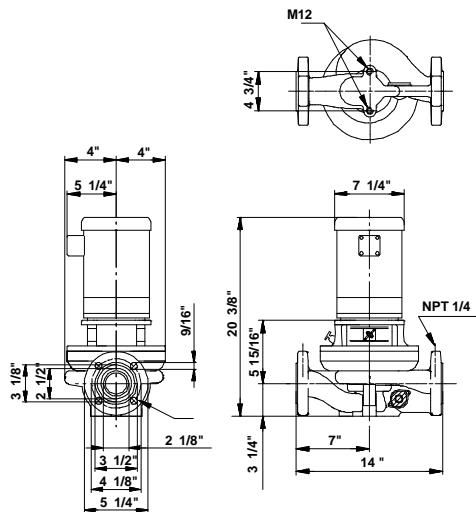

Position	Count	Description	Unit price
	-1	<p>TP 50-160/2 U-G-A-BUBE</p>  <p>Product photo could vary from the actual product</p> <p>Product No.: 96411814 Single-stage centrifugal in-line single-head pump.</p> <p>The in-line design with opposite suction and discharge ports enables mounting in pipework or on a concrete foundation.</p> <p>The shaft seal is a corrosion-resistant maintenance-free mechanical seal.</p> <p>The motor is a 1-phase AC motor.</p> <p>Liquid: Liquid temperature range: 5 .. 284 °F Density: 62.4 lb/ft³</p> <p>Technical: Speed for pump data: 3490 rpm Rated flow: 92.5 US gpm Rated head: 39.4 ft Shaft seal: BUBE Maximum operating pressure: 145 psi Approvals on motor nameplate: UL Recognized Component, CSA</p> <p>Materials: Pump housing: Cast iron EN-JL1040 ASTM 25 B Impeller: Stainless steel DIN W.-Nr. 1.4301 AISI 304</p> <p>Installation: Maximum ambient temperature: 104 °F Maximum operating pressure: 145 psi Flange standard: USA Pipe connection: 2"</p> <p>Electrical data:</p>	On request

Position	Count	Description	Unit price
		Motor type: Baldor, TEFC Number of poles: 2 Rated power - P2: 1.48 HP Main frequency: 60 Hz Rated voltage: 1 x 115/208-230 V Service factor: 1,3 Rated current: 17/9,5-8,6 A Starting current: 79,8/43,8-39,9 A Cos phi - power factor: 79 Rated speed: 3450 rpm Motor efficiency at full load: 71 % Insulation class (IEC 85): B Others: Net weight: 86.4 lb Gross weight: 94.2 lb Shipping volume: 2.33 ft ³	

Description	Value
Product name:	TP 50-160/2 U-G-A-BUBE U-G-A-BUBE
Product Number:	96411814
EAN number:	5700390524777
Technical:	
Speed for pump data	3490 rpm
Rated flow:	92.5 US gpm
Rated head:	39.4 ft
Head max:	52.5 ft
Shaft seal:	BUBE
Maximum operating pressure	145 psi
Approvals on motor nameplate:	UL Recognized Component, CSA
Pump Number:	96405265
Pump version:	U
Materials:	
Pump housing:	Cast iron EN-JL1040 ASTM 25 B
Impeller:	Stainless steel DIN W.-Nr. 1.4301 AISI 304
Material code:	A
Installation:	
Maximum ambient temperature:	104 °F
Maximum operating pressure	145 psi
Flange standard:	USA
Connect code:	G
Pipe connection:	2"
Liquid:	
Liquid temperature range	5 .. 284 °F
Density:	62.4 lb/ft ³
Electrical data:	
Motor type:	Baldor, TEFC
Number of poles:	2
Rated power - P2:	1.48 HP
KVA code:	K
Main frequency:	60 Hz
Rated voltage:	1 x 115/208-230 V
Service factor:	1,3
Rated current:	17,9,5-8,6 A
Starting current	79,8/43,8-39,9 A
Load current:	20,4/11,3-10,2 A
Cos phi - power factor:	79
Rated speed:	3450 rpm
Motor efficiency at full load:	71 %
Insulation class (IEC 85):	B
Motor protection:	CONTACT
Thermal protec:	internal
Motor Number:	85700005
Others:	
Net weight:	86.4 lb
Gross weight:	94.2 lb
Shipping volume:	2.33 ft ³
Country code:	Namreg

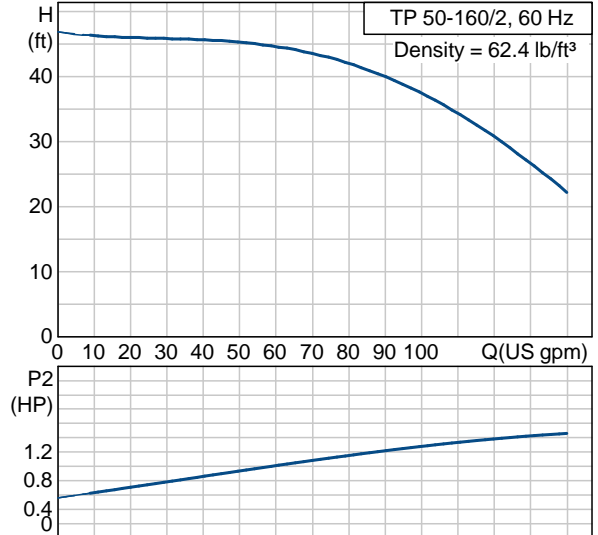

96411814 TP 50-160/2 60 Hz

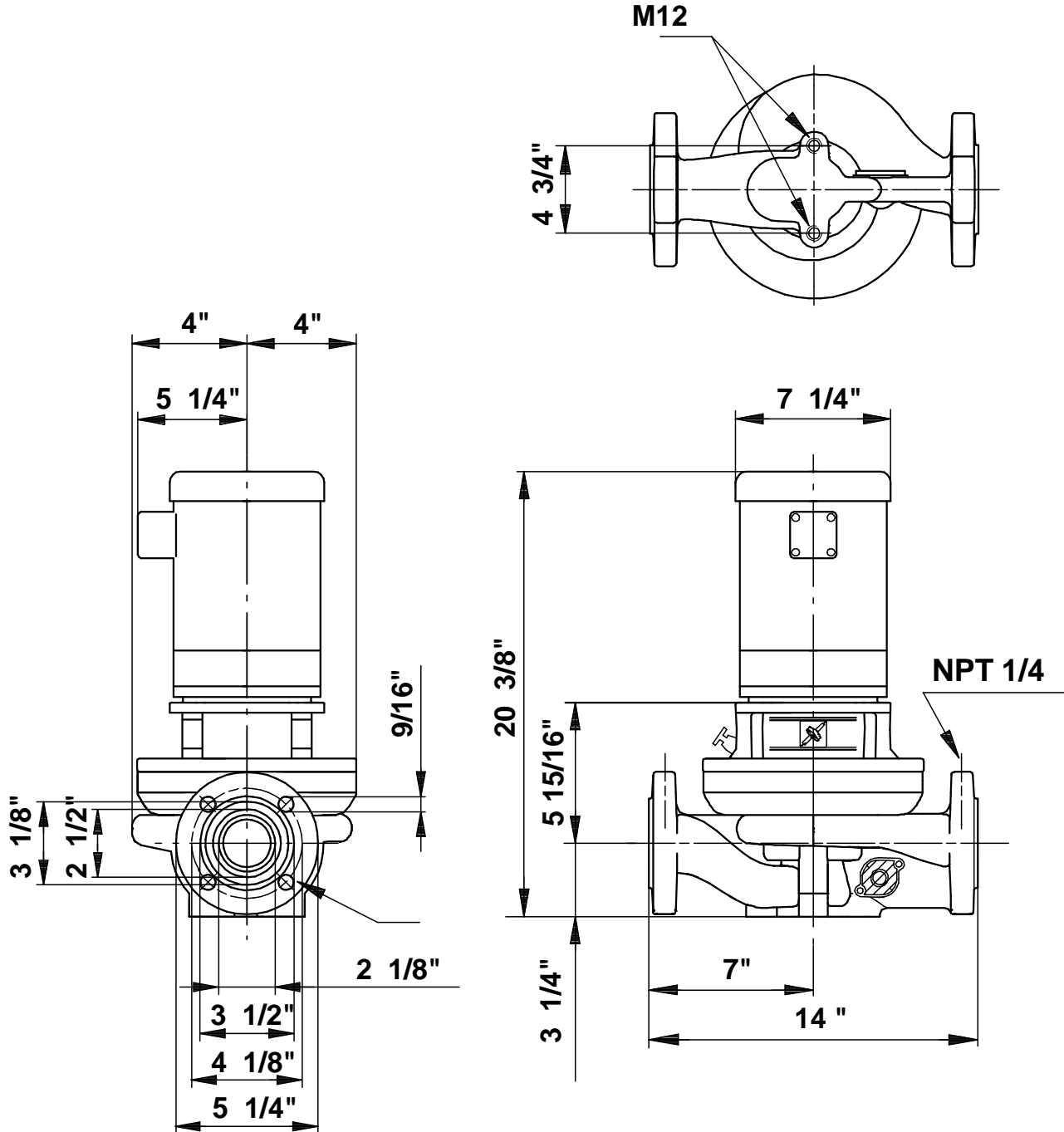

Note! All units are in [mm] unless others are stated.
 Disclaimer: This simplified dimensional drawing does not show all details.