

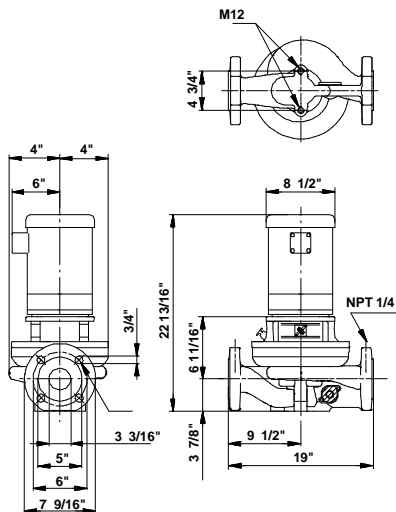

Position	Count	Description	Unit price
	-1	<p><b>TP 80-240/2 U-G-A-BUBE</b></p>  <p>Product photo could vary from the actual product</p> <p>Product No.: 96411839 Single-stage centrifugal in-line single-head pump.</p> <p>The in-line design with opposite suction and discharge ports enables mounting in pipework or on a concrete foundation.</p> <p>The shaft seal is a corrosion-resistant maintenance-free mechanical seal.</p> <p>The motor is a 3-phase AC motor.</p> <p><b>Liquid:</b> Liquid temperature range: 5 .. 284 °F Density: 62.4 lb/ft³</p> <p><b>Technical:</b> Speed for pump data: 3360 rpm Rated flow: 154 US gpm Rated head: 52.2 ft Shaft seal: BUBE Maximum operating pressure: 145 psi Approvals on motor nameplate: UL Recognized Component, CSA</p> <p><b>Materials:</b> Pump housing: Cast iron EN-JL1040 ASTM 25 B Impeller: Stainless steel DIN W.-Nr. 1.4301 AISI 304</p> <p><b>Installation:</b> Maximum ambient temperature: 104 °F Maximum operating pressure: 145 psi Flange standard: ANSI Pipe connection: 3" Pressure stage: 125 Lb.</p>	On request

Position	Count	Description	Unit price
		<p><b>Electrical data:</b></p> <p>Motor type: Baldor, TEFC                      Number of poles: 2                      Rated power - P2: 2.95 HP                      Main frequency: 60 Hz                      Rated voltage: 3 x 208-230/460 V                      Service factor: 1,15                      Rated current: 8,2-7,8/3,9 A                      Starting current: 77,4-70/35 A                      Cos phi - power factor: 89                      Rated speed: 3450 rpm                      Motor efficiency at full load: 81,5 %                      Insulation class (IEC 85): F</p> <p><b>Others:</b></p> <p>Net weight: 139 lb                      Gross weight: 148 lb                      Shipping volume: 4.98 ft<sup>3</sup></p>	

Description	Value
Product name:	TP 80-240/2 U-G-A-BUBE U-G-A-BUBE
Product Number:	96411839
EAN number:	5700390525712
<b>Technical:</b>	
Speed for pump data	3360 rpm
Rated flow:	154 US gpm
Rated head:	52.2 ft
Head max:	78.7 ft
Shaft seal:	BUBE
Maximum operating pressure	145 psi
Approvals on motor nameplate:	UL Recognized Component, CSA
Pump Number:	96405275
Pump version:	U
<b>Materials:</b>	
Pump housing:	Cast iron EN-JL1040 ASTM 25 B
Impeller:	Stainless steel DIN W.-Nr. 1.4301 AISI 304
Material code:	A
<b>Installation:</b>	
Maximum ambient temperature:	104 °F
Maximum operating pressure	145 psi
Flange standard:	ANSI
Connect code:	G
Pipe connection:	3"
Pressure stage:	125 Lb.
<b>Liquid:</b>	
Liquid temperature range	5 .. 284 °F
Density:	62.4 lb/ft <sup>3</sup>
<b>Electrical data:</b>	
Motor type:	Baldor, TEFC
Number of poles:	2
Rated power - P2:	2.95 HP
KVA code:	K
Main frequency:	60 Hz
Rated voltage:	3 x 208-230/460 V
Service factor:	1,15
Rated current:	8,2-7,8/3,9 A
Starting current	77,4-70/35 A
Load current:	9,2-8,8/4,4 A
Cos phi - power factor:	89
Rated speed:	3450 rpm
Motor efficiency at full load:	81,5 %
Insulation class (IEC 85):	F
Motor protection:	NONE
Motor Number:	85600008
<b>Others:</b>	
Net weight:	139 lb
Gross weight:	148 lb
Shipping volume:	4.98 ft <sup>3</sup>
Country code:	Namreg

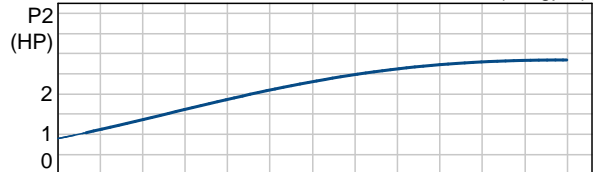
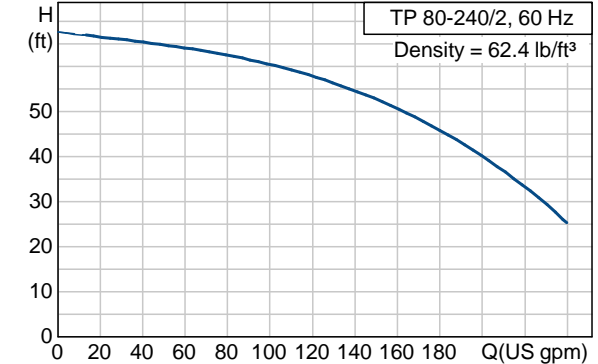

96411839 TP 80-240/2 60 Hz

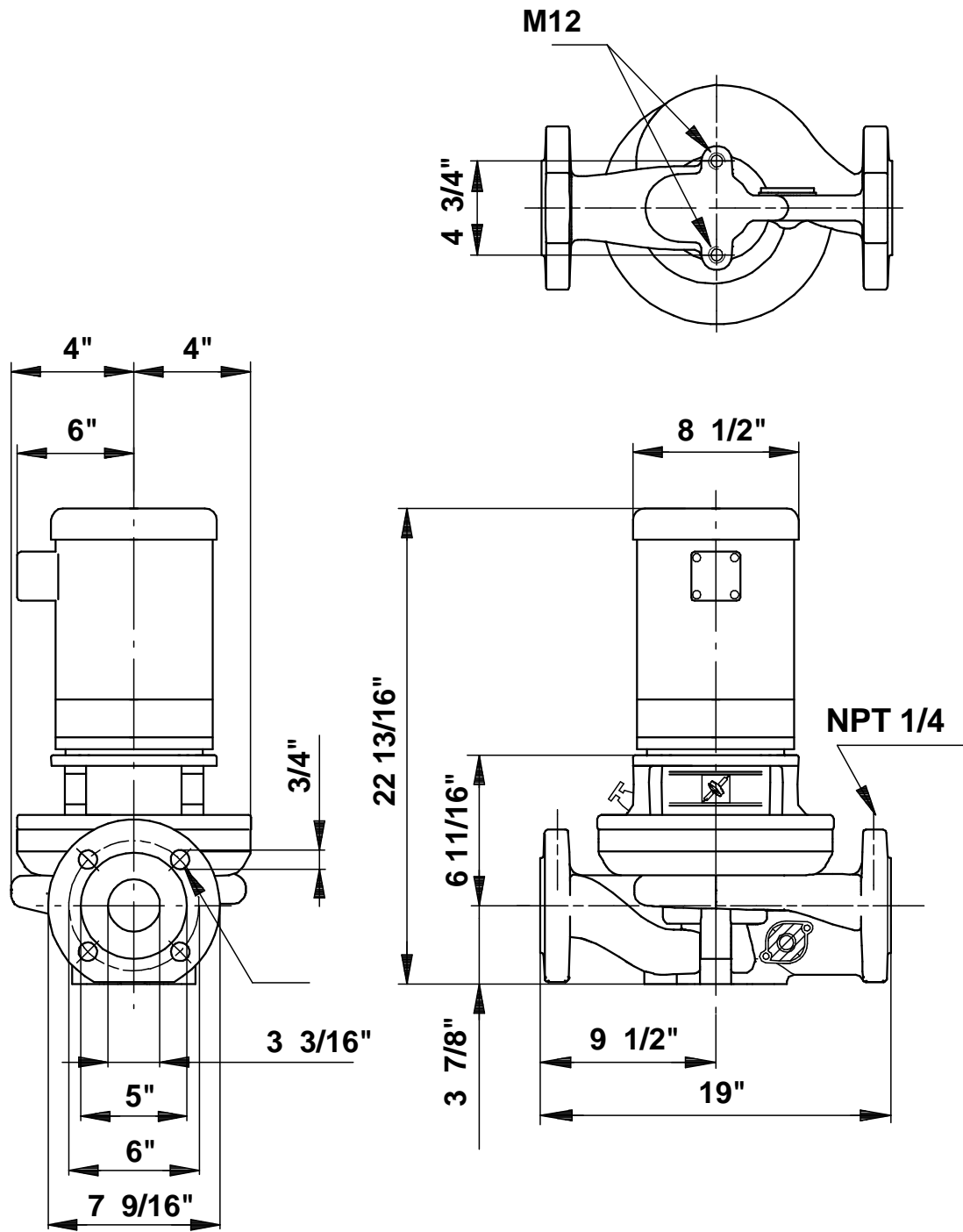

Note! All units are in [mm] unless others are stated.  
 Disclaimer: This simplified dimensional drawing does not show all details.