

20 347

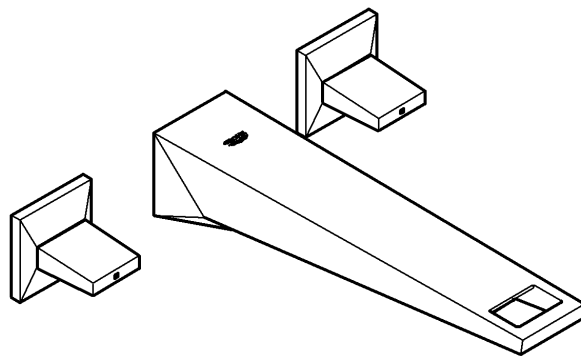

Allure Brilliant

Allure Brilliant

English1

Français1

Español1

Design & Quality Engineering GROHE Germany

99.758.031/ÂM 223870/08.12

GROHE
ENJOY WATER®

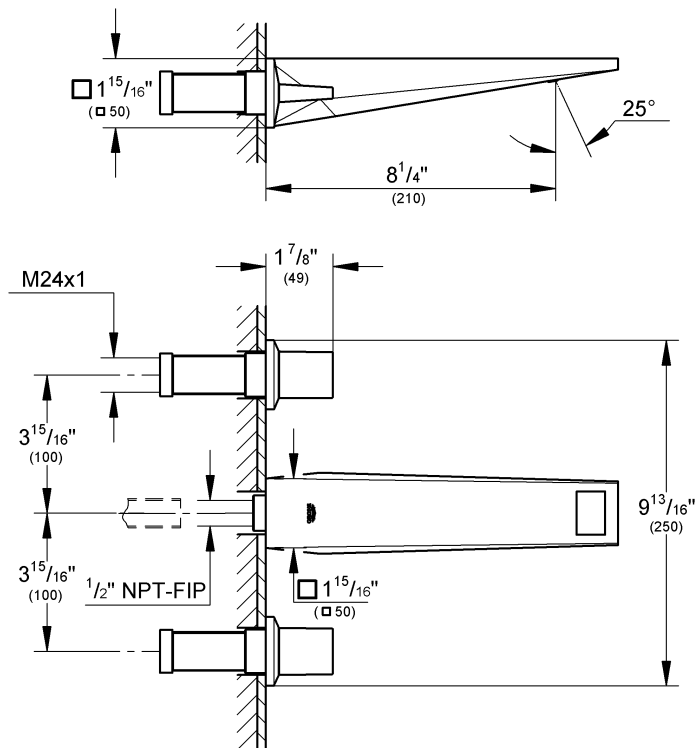
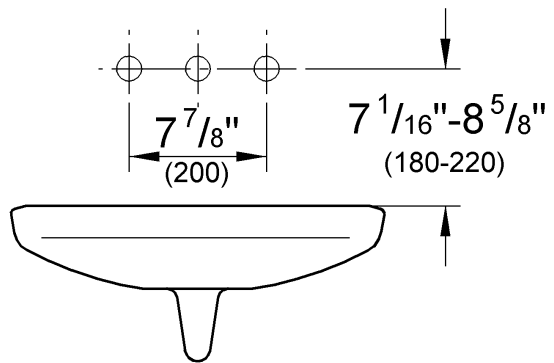

Please pass these instructions on to the end user of the fitting!
 S.v.p remettre cette instruction à l'utilisateur de la robinetterie!
 Entregue estas instrucciones al usuario final de la grifería!

29 031

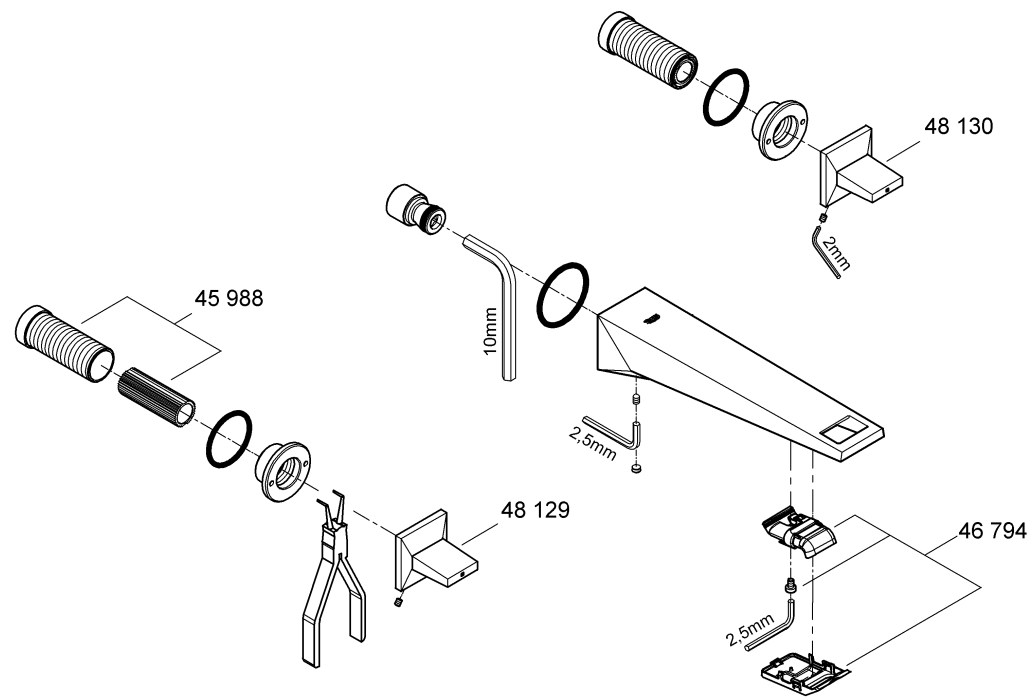
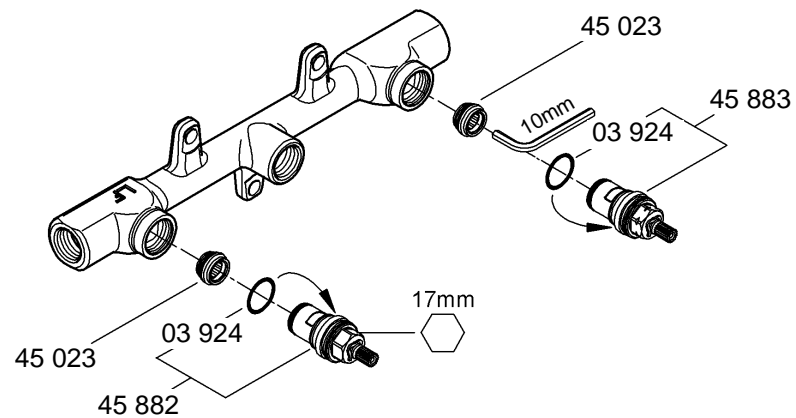

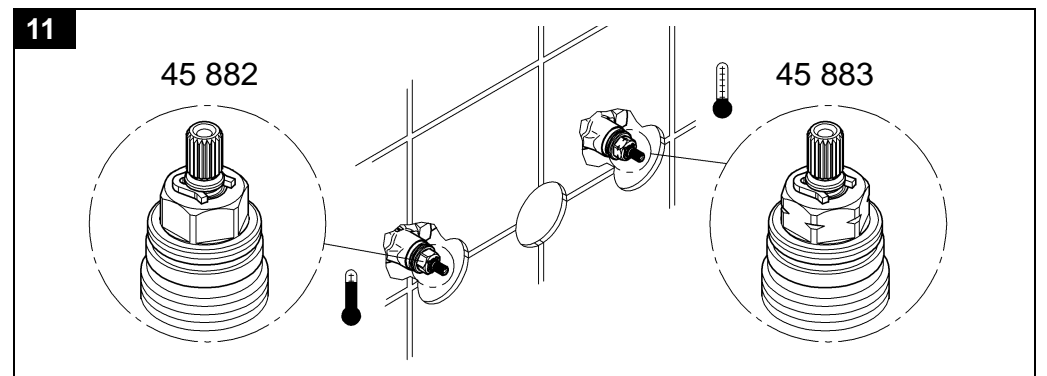
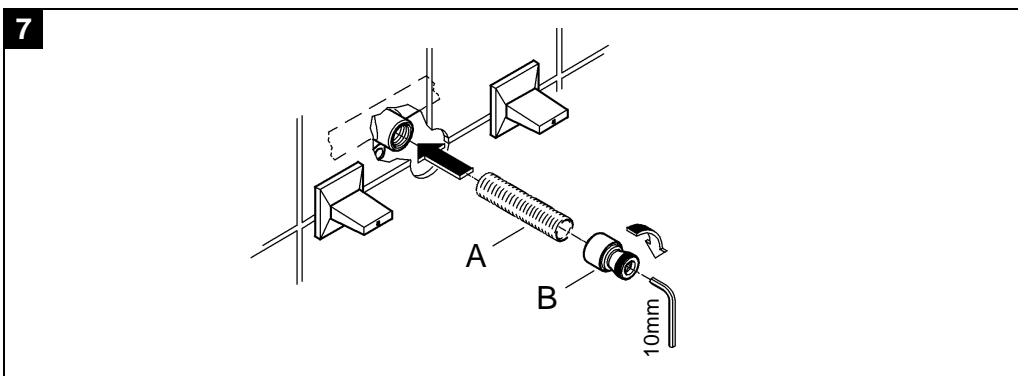
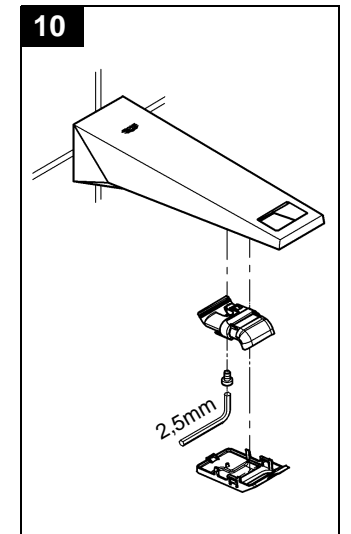
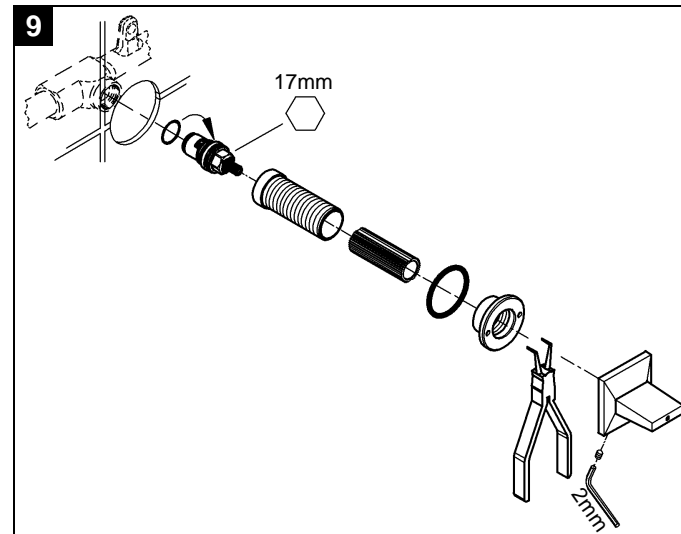
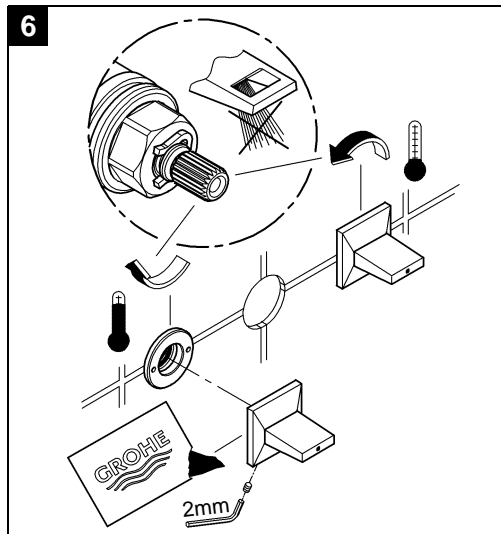
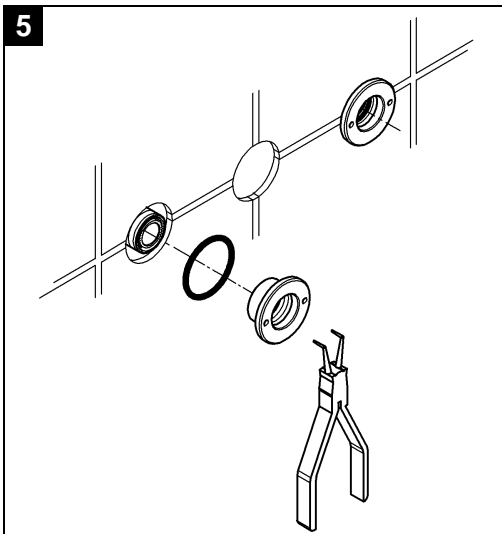
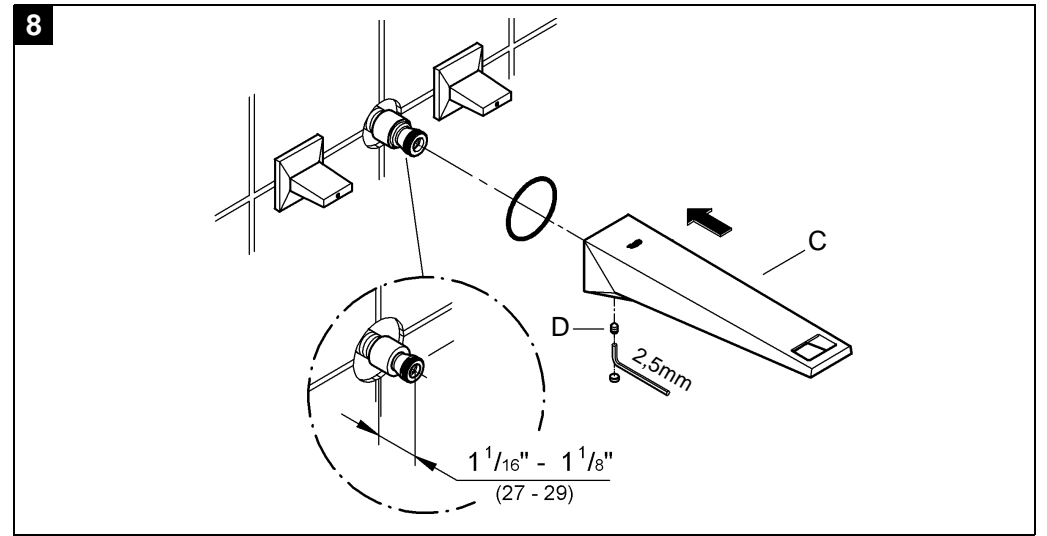
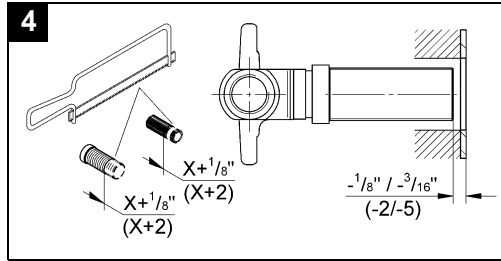
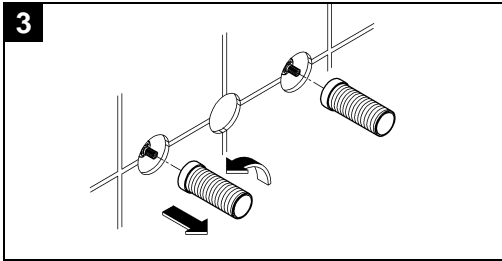
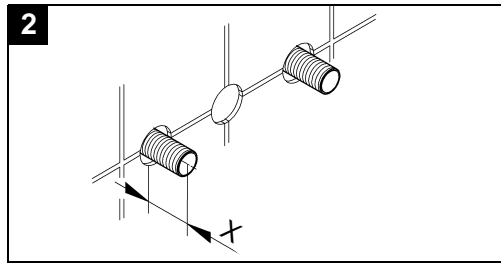
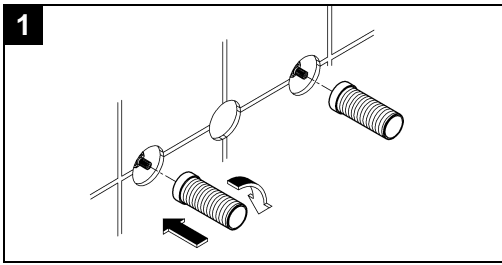

English

Specifications

- Max. flow 5 L/min or 1.3 gpm/60 psi

Installation

Remove fitting templates.

Flush piping system prior and after installation of faucet thoroughly!

Shut off cold and hot water supply.

I. Install side valves, see fold-out page II, Figs. [1] to [6].

Crosscut extension sleeve with spindle extension so that the installation dimension is **-1/8" to max -3/16"**, see Fig. [4].

II. Install spout, see Figs. [7] and [8].

1. Screw in 1/2" NPT-adaptor (A), **sold separately**, to concealed mixer housing, see Fig. [7].
2. Screw on connection nipple (B) using an 10mm allen wrench.
3. Crosscut 1/2" NPT-adaptor in that way, that the installation dimension is **1 1/16" to max 1 1/8"**, see Fig. [8].

4. Tighten the spout (C) with set screw (D), using an 2.5mm allen wrench.

Open cold and hot water supply and check connections for leakage!

Maintenance

Inspect and clean all parts, replace as necessary and grease with special grease.

Shut off cold and hot water supply!

I. Headpart, see Figs. [9] and [11].

II. Race (46 794), see Fig. [10].

Replacement parts, see fold-out page I.

Care

For directions on the care of this fitting, please refer to the accompanying Care Instructions.

Français

Caractéristiques techniques

- Débit maxi. 5 l/min ou 1,3 g/min/4,1 bar

Installation

Enlever les gabarits de montage.

Bien rincer les canalisations avant et après l'installation! Couper l'alimentation en eau chaude et en eau froide.

I. Montage des robinets d'arrêt, voir volet II, fig. [1] à [6].

Couper à la bonne longueur la douille de protection avec la prolongation de tige, pour obtenir une dimension de montage comprise **entre -2mm minimum et -5mm maximum**, voir fig. [4].

II. Montage du bec, voir fig. [7] et [8].

1. Visser le 1/2" NPT-adaptateur (A), **non fourni**, au corps encastré, voir fig. [7].
2. Visser la nipple de raccordement (B) à l'aide d'une clé Allen de 10mm.
3. Couper à la bonne longueur la 1/2" NPT-adaptateur pour obtenir une dimension de montage comprise entre **27mm**

minimum et 29mm maximum, voir fig. [8].

4. Fixer le bec (C) avec la vis (D) à l'aide d'une clé Allen de 2,5mm.

Ouvrir l'arrivée d'eau froide et d'eau chaude et vérifier l'étanchéité des raccordements.

Maintenance

Contrôler toutes les pièces, les nettoyer, les remplacer si nécessaire et les graisser avec de la graisse spéciale pour robinetterie.

Couper l'alimentation en eau chaude et en eau froide.

I. Tête, voir fig. [9] et [11].

II. Conduite d'eau (46 794), voir fig. [10].

Pièces de rechange, voir la volet I.

Entretien

Les indications relatives à l'entretien de cette robinetterie figurent sur la notice jointe à l'emballage.

Español

Datos técnicos

- Caudal máx. 5 L/min o 1.3 gpm/60 psi

Instalación

Quitar los patrones de montaje.

¡Purgar a fondo el sistema de tuberías antes y después de la instalación!

Cerrar las llaves de paso del agua fría y del agua caliente.

I. Montaje de las válvulas laterales, véase la página desplegable II, figs. [1] a [6].

Cortar el casquillo de prolongación con la prolongación del husillo de modo que resulte una cota de montaje de **-1/8" hasta como máx -3/16"**, véase la fig. [4].

II. Montaje del caño, véanse figs. [7] y [8].

1. Enroscar el 1/2" NPT-adaptador (A), **no contenido en el volumen suministro**, a la cuerpo encontrable, véase la fig. [7].
2. Enroscar el casquillo roscado de conexión (B) con una llave Allen de 10mm.

3. Cortar a medida el 1/2" NPT-adaptador de modo que resulte una cota de montaje de **min 1 1/16" hasta máx 1 1/8"**, véase la fig. [8].

4. Fijar el caño (C) con el tornillo prisionero (D) con una llave Allen de 2,5mm.

Abrir las llaves de paso del agua fría y del agua caliente y comprobar la estanqueidad de las conexiones.

Mantenimiento

Verificar todas las piezas, limpiarlas, cambiarlas en caso de necesidad y engrasarlas con grasa especial para griferías.

Cerrar las llaves de paso del agua fría y del agua caliente.

I. Montura, véanse las figs. [9] y [11].

II. Conducción de agua (46 794), véase la fig. [10].

Repuestos, véase la página desplegable I.

Cuidado

Las instrucciones para el cuidado de este producto pueden consultarse en las instrucciones de conservación adjuntas.



www.grohe.com

Grohe America Inc. 241 Covington Drive Bloomington, IL 60108 U.S.A. Technical Services Phone: 630/582-7711 Fax: 630/582-7722	Grohe Canada Inc. 1230 Lakeshore Road East Mississauga, Ontario Canada, L5E 1E9 Technical Services Services Techniques Phone/Tél: 905/271-2929 Fax/Télécopieur: 905/271-9494
---	---