

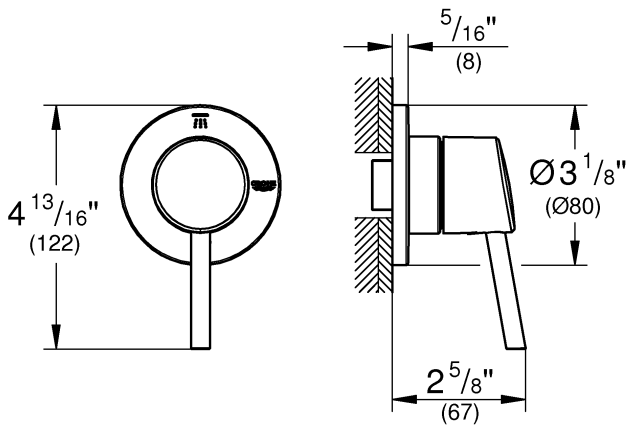

29 104

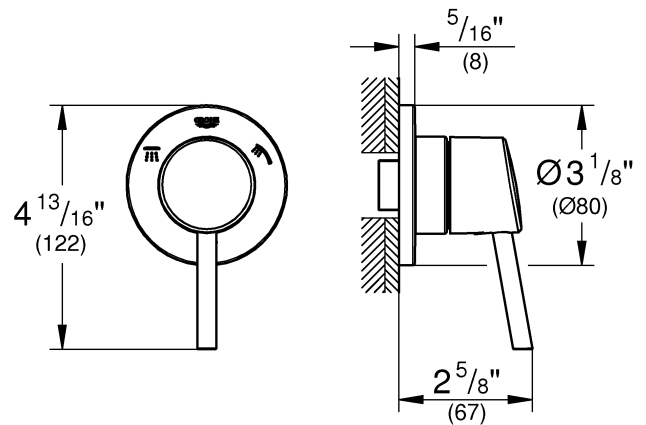

29 106



29 108

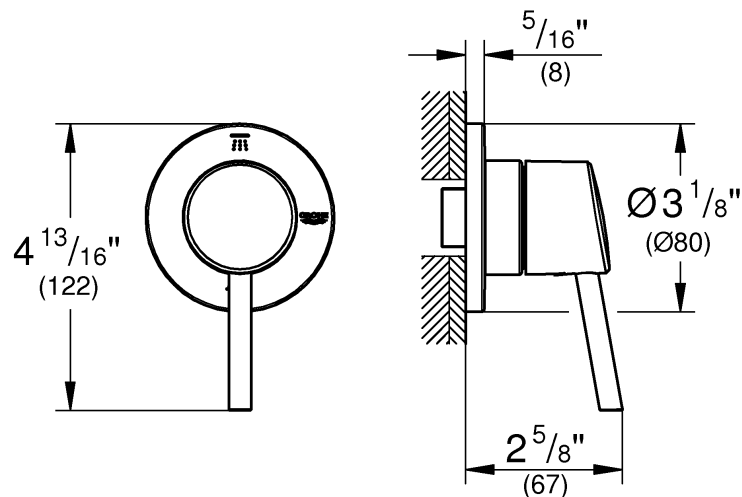

1



2 - 3

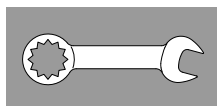

4



5



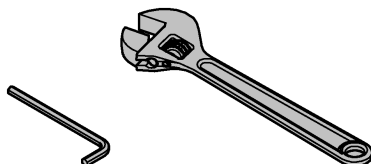
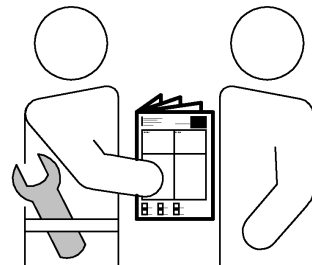
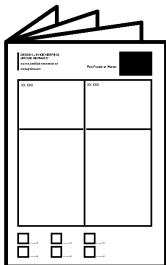
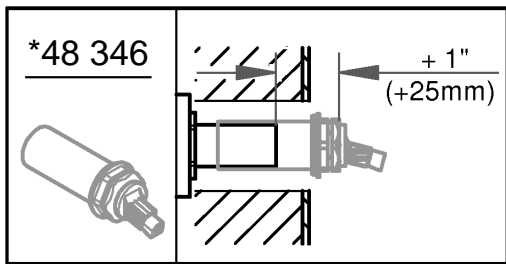
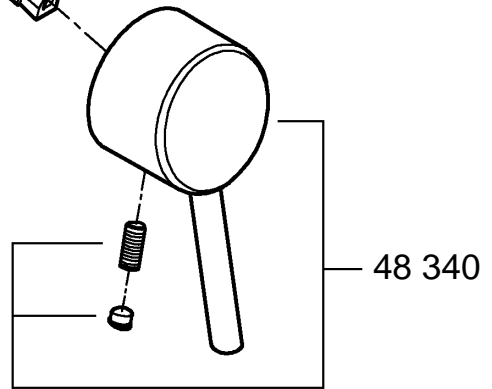
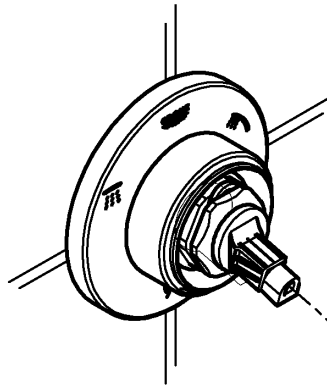
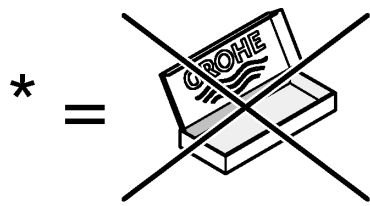



29 104

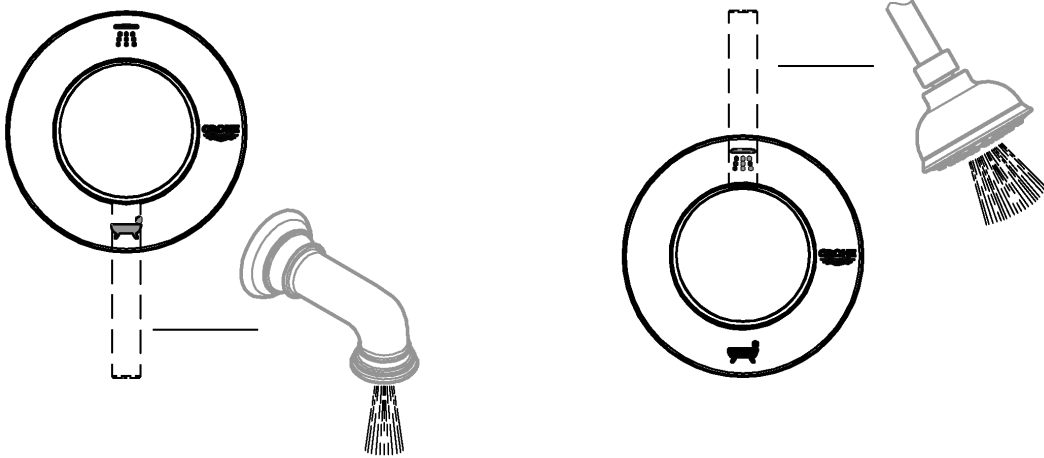

29 106

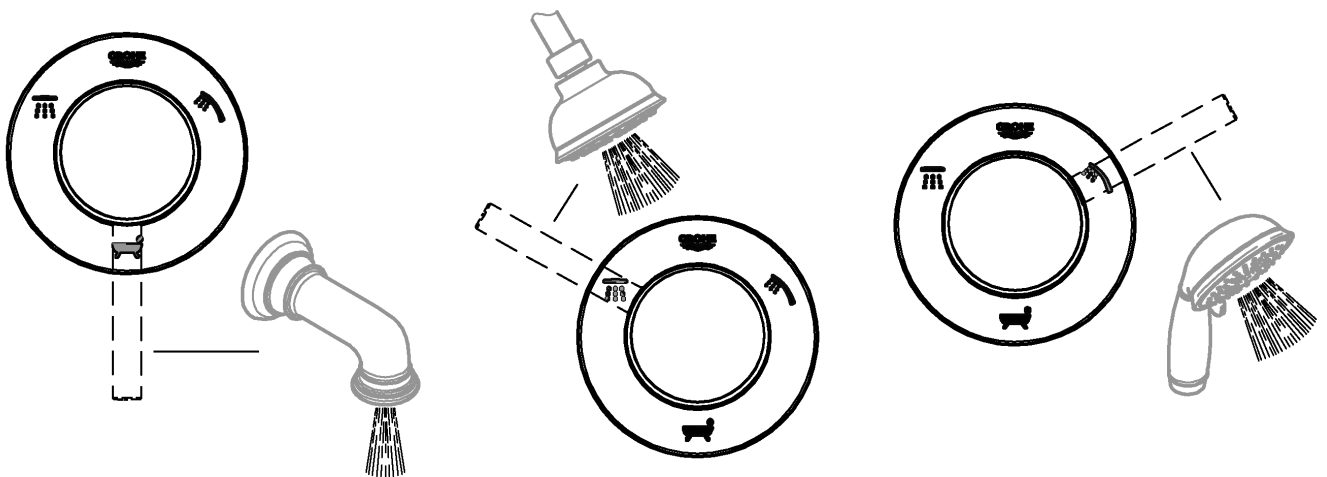

29 108

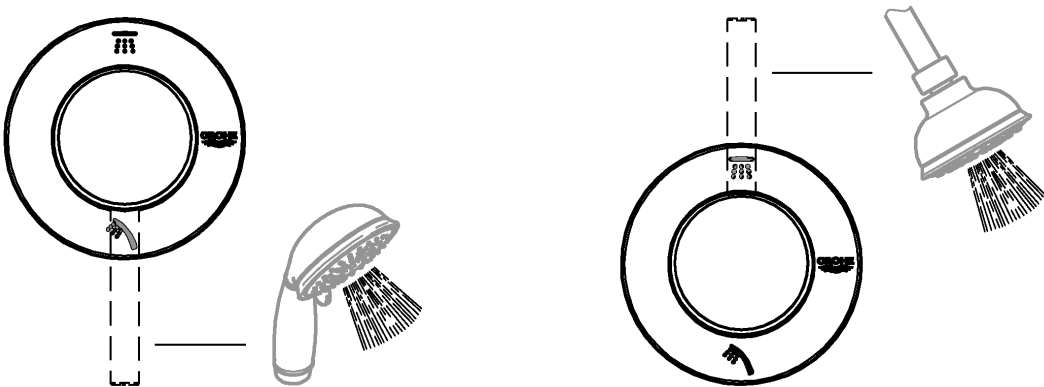



29 104

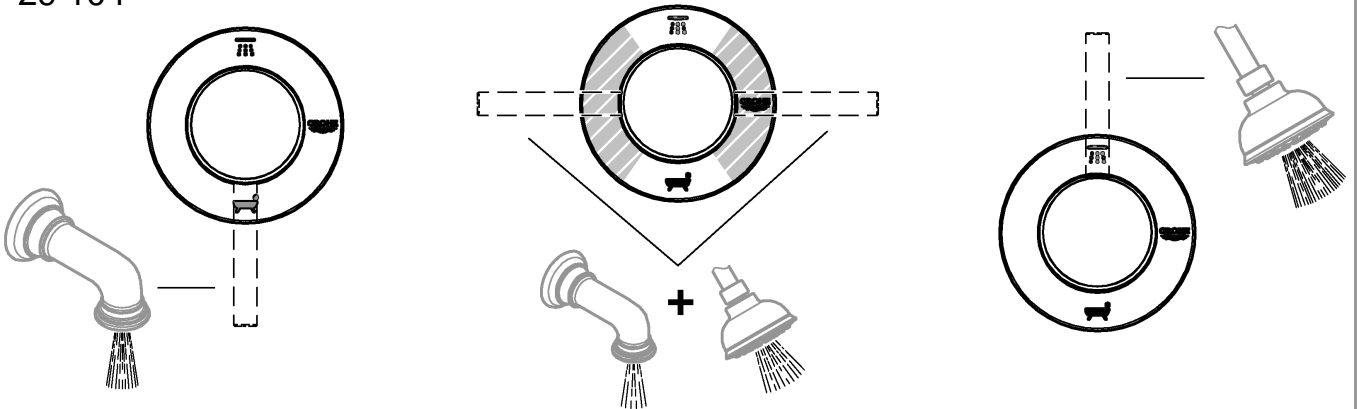

29 106

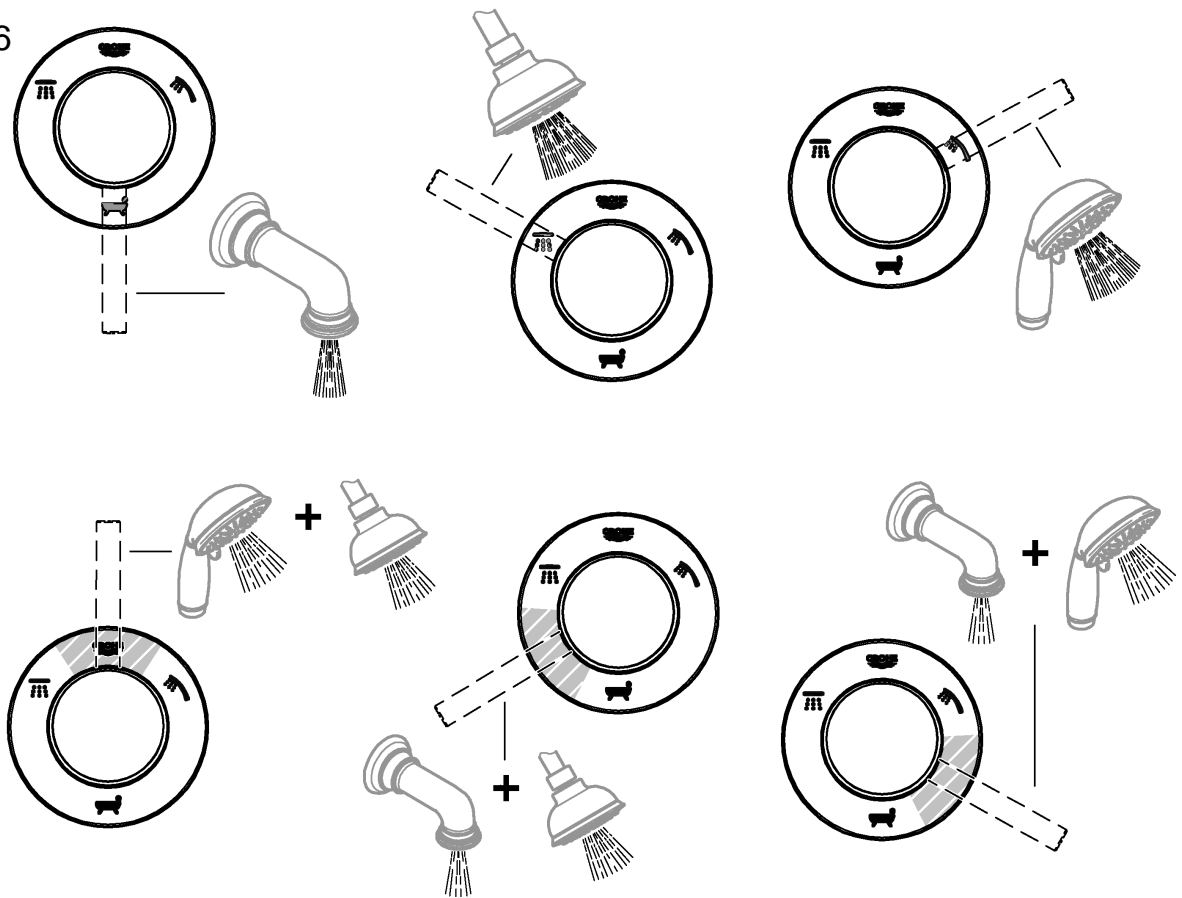

29 108

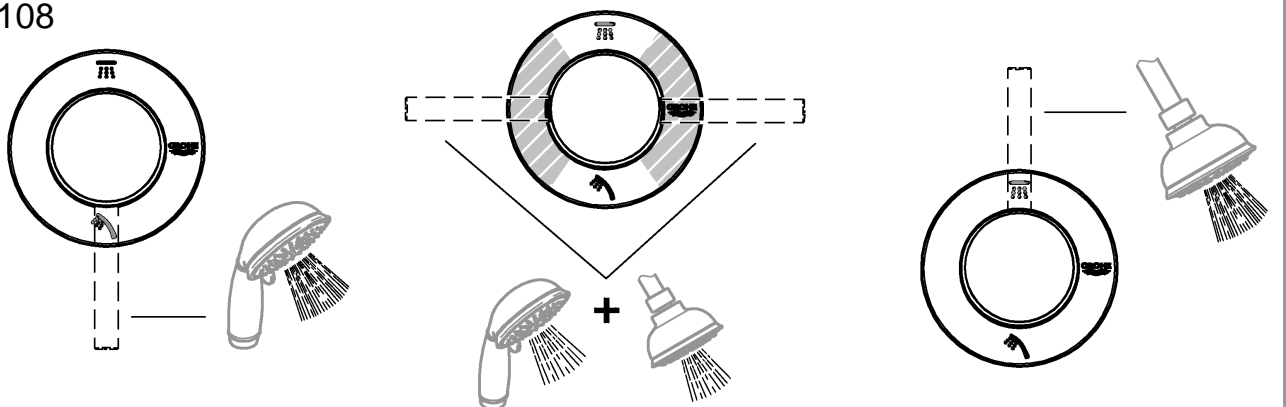

Pure Freude an Wasser

GROHE
WAVES

D

+49 571 3989 333
impressum@grohe.de

A

+43 1 68060
info-at@grohe.com

AUS

Argent Sydney
+(02) 8394 5800
Argent Melbourne
+(03) 9682 1231

B

+32 16 230660
info.be@grohe.com

BG

+359 2 9719959
grohe-bulgaria@grohe.com

CAU

+99 412 497 09 74
info-az@grohe.com

CDN

+1 888 6447643
info@grohe.ca

CH

+41 448777300
info@grohe.ch

CN

+86 21 63758878

CY

+357 22 465200
info@grome.com

CZ

+420 277 004 190
grohe-cz@grohe.com

DK

+45 44 656800
grohe@grohe.dk

E

+34 93 3368850
grohe@grohe.es

EST

+372 6616354
grohe@grohe.ee

F

+33 1 49972900
marketing-fr@grohe.com

FIN

+358 10 8201100
teknocalor@teknocalor.fi

GB

+44 871 200 3414
info-uk@grohe.com

GR

+30 210 2712908
nsapountzis@ath.forthnet.gr

H

+36 1 2388045
info-hu@grohe.com

HK

+852 2969 7067
info@grohe.hk

I

+39 2 959401
info-it@grohe.com

IND

+91 124 4933000
customer-care.in@grohe.com

IS

+354 515 4000
jonst@byko.is

J

+81 3 32989730
info@grohe.co.jp

KZ

+7 727 311 07 39
info-cac@grohe.com

LT

+372 6616354
grohe@grohe.ee

LV

+372 6616354
grohe@grohe.ee

MAL

+1 800 80 6570
info-singapore@grohe.com

N

+47 22 072070
grohe@grohe.no

NL

+31 79 3680133
vragen-nl@grohe.com

NZ

+09/373 4324

P

+351 234 529620
commercial-pt@grohe.com

PL

+48 22 5432640
biuro@grohe.com.pl

RI

+62 21 2358 4751
info-singapore@grohe.com

RO

+40 21 2125050
info-ro@grohe.com

ROK

+82 2 559 0790
info-singapore@grohe.com

RP

+63 2 8041617

RUS

+7 495 9819510
info@grohe.ru

S

+46 771 141314
grohe@grohe.se

SGP

+65 6 7385585
info-singapore@grohe.com

SK

+420 277 004 190
grohe-cz@grohe.com

T

+66 2610 3685
info-singapore@grohe.com

TR

+90 216 441 23 70
GroheTurkey@grome.com

UA

+38 44 5375273
info-ua@grohe.com

USA

+1 800 4447643
us-customerservice@grohe.com

VN

+84 8 5413 6840
info-singapore@grohe.com

AL **BiH** **HR** **KS**

ME **MK** **SLO** **SRB**

+385 1 2911470
adria-hr@grohe.com

**Eastern Mediterranean,
Middle East - Africa**

Area Sales Office:
+357 22 465200
info@grome.com

IR **OM** **UAE** **YEM**

+971 4 3318070
grohedubai@grome.com

Far East Area Sales Office:

+65 6311 3600
info@grohe.com.sg



29 100

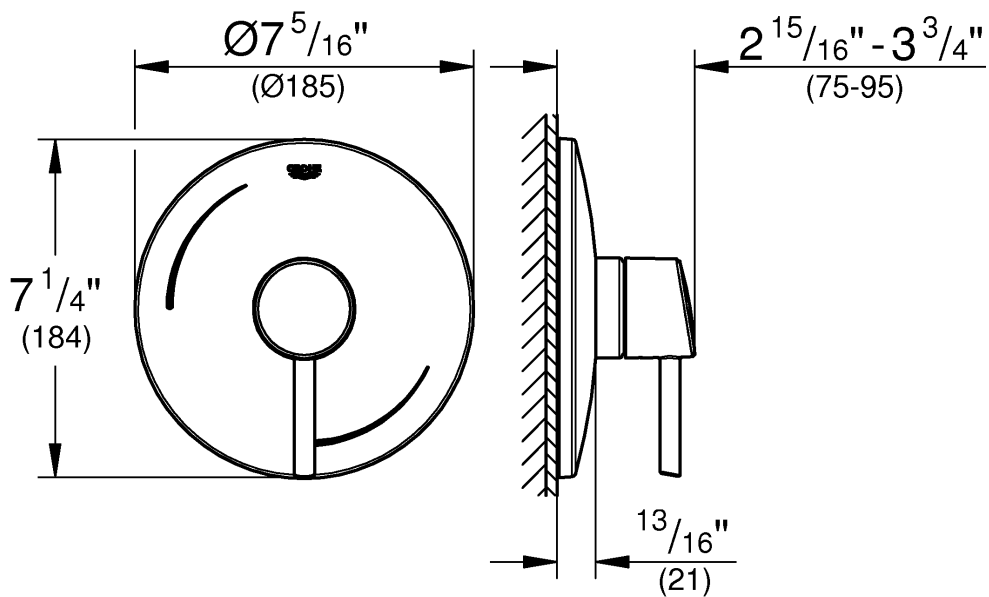
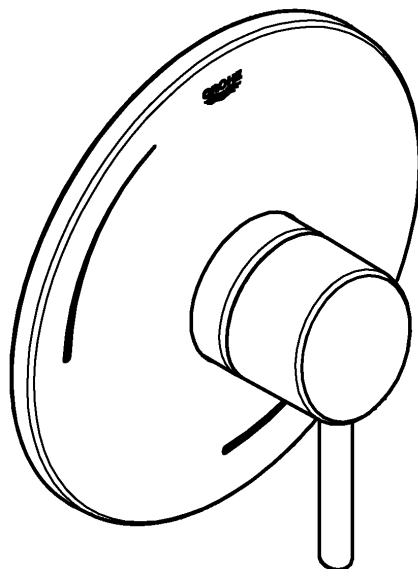

1



6 - 7



2 - 3

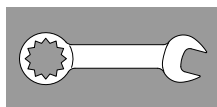

7



3



8



4 - 5

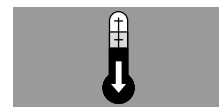

9



English
 Français
 Español

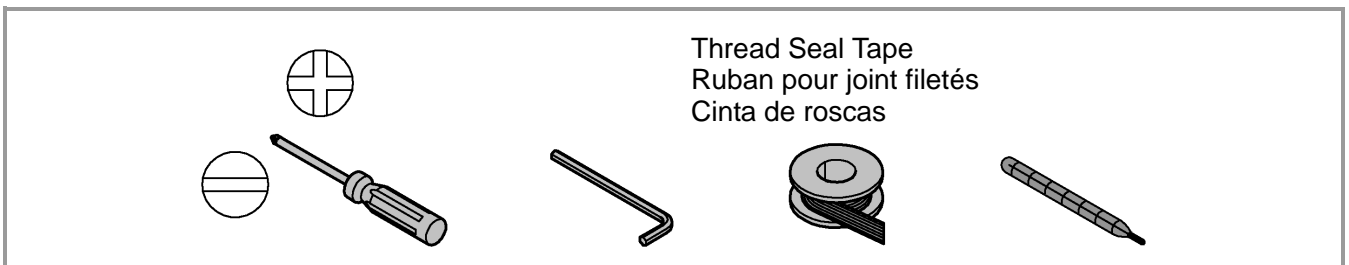
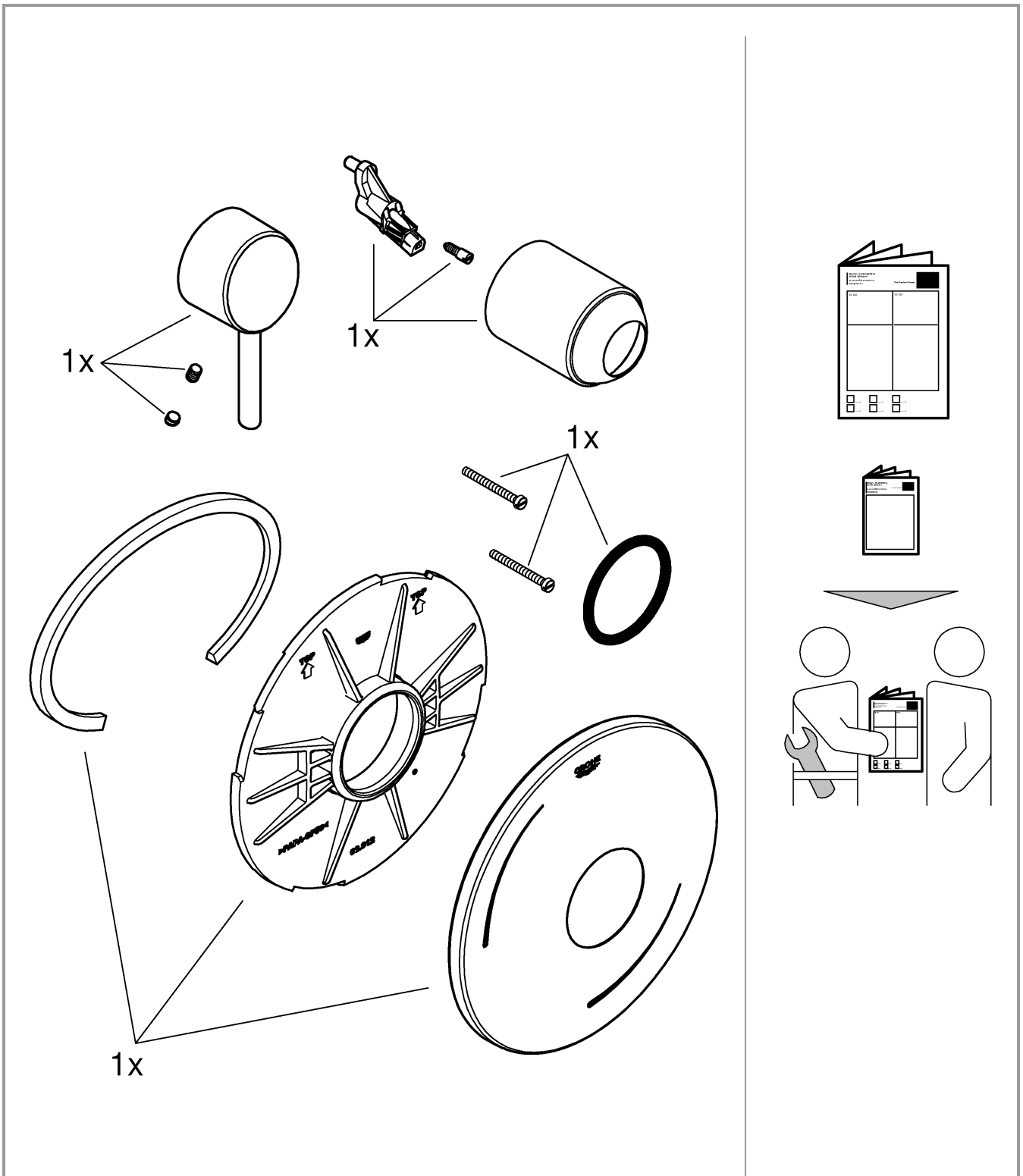



1

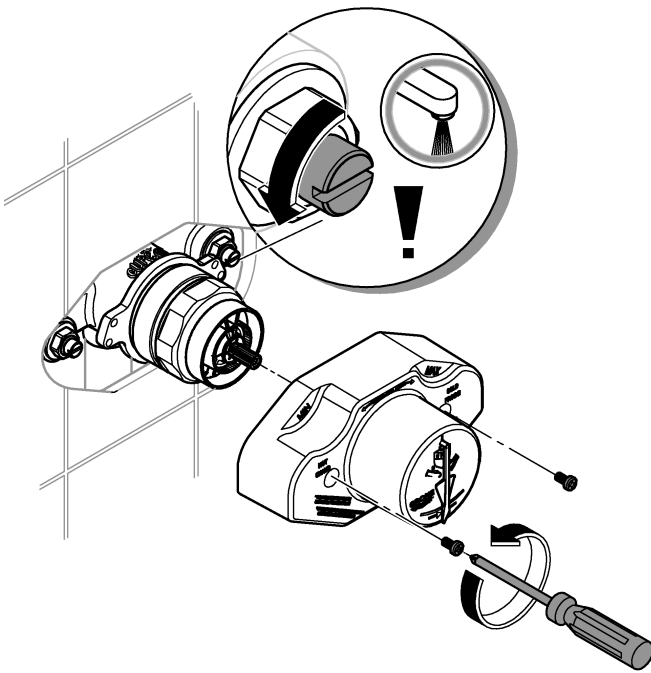

2

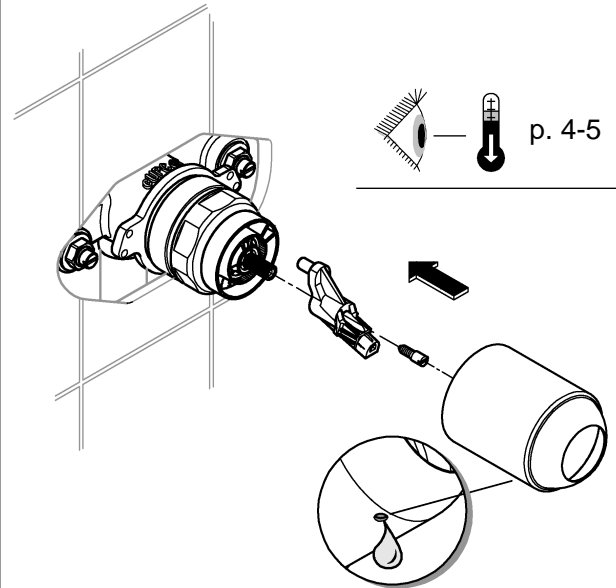

3

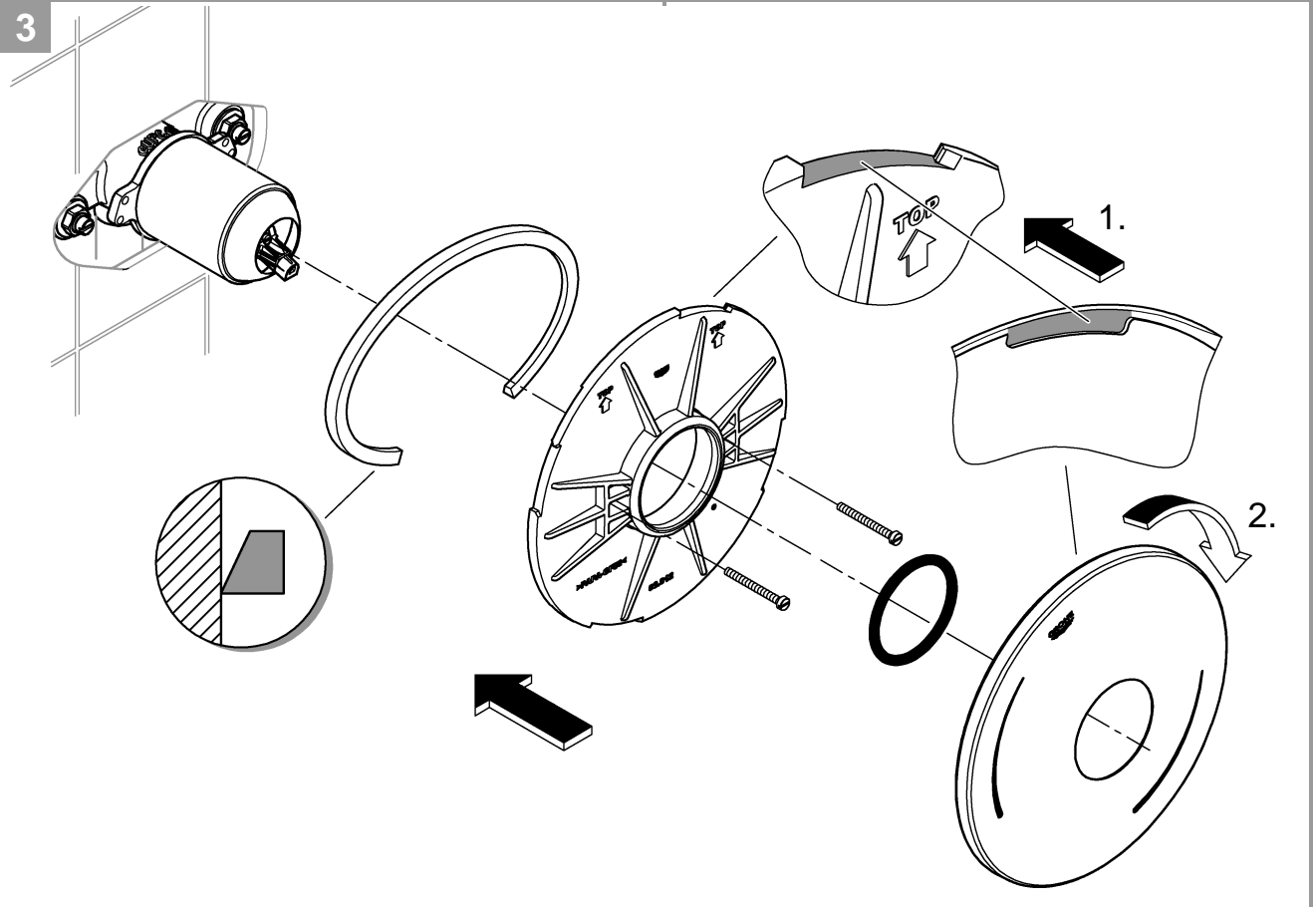



4

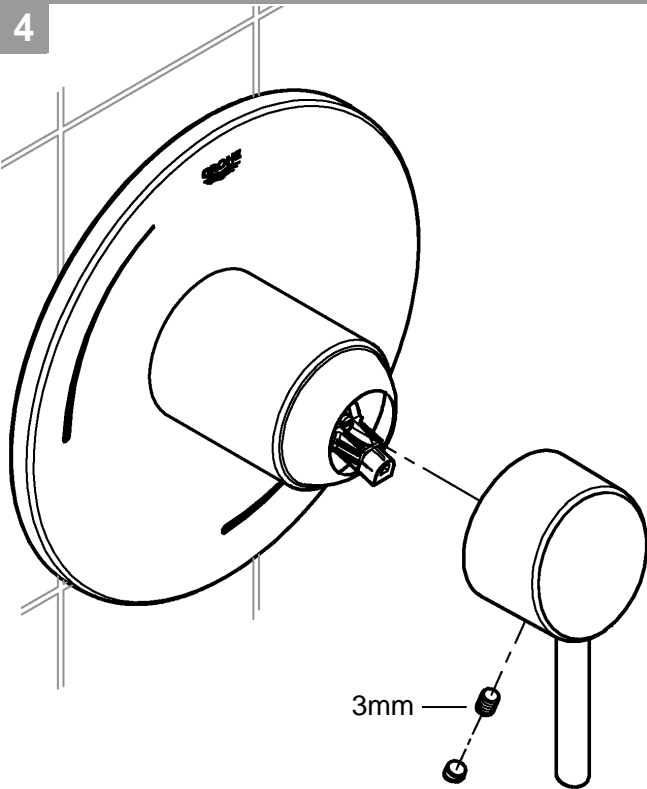

5

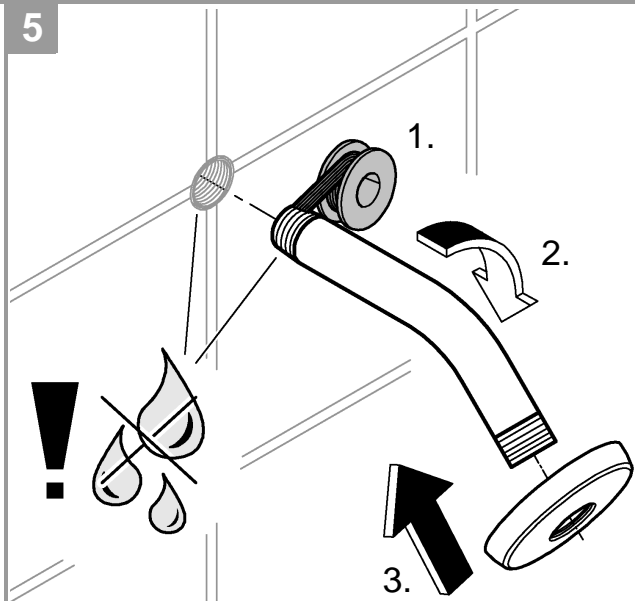

Only for 35 073 and 35 075
Seulement pour 35 073 et 35 075
Sólo para 35 073 y 35 075

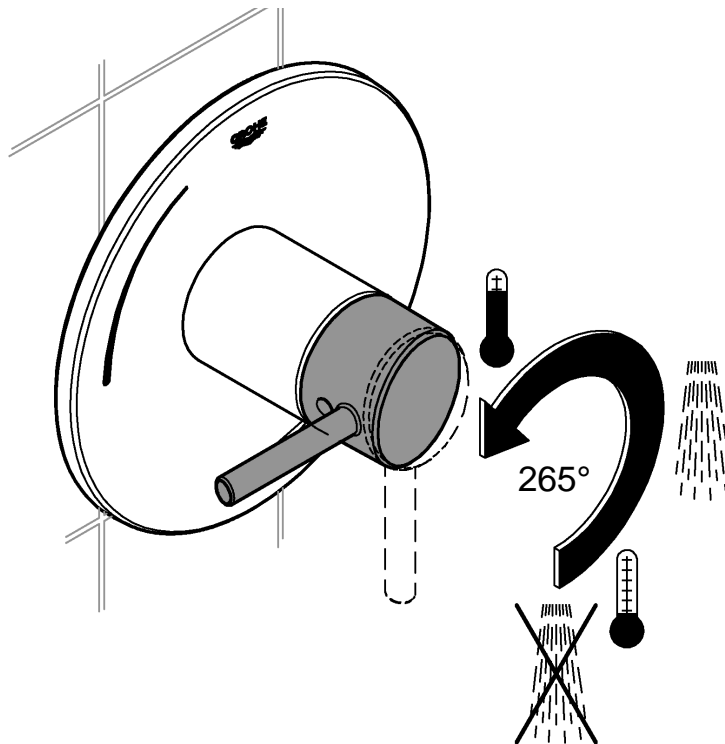



4

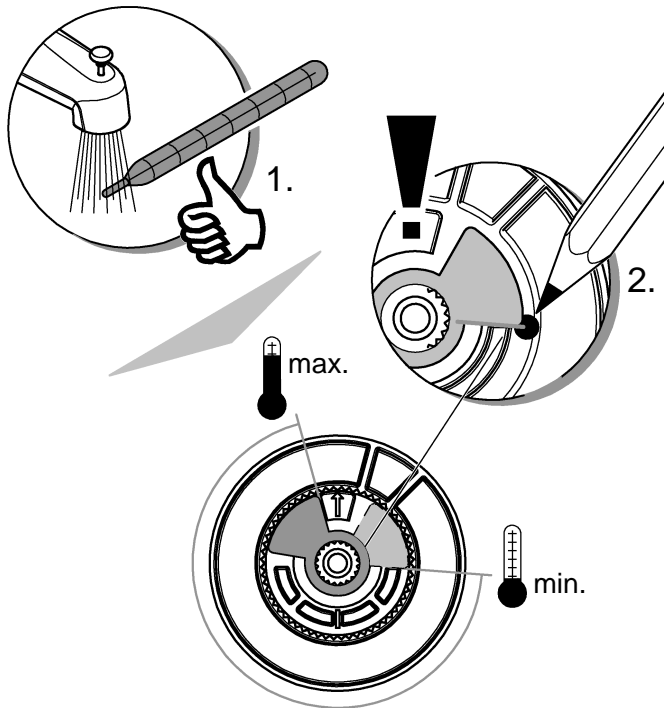

5

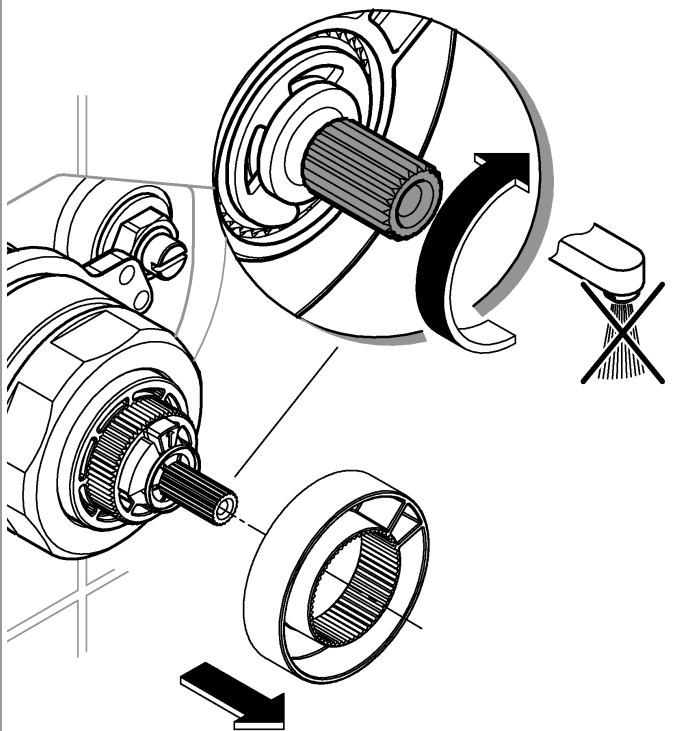

6

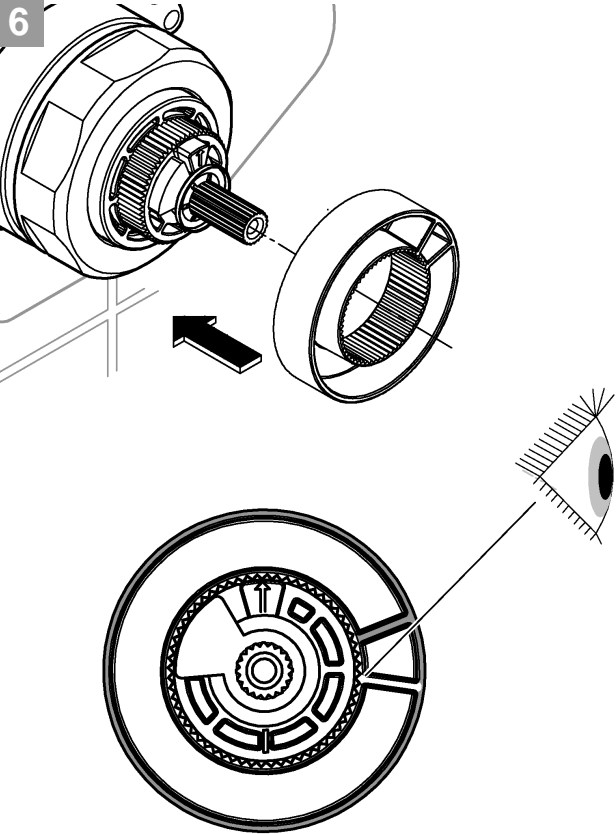

4

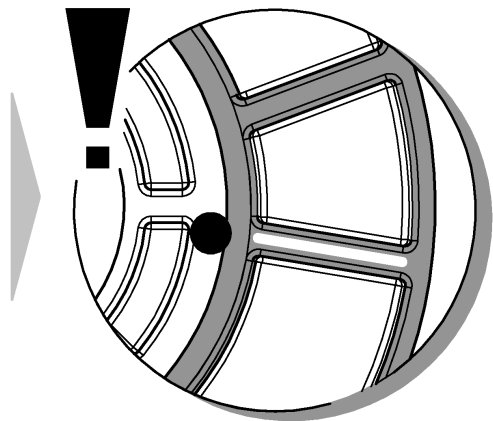

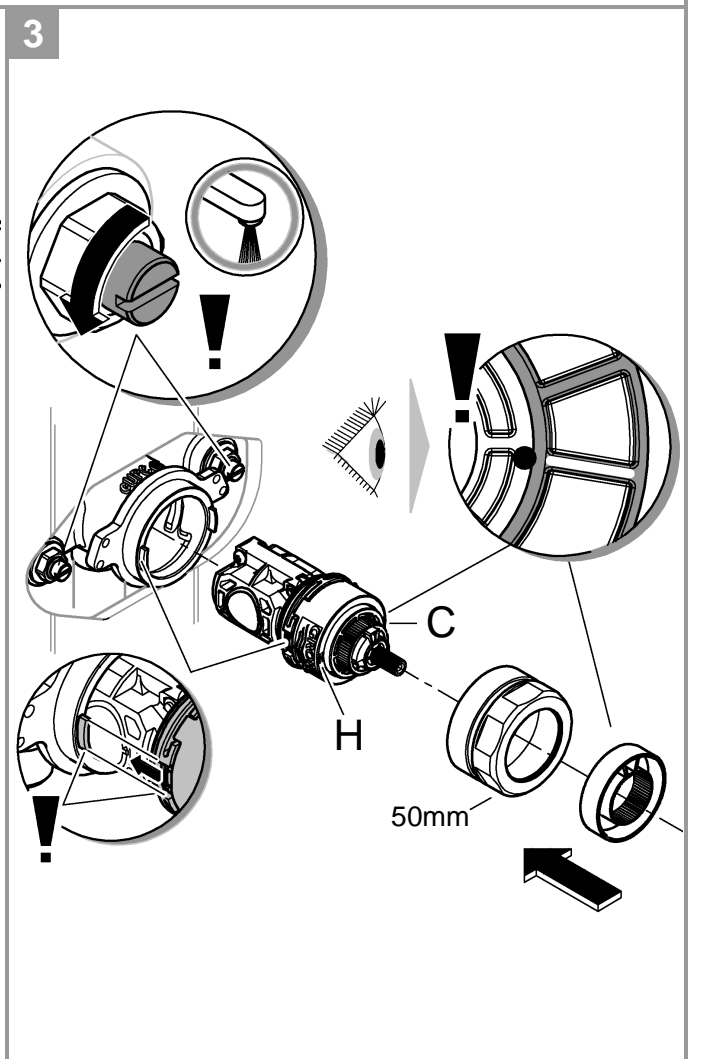
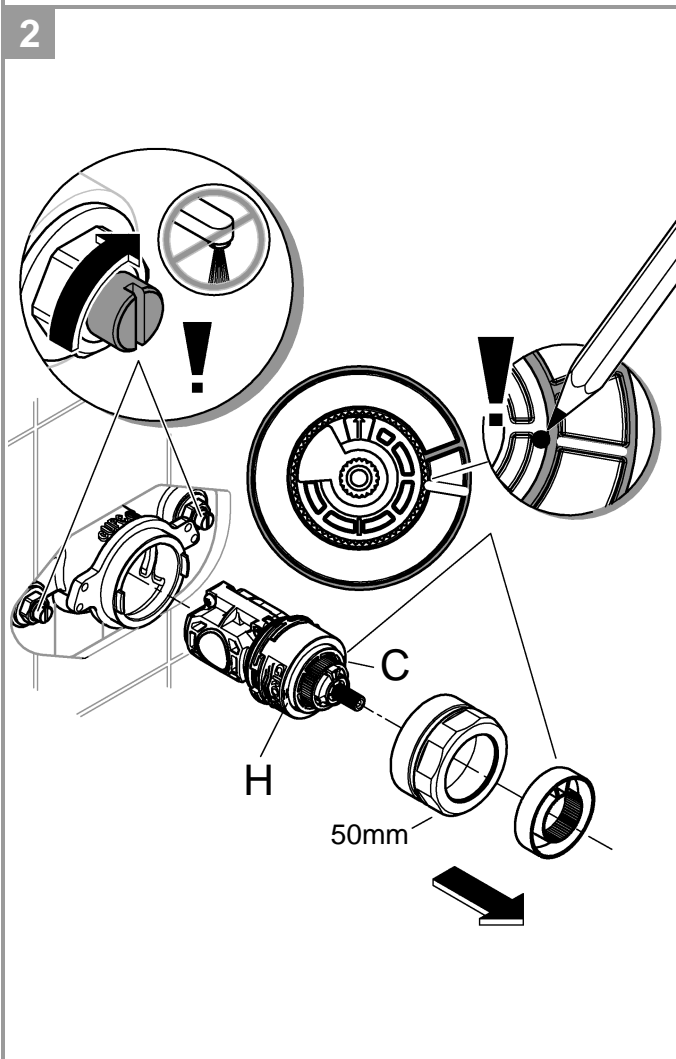
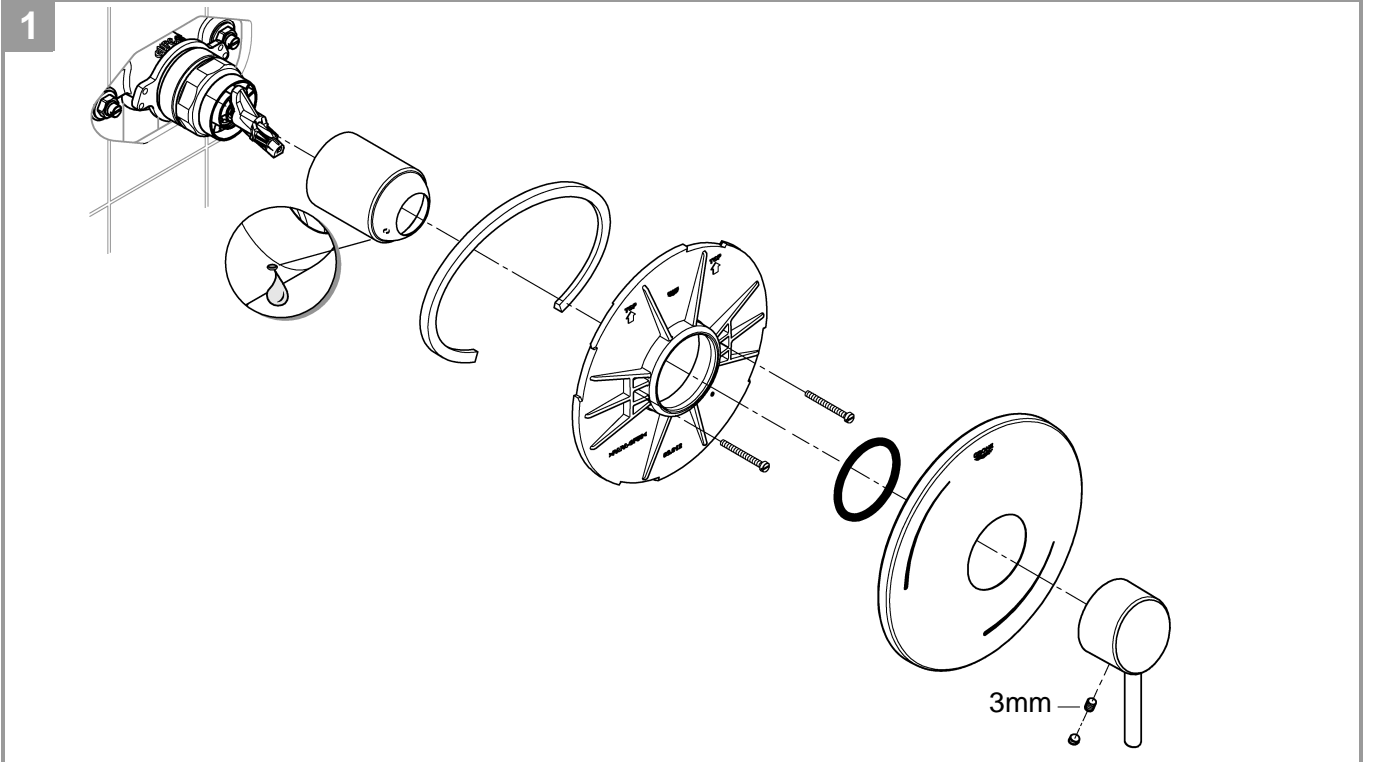

1

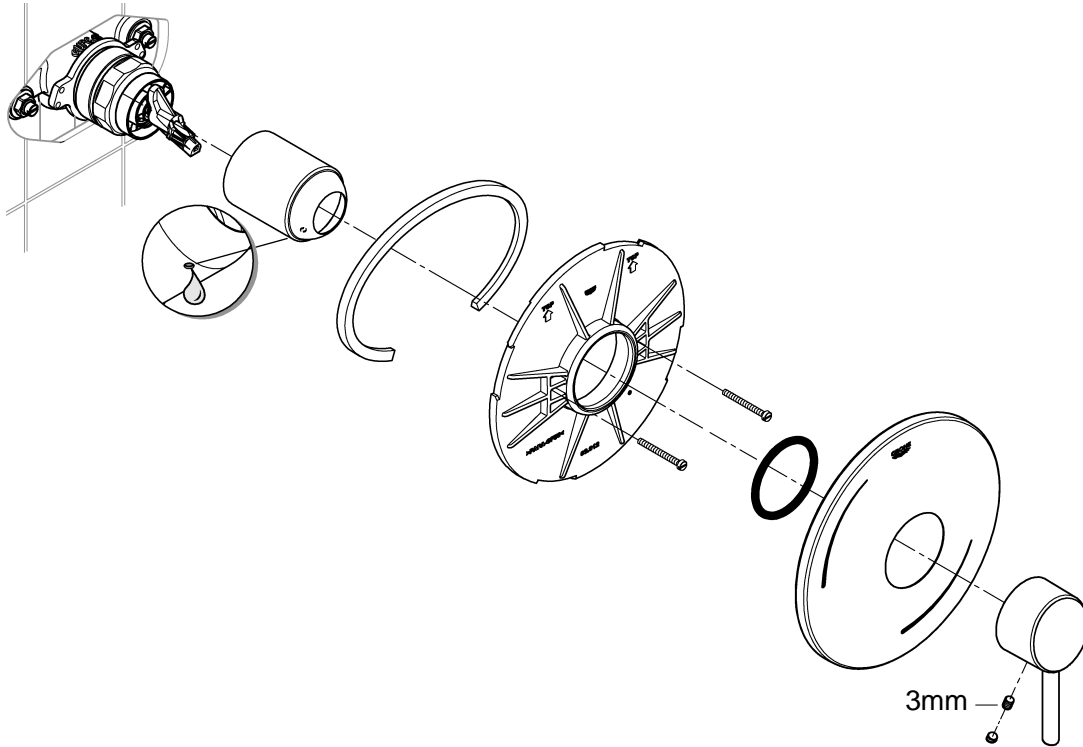

2

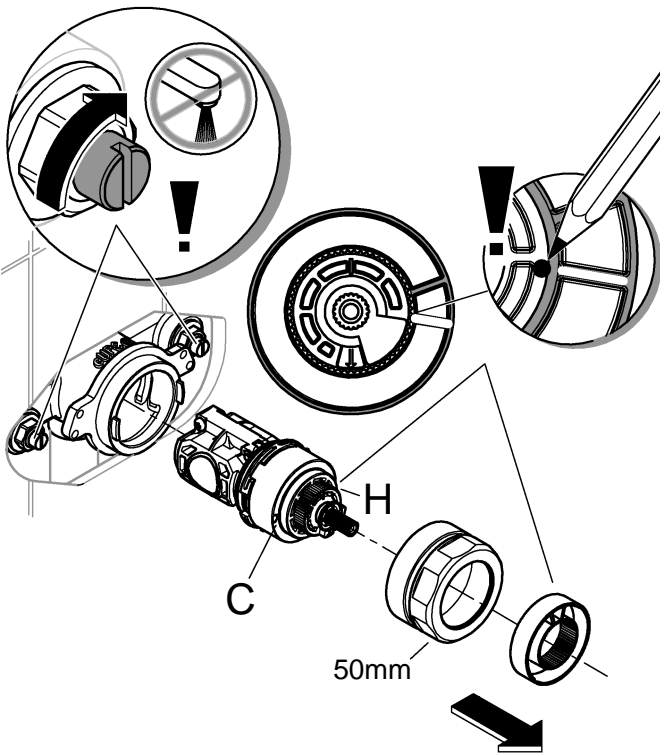

3

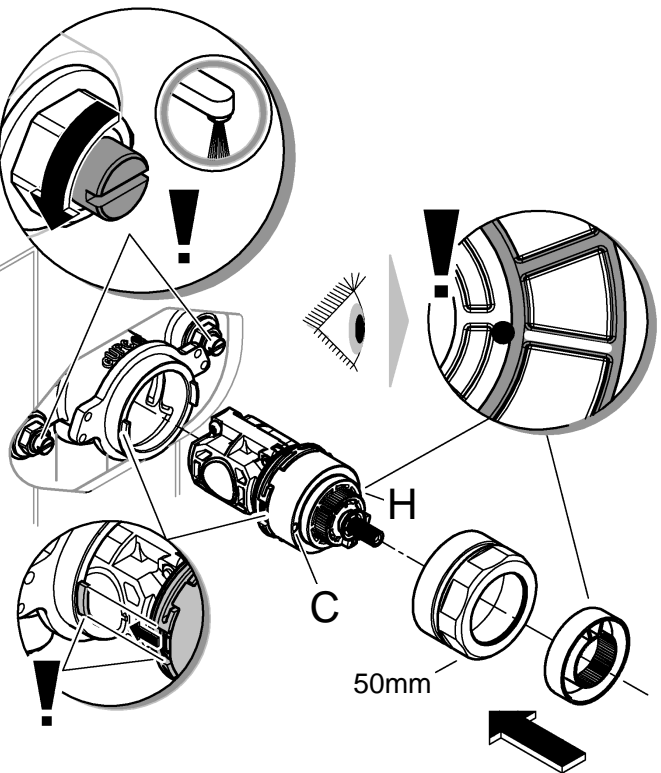



35 015

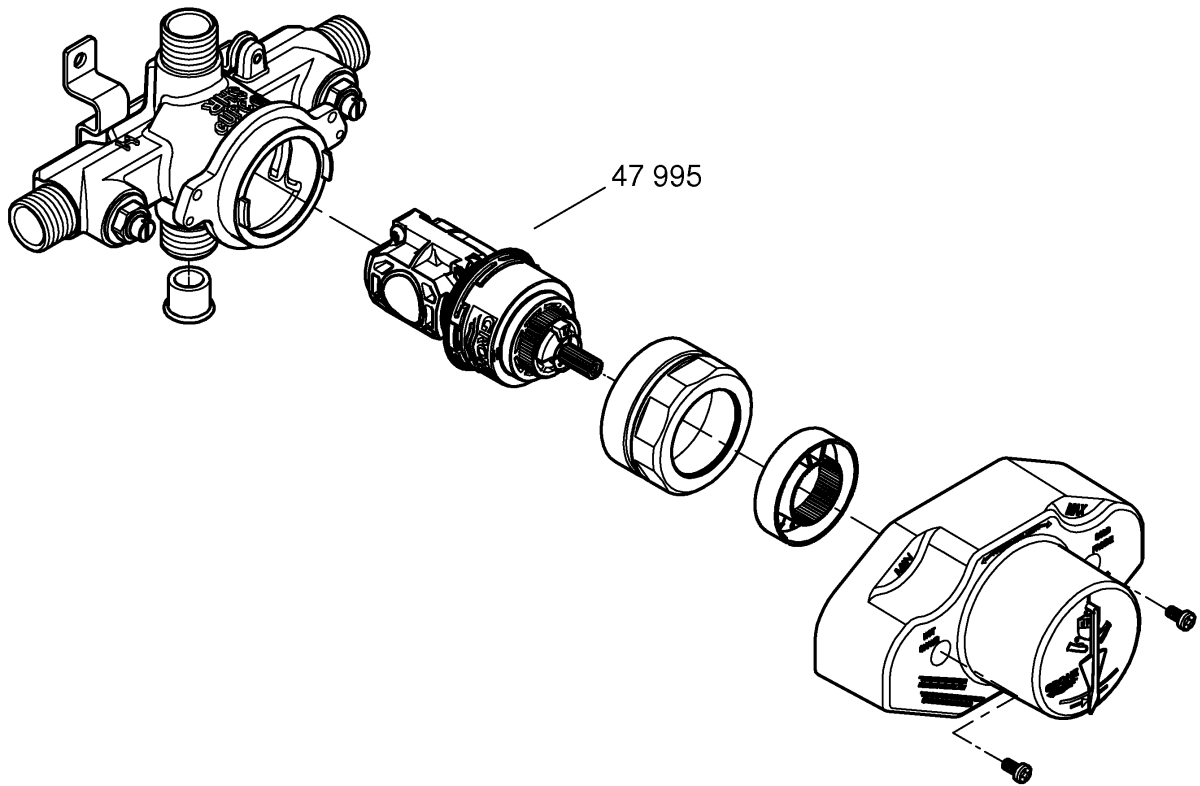

29 100

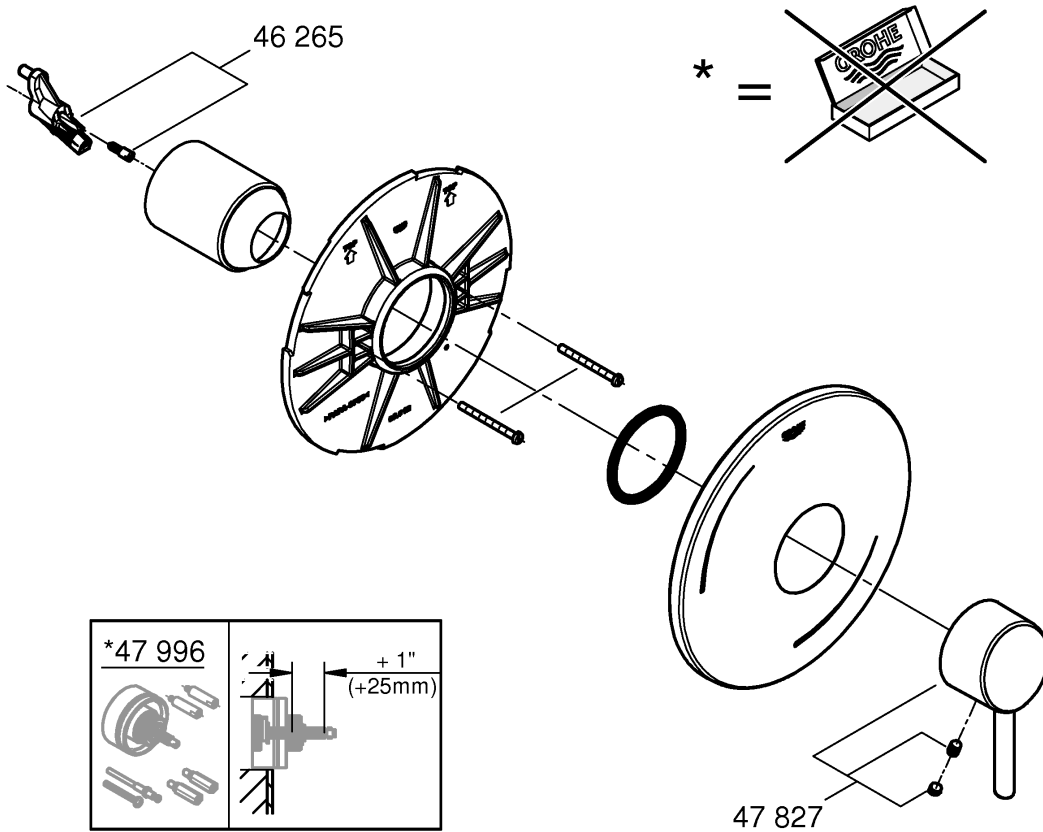

English

Flush piping system prior and after installation of faucet thoroughly!

Winterizing the system

It is recommended that the "pressure balancing cartridge" be removed from the valve casting if the system is to be shut off during the winter.

Maintenance:

Pull the pressure balancing cartridge out of the valve body noting the location of "H" and "C".

The pressure balancing cartridge must be replaced as a complete unit.

Reassemble in reverse order.

Ensure that the hot "H" and cold "C" markings are on the correct side.

Notes:

- Major pressure differences between cold and hot water supply should be avoided.
- To be installed according to local codes and regulations.

Replacement parts, see page 8 (* = special accessories).

Care

Instructions for care of this faucet will be found in the Limited Warranty supplement.

Français

Bien rincer les canalisations avant et après l'installation!

Hivernisation du système

Il est recommandé de retirer la "cartouche d'équilibrage de pression" du boîtier de robinet si le système doit être fermé pendant l'hiver.

Maintenance:

Sortir la cartouche d'équilibrage de pression du corps de robinet en notant la position des marques "H" et "C". La cartouche d'équilibrage de pression doit être remplacée en bloc.

Le remontage se fait dans l'ordre inverse.

S'assurer que les marques "H" (chaud) et "C" (froid) sont du bon côté.

Remarques:

- Il convient d'éviter toute différence de pression importante entre l'alimentation en eau chaude froide et chaude.
- A installer conformément aux prescriptions et réglementations locales.

Pièces de rechange, voir page 8 (* = accessoires spéciaux).

Entretien

Vous trouverez les instructions d'entretien de ce mitigeur dans le supplément Garantie Limitée.

Español

¡Purgar a fondo el sistema de tuberías antes y después de la instalación!

Adaptación del sistema a las condiciones invernales

Se recomienda extraer el "cartucho compensador de presión" de la carcasa de la válvula si se corta el suministro del sistema durante el invierno.

Mantenimiento:

Saque el cartucho compensador de presión existente del cuerpo de la válvula y tome nota de las posiciones de las marcas "H" y "C".

El cartucho compensador de presión constituye una unidad que debe ser cambiada de forma completa.

Para realizar el montaje, proceda siguiendo el orden inverso.

Asegúrese de que agua caliente "H" y agua fría "C" se encuentren en el lado correcto.

Notas:

- Deberán evitarse las diferencias de presión entre las acometidas del agua fría y del agua caliente.
- A ser instalado conforme a códigos y reglamentos locales.

Componentes de sustitución, véase la página 8 (* = accesorios especiales).

Cuidados periódicos

En el suplemento Garantía a Limitada encontrará las instrucciones relativas al cuidado de esta batería.

USA

& +1 800 4447643
us-customerservice@grohe.com

www.grohe.com



CDN

& +1 888 6447643
info@grohe.ca