

**Dear Customer**

Thank you for selecting our product. We are confident we can fully satisfy your expectations by offering you a wide range of technologically advanced products which directly result from our many years of experience in faucet and fitting production.

**ENGLISH**

**Estimado Cliente**

Muchas gracias por elegir nuestro producto. Estamos seguros que podemos satisfacer completamente sus expectativas ofreciéndole una amplia variedad de productos tecnológicamente avanzados que resultan directamente de muchos años de experiencia en grifos y su producción apropiada.

**ESPAÑOL**

**ATTENTION!** For care, use soft towel with soap and water only! Under no circumstances should you use any chemicals.

**ATENCIÓN!** Para el cuidado, utilice solamente una toalla suave con jabón y agua! Bajo ninguna circunstancia no use productos químicos.

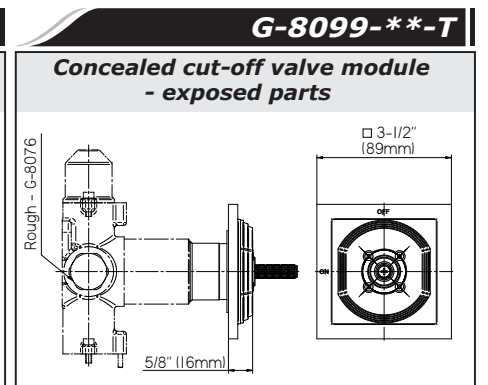
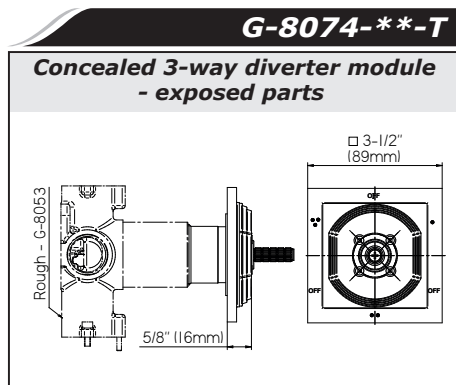
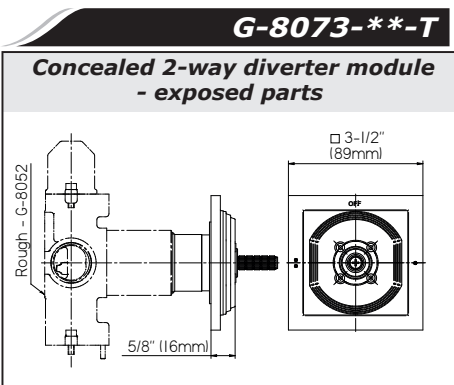
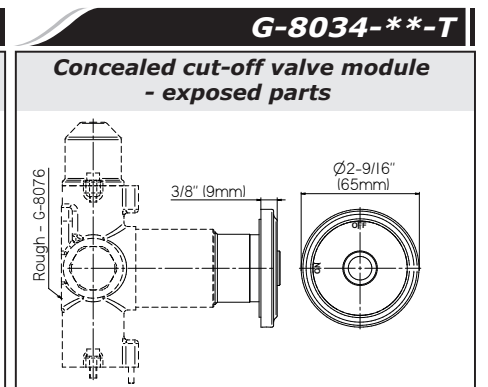
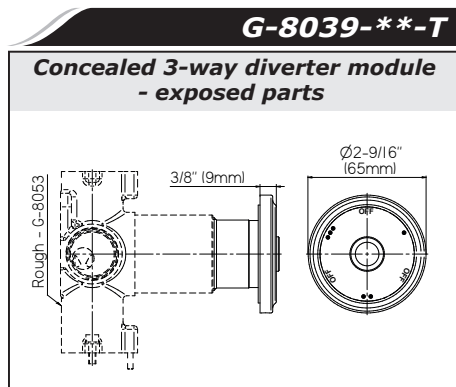
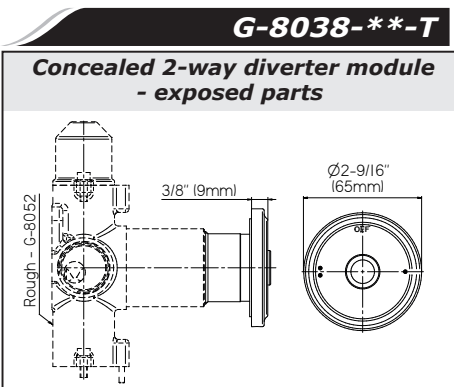
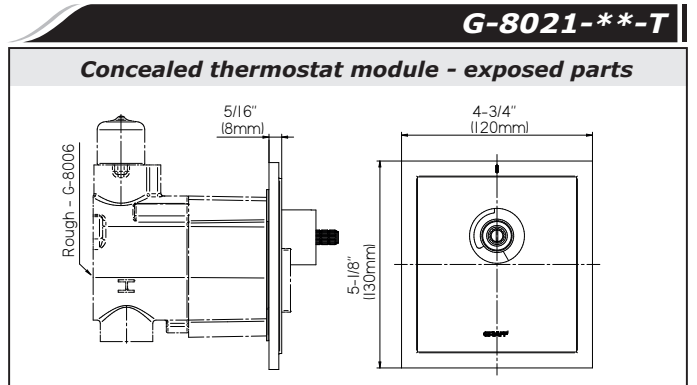
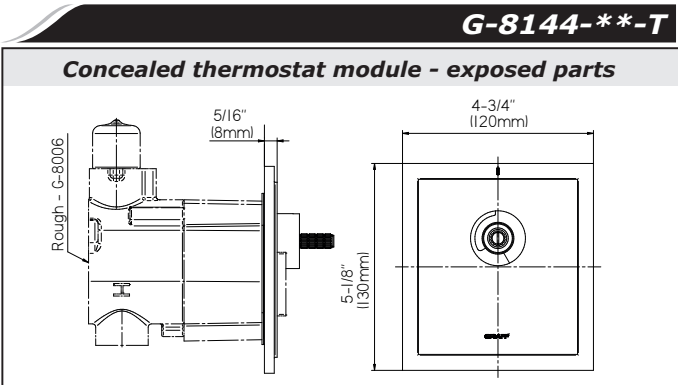
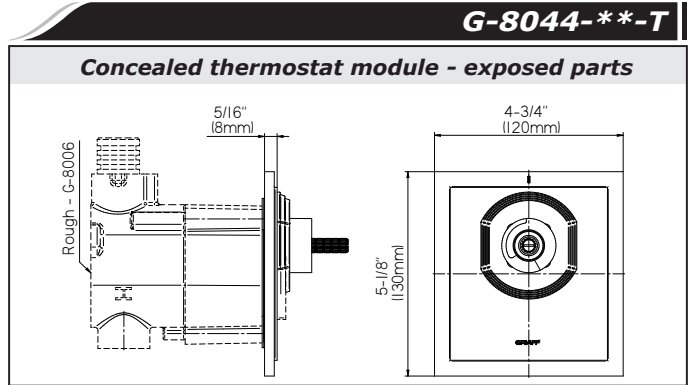
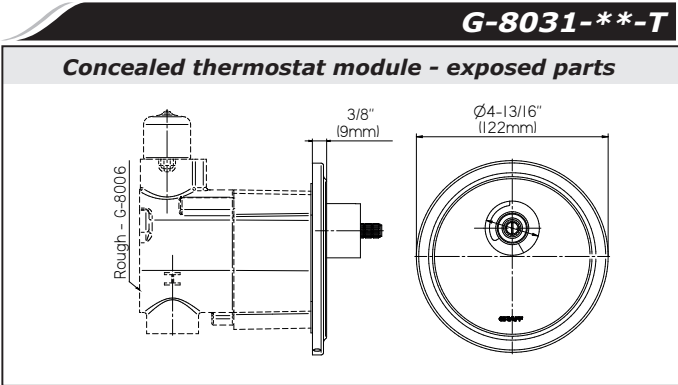

This faucet complies with NSF61/9, ASME/ANSI A112.18.1 and CSA B 125 Standards.  
Este grifo se encuentra conforme con los estándares de NSF61/9, de ASME/ANSI A112.18.1 y de CSA B 125.

Installation Instructions • Instrucciones de Instalación

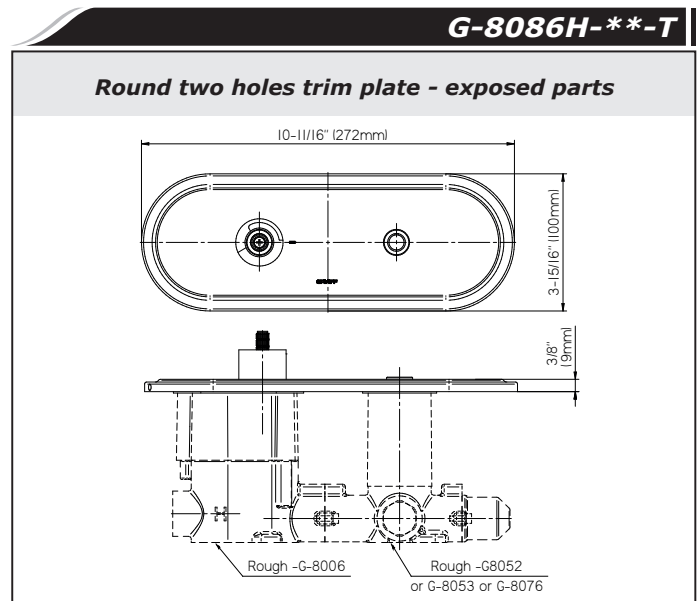
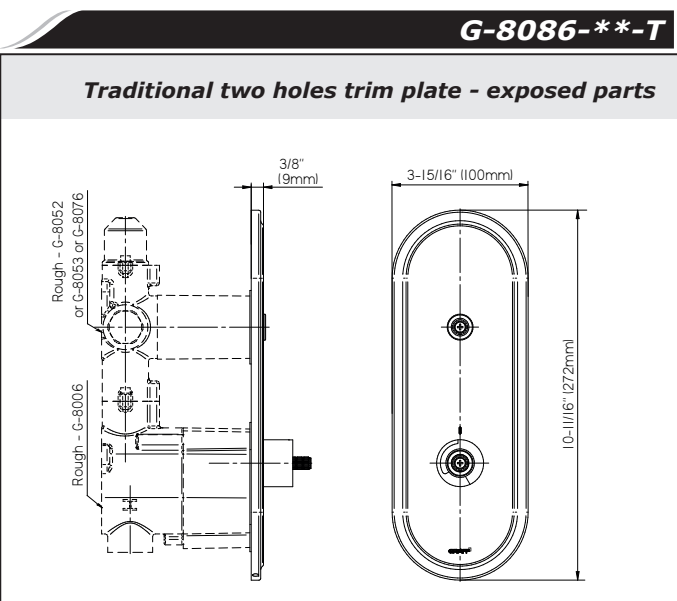
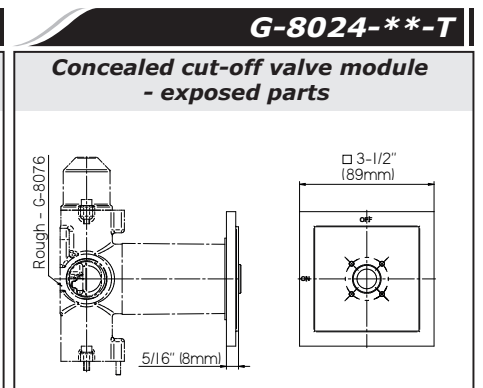
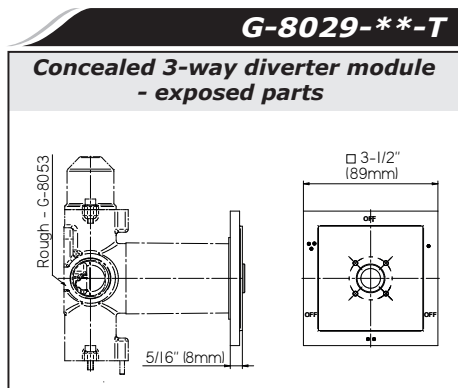
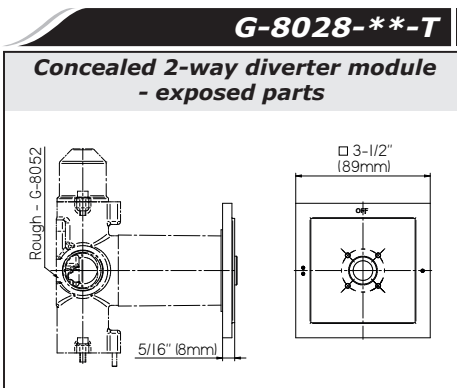
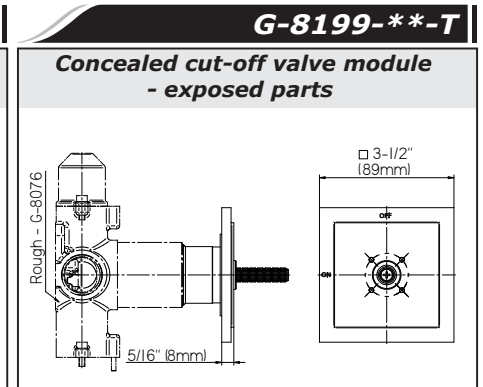
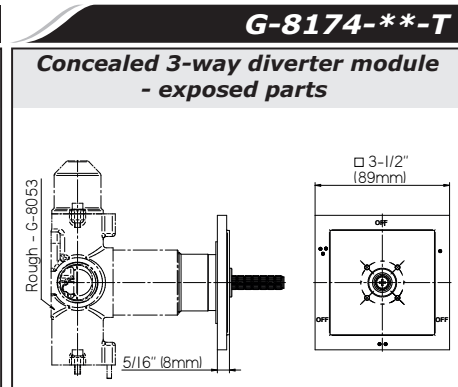
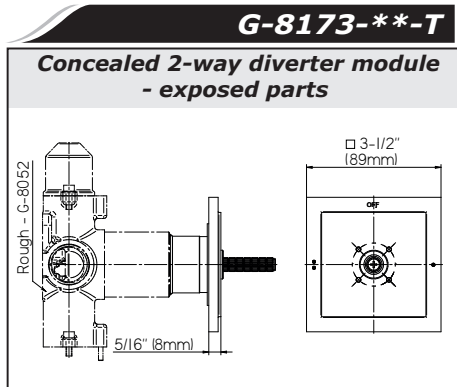

**ENGLISH**

**ESPAÑOL**

- ➔ **For easy installation of your GRAFF faucet you will need:**
- to READ ALL the instructions completely before beginning,
  - to READ ALL the warnings, care and maintenance information.
- ➔ **To complete the project, you should:**
- gather the tools and all the parts you will need,
  - prepare the mounting area,
  - connect the supply lines.

- ➔ **Para la instalación fácil de su grifo de la GRAFF usted necesitará:**
- LEER TODAS las instrucciones completamente antes de comenzar,
  - LEER TODA la información sobre las advertencias, cuidado y mantenimiento.
- ➔ **Para terminar el proyecto, usted debe:**
- recolectar las herramientas y todas las piezas que usted necesitará,
  - prepare el área para el montaje,
  - conecte las líneas de fuente.

This faucet complies with NSF61/9, ASME/ANSI A112.18.1 and CSA B 125 Standards.  
Este grifo se encuentra conforme con los estándares de NSF61/9, de ASME/ANSI A112.18.1 y de CSA B 125.

Installation Instructions • Instrucciones de Instalación

**G-8049-\*\*-T**

**Square two holes trim plate - exposed parts**

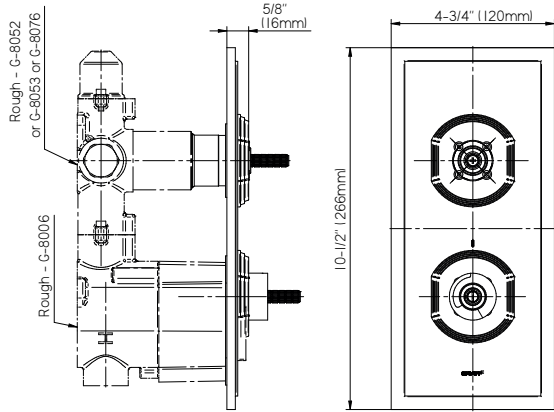

**G-8049H-\*\*-T**

**Square two holes trim plate - exposed parts**

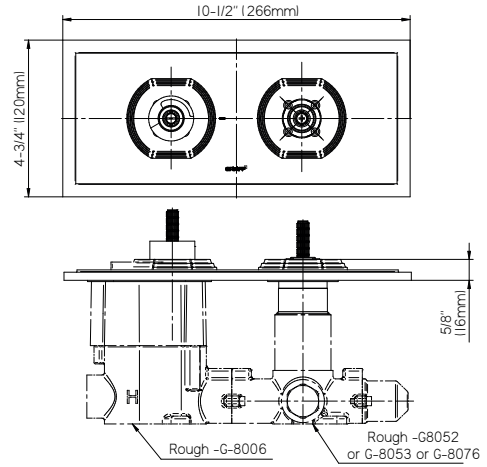

**G-8149-\*\*-T**

**Round two holes trim plate - exposed parts**

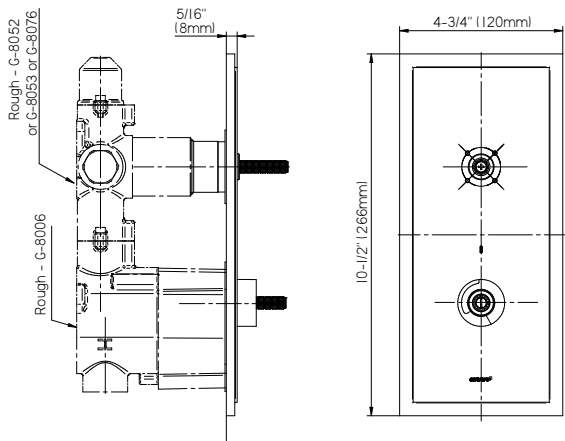

**G-8149H-\*\*-T**

**Round two holes trim plate - exposed parts**

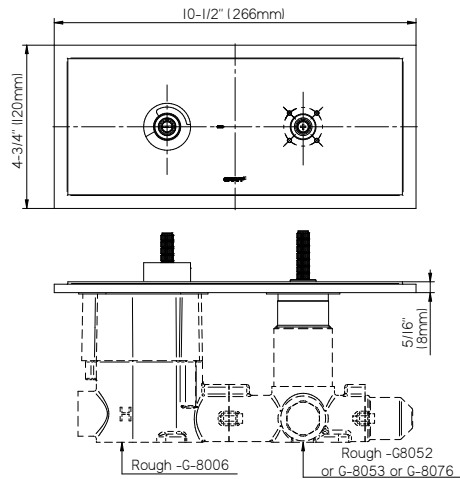

**G-8081-\*\*-T**

**Traditional two holes trim plate - exposed parts**

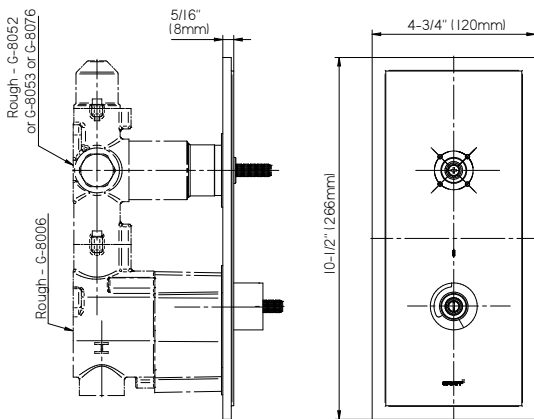

**G-8081H-\*\*-T**

**Round two holes trim plate - exposed parts**

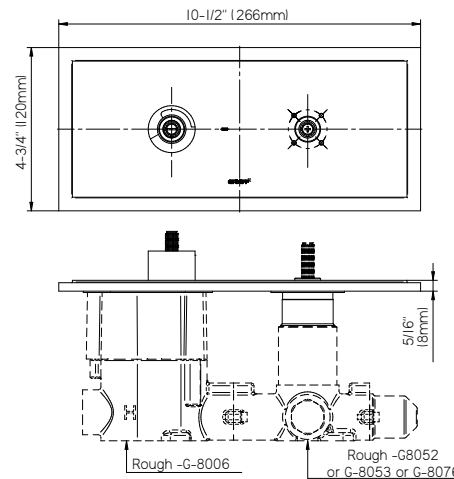

This faucet complies with NSF61/9, ASME/ANSI A112.18.1 and CSA B 125 Standards.  
Este grifo se encuentra conforme con los estándares de NSF61/9, de ASME/ANSI A112.18.1 y de CSA B 125.

Installation Instructions • Instrucciones de Instalación

**Type of Handles • Tipos de manecillas**

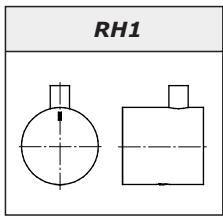
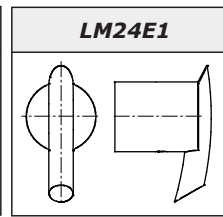
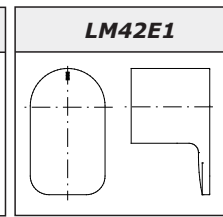
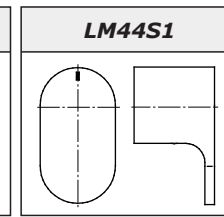
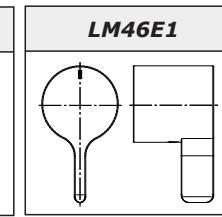
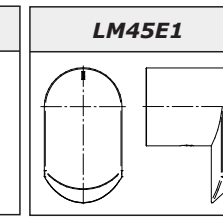
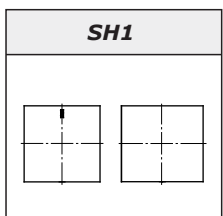
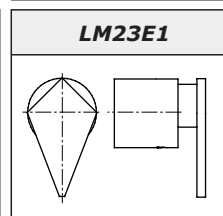
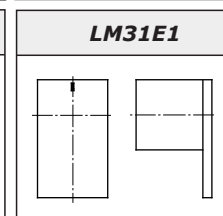
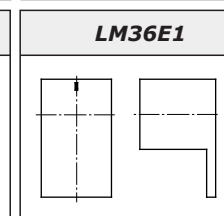
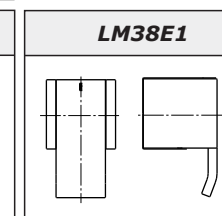
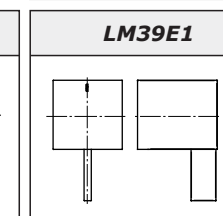
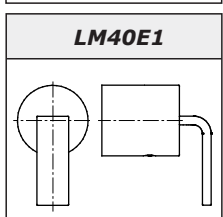
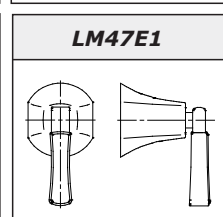
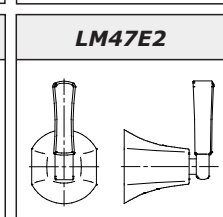
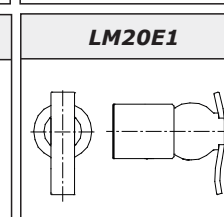
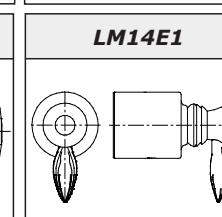
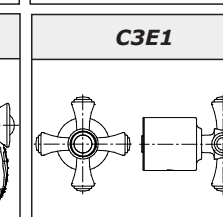
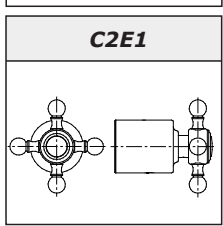
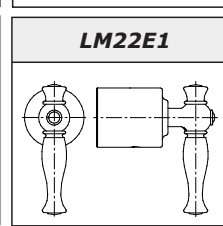
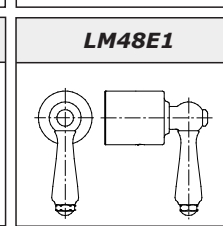
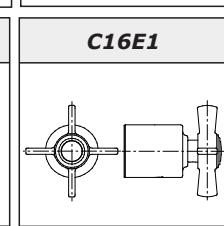
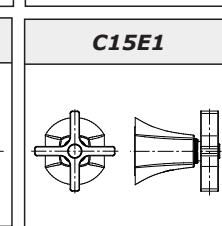
<b>RH1</b> 	<b>LM24E1</b> 	<b>LM42E1</b> 	<b>LM44S1</b> 	<b>LM46E1</b> 	<b>LM45E1</b> 
<b>SH1</b> 	<b>LM23E1</b> 	<b>LM31E1</b> 	<b>LM36E1</b> 	<b>LM38E1</b> 	<b>LM39E1</b> 
<b>LM40E1</b> 	<b>LM47E1</b> 	<b>LM47E2</b> 	<b>LM20E1</b> 	<b>LM14E1</b> 	<b>C3E1</b> 
<b>C2E1</b> 	<b>LM22E1</b> 	<b>LM48E1</b> 	<b>C16E1</b> 	<b>C15E1</b> 	

**Handles for thermostatic valves.**

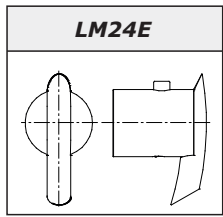
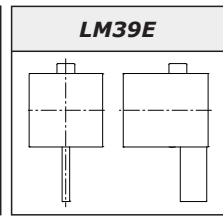
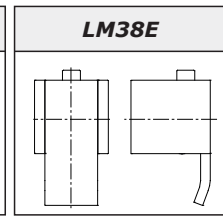
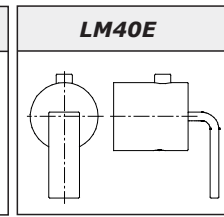
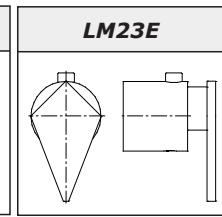
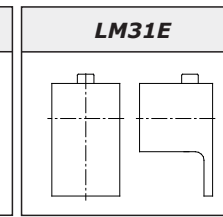
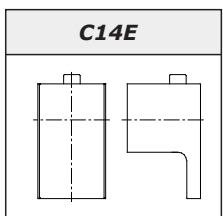
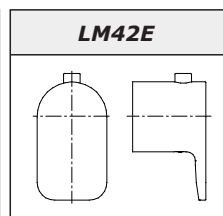
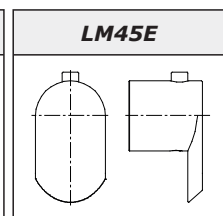
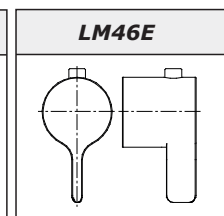
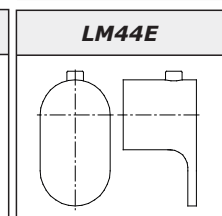
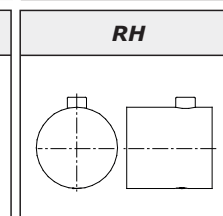
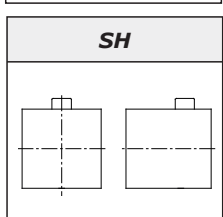
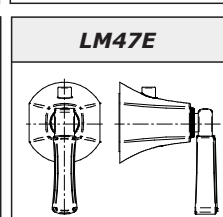
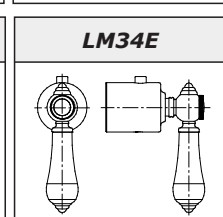
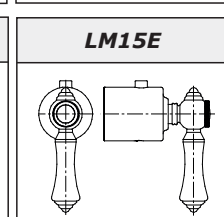
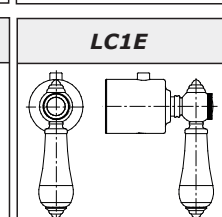
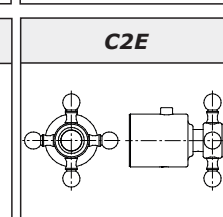
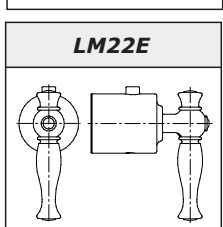
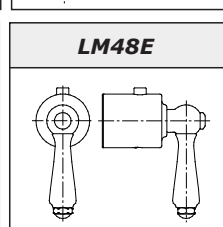
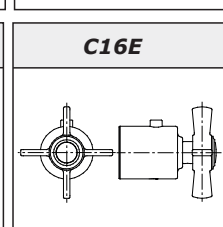
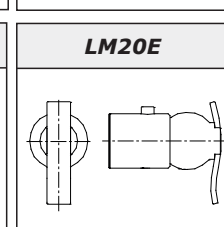
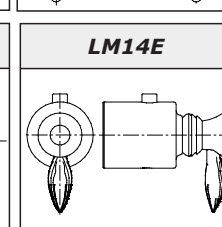
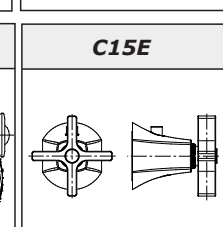
<b>LM24E</b> 	<b>LM39E</b> 	<b>LM38E</b> 	<b>LM40E</b> 	<b>LM23E</b> 	<b>LM31E</b> 
<b>C14E</b> 	<b>LM42E</b> 	<b>LM45E</b> 	<b>LM46E</b> 	<b>LM44E</b> 	<b>RH</b> 
<b>SH</b> 	<b>LM47E</b> 	<b>LM34E</b> 	<b>LM15E</b> 	<b>LC1E</b> 	<b>C2E</b> 
<b>LM22E</b> 	<b>LM48E</b> 	<b>C16E</b> 	<b>LM20E</b> 	<b>LM14E</b> 	<b>C15E</b> 

This faucet complies with NSF61/9, ASME/ANSI A112.18.1 and CSA B 125 Standards.  
Este grifo se encuentra conforme con los estándares de NSF61/9, de ASME/ANSI A112.18.1 y de CSA B 125.

Installation Instructions • Instrucciones de Instalación

ENGLISH

ESPAÑOL

<b>1</b>	HANDLE (FOR THE THERMOSTATIC VALVE)	MANECILLA (PARA LA VÁLVULA TERMOSTÁTICA)
<b>2</b>	HANDLE (FOR THE EMBEDDED VALVE)	MANECILLA (PARA LA VÁLVULA INCORPORADA)
<b>3</b>	THERMOSTATIC VALVE ROSETTE	ROSETA DE LA VÁLVULA TERMOSTÁTICA
<b>4</b>	EMBEDDED VALVE ROSETTE	ROSETA DE LA VÁLVULA INCORPORADA
<b>5</b>	LEVER BASE (OPTIONAL)	BASE DE LA MANECILLA (OPCIONAL)
<b>6</b>	MOUNTING PLATE	CHAPA DE MONTAJE
<b>7</b>	VALVE FLANGE	BRIDA DE LA VÁLVULA
<b>8</b>	TEMPERATURE LIMITING RING	ANILLO LIMITADORE TEMPERATURA
<b>9</b>	HEAD SPINDLE ELONGATION	EXTENSIÓN DEL HUSO DE LA CABEZA
<b>10</b>	SCREW	TORNILLO
<b>11</b>	SLIDE WASHER	ARANDELA DESLIZANTE
<b>12</b>	TEFLON SLIP RING	ANILLO DE CORREDERA DE TEFLON
<b>13</b>	SCREW	TORNILLO
<b>14</b>	SCREW M4X60	TORNILLO M4X60
<b>15</b>	HOLE PLUG	OBTURADOR
<b>16</b>	SCREW	TORNILLO
<b>A</b>	2MM HEX KEY	LLAVE ALLEN 2MM
<b>B</b>	2,5MM HEX KEY	LLAVE ALLEN 2,5MM

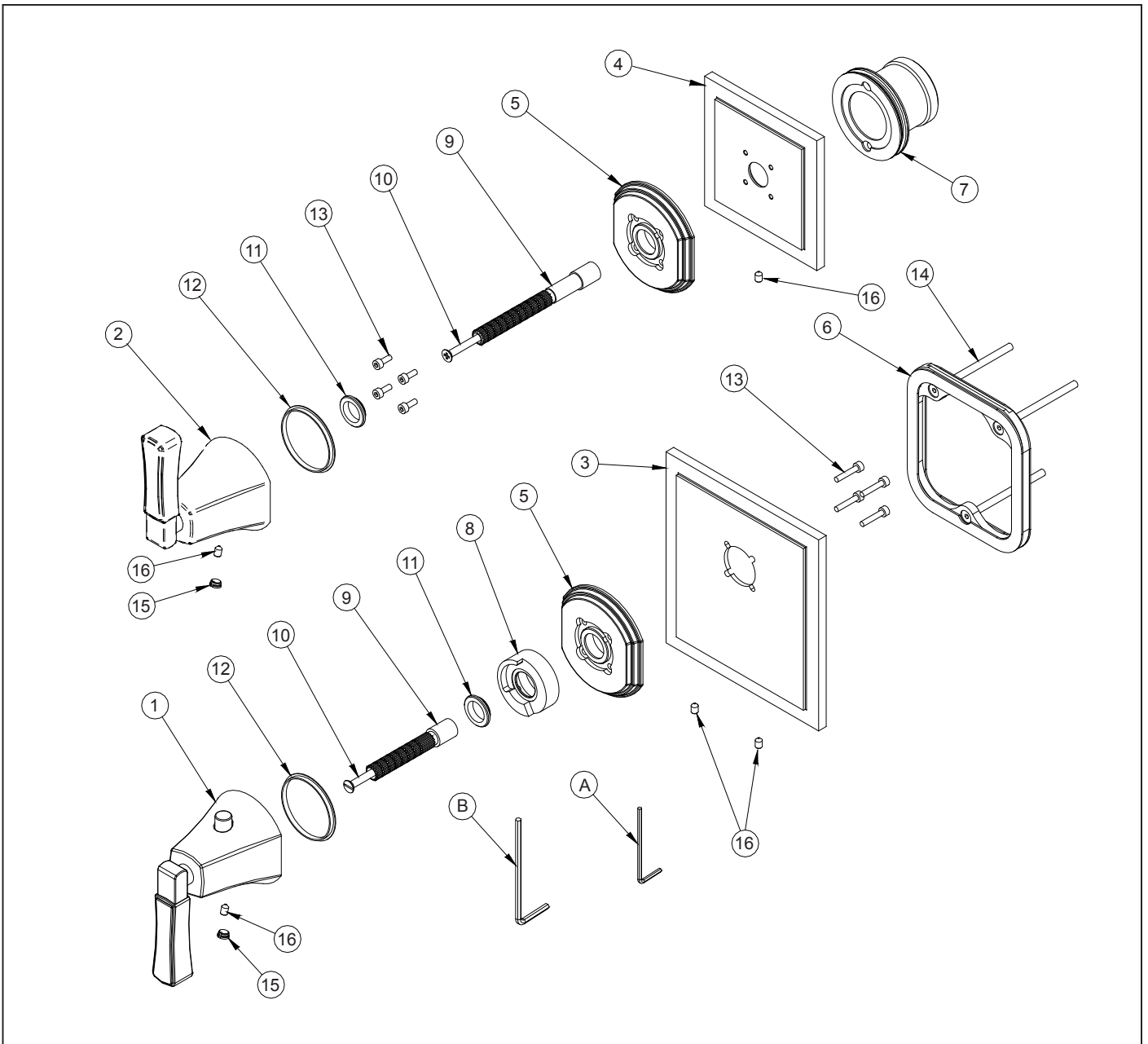

**INSTALLATION • INSTALACIÓN**

**1**

**ENGLISH**

**ESPAÑOL**

See figs. 1-8.4

Ver la fig. 1-8.4

1. Precisely cut off the installation covers (fig. 2).
2. Unscrew 3 screws (**T1**) from the thermostatic valve cover. Keeping them in their place, screw in the screws (**14**) for mounting the thermostatic valve plate (**6**). Use a hex key (**B**) for this purpose. Screw mounting flange (**7**) into the valve bushing (fig. 3.1) until it stops.
3. Put an extension (**9**) on the thermostatic valve spindle according to the markings. Attach it with a screw (**10**). Do not turn the valve using the spindle! (fig. 3.2 and 3.3).
4. Put rosettes (**3**), (**4**) onto the thermostatic valve plate (**6**) and the valve mounting flange (**7**). Connect them with screws (**16**), using the hex key (**A**) (fig. 4 and 5).
5. Depending on the rosette version, the length of the valve extensions to assemble should fit the ranges shown in fig. 6.1 or 6.2.
6. Put the handle (**2**) onto standard valve extensions (**T2**).
  - If the extension is too short, it should be replaced with the longer extension supplied with the set (**9**). For that purpose, remove the handle (**2**), unscrew the screw (**T3**) and remove the extension (**T2**). To assemble the longer extension (**9**), follow the steps in reverse order (fig. 7.1 and 7.2).
  - If the extension is too long, cut it off with the screw (see fig. 8.1-8.4).
7. Put the handle (**1**), (**2**) onto the extension and connect it with a screw (**16**). Put the cap on (**15**).

1. Corta con precisión las tapas de montaje (fig.2).
2. Desenrosque los 3 tornillos (**T1**) de la tapa de la válvula termostática. En su lugar, atornille los tornillos (**14**) para montar la placa de la válvula termostática (**6**). Use una llave hexagonal (**B**) para realizar esto. Atornille una brida de montaje (**7**) en el casquillo de la válvula (fig. 3.1) hasta que se detenga.
3. Ponga una extensión (**9**) en el huso de la válvula termostática de acuerdo con las marcas. Fíjelo con un tornillo (**10**). ¡No gire la válvula usando el huso! (fig.3.2 y 3.3).
4. Ponga rosetas (**3**), (**4**) sobre la placa de la válvula termostática (**6**) y la brida de montaje de la válvula (**7**), únalas con tornillos (**16**), usando la llave hexagonal (**A**) (fig. 4 y 5).
5. Dependiendo de la versión de la roseta, la longitud de las extensiones de la válvula para montar debe encajar en los rangos mostrados en la fig. 6.1 o 6.2.
6. Ponga la manecilla (**2**) sobre las extensiones de la válvula estándar (**T2**).
  - si la extensión es demasiado corta, debe ser reemplazada con una extensión más larga suministrada con el conjunto (**9**). A tales efectos, quite la manecilla (**2**), desatornille el tornillo (**T3**) y quite la extensión (**T2**). Para montar la extensión más larga (**9**), siga los pasos en sentido contrario (fig. 7.1 y 7.2).
  - si la extensión es demasiado larga, córtela con el tornillo (ver fig. 8.1 – 8.4).
7. Ponga la manecilla (**1**), (**2**) sobre la extensión y únala con un tornillo (**16**). Ponga la tapa (**15**).

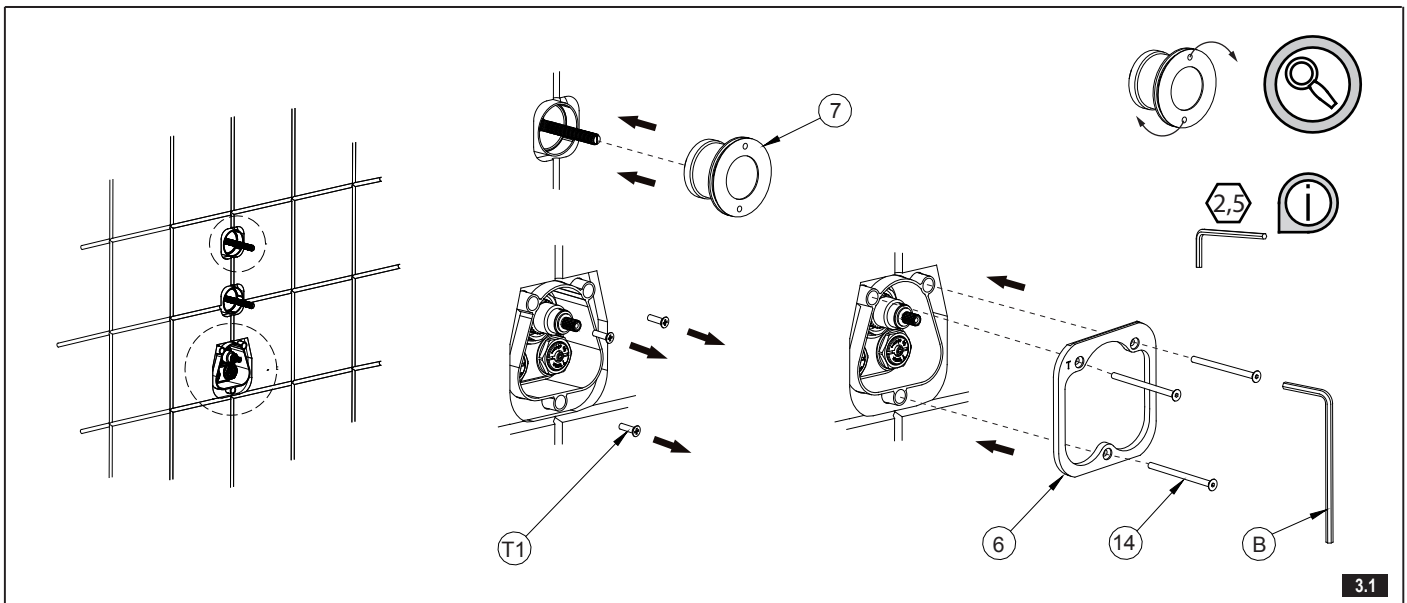
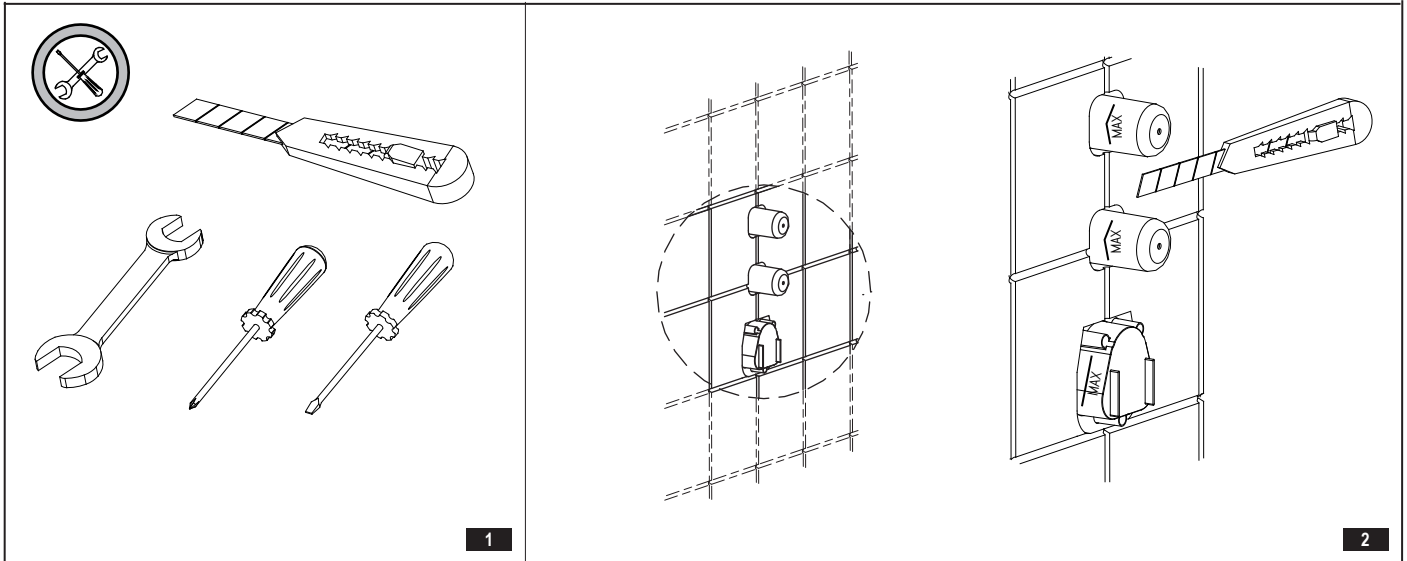

This faucet complies with NSF61/9, ASME/ANSI A112.18.1 and CSA B 125 Standards.  
Este grifo se encuentra conforme con los estándares de NSF61/9, de ASME/ANSI A112.18.1 y de CSA B 125.

Installation Instructions • Instrucciones de Instalación

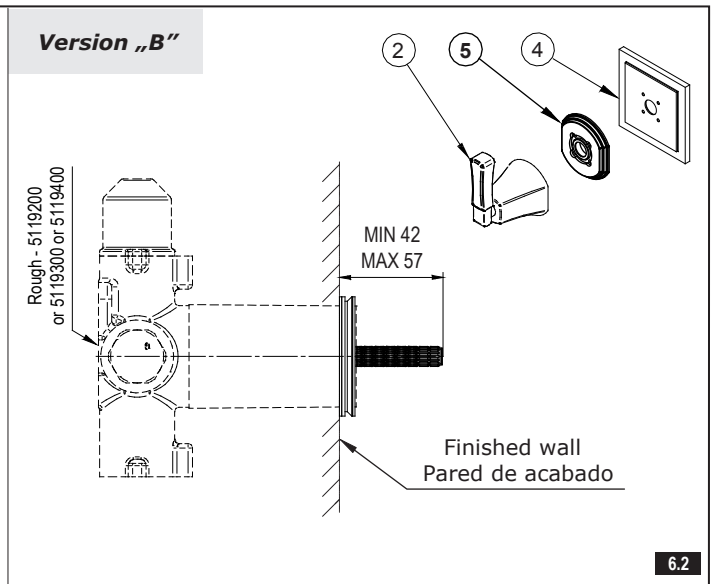
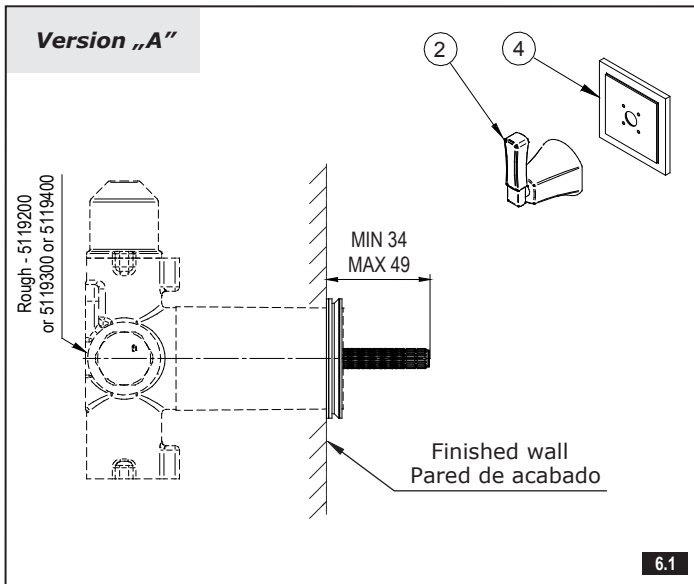
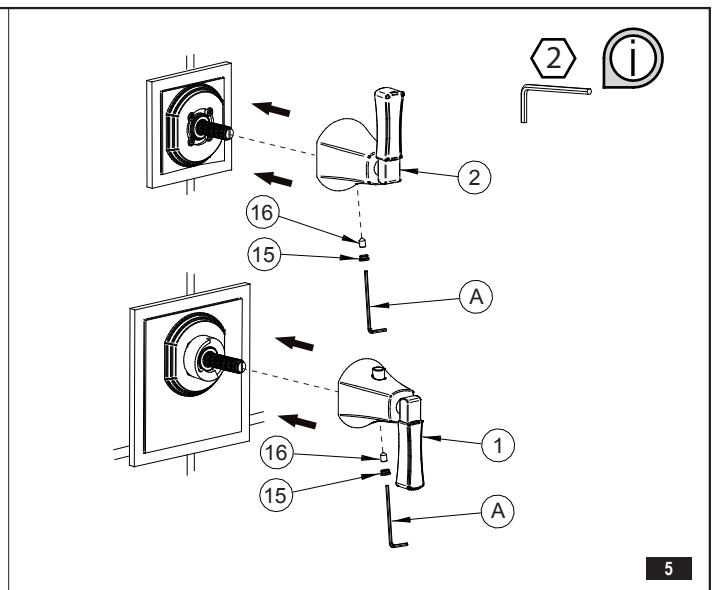
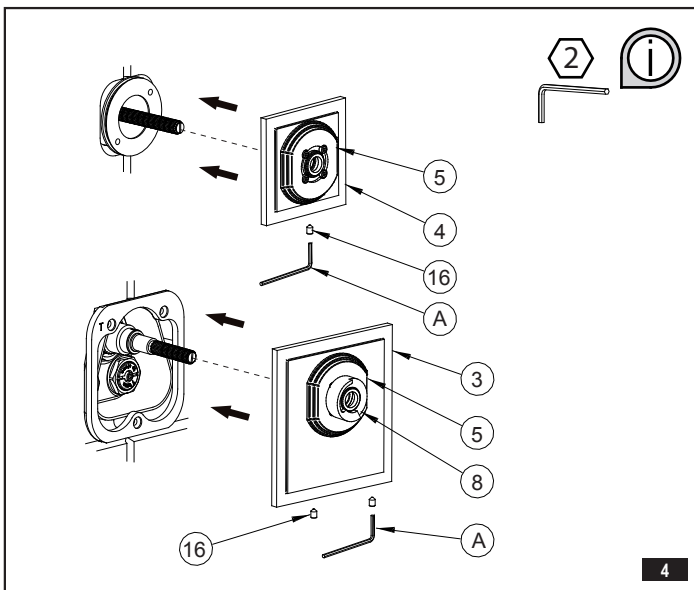
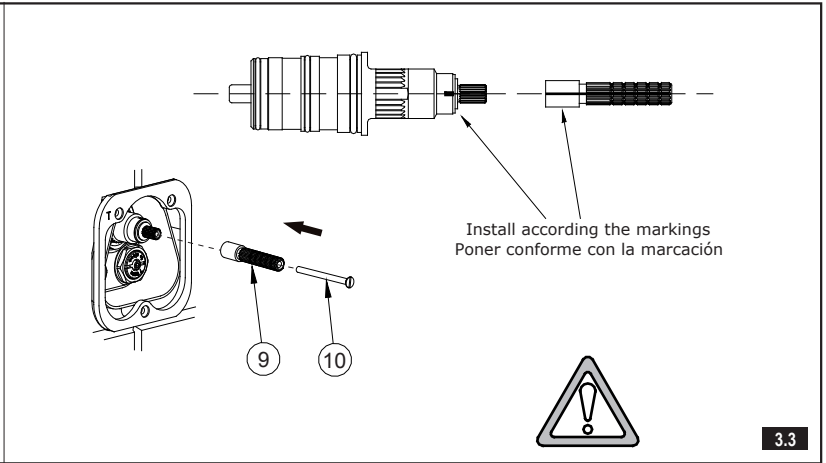
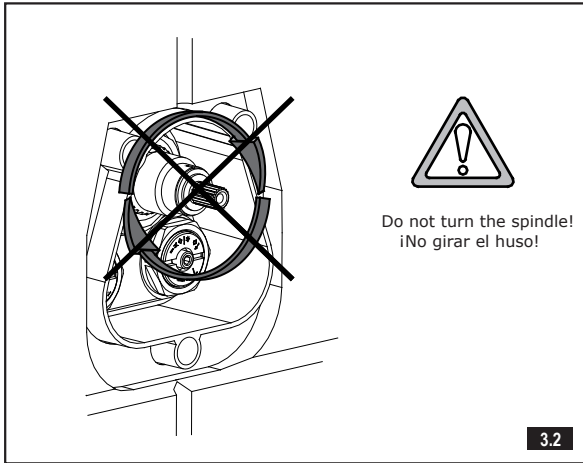

This faucet complies with NSF61/9, ASME/ANSI A112.18.1 and CSA B 125 Standards.  
Este grifo se encuentra conforme con los estándares de NSF61/9, de ASME/ANSI A112.18.1 y de CSA B 125.

Installation Instructions • Instrucciones de Instalación

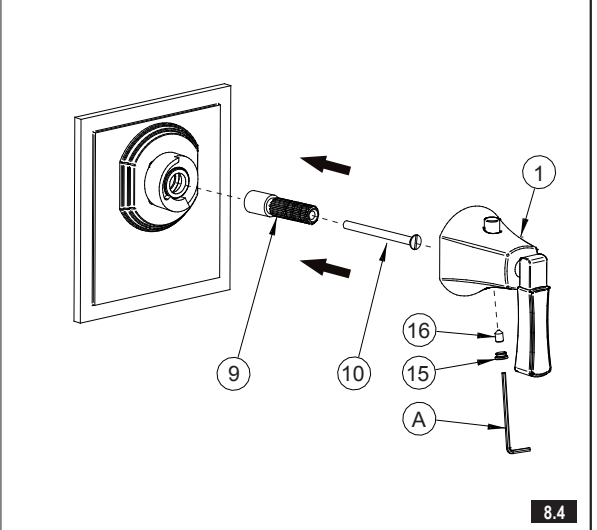
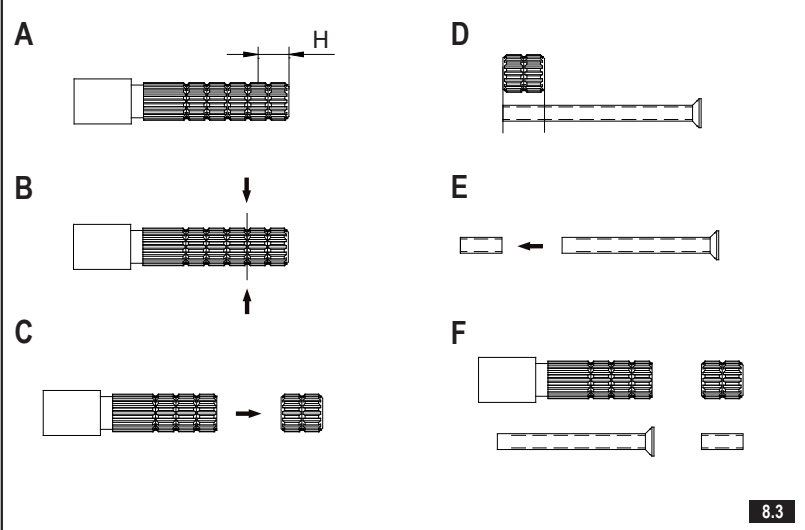
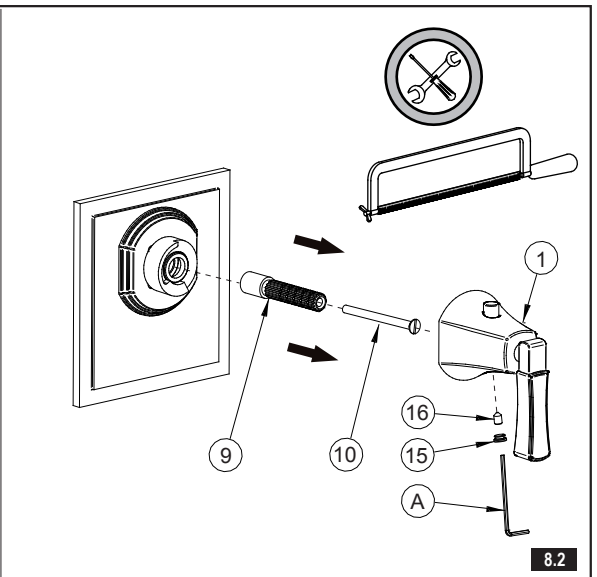
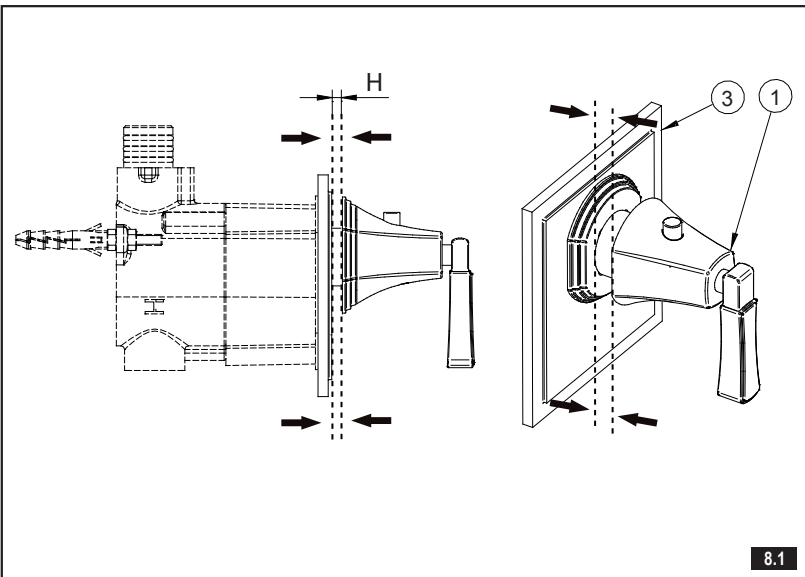
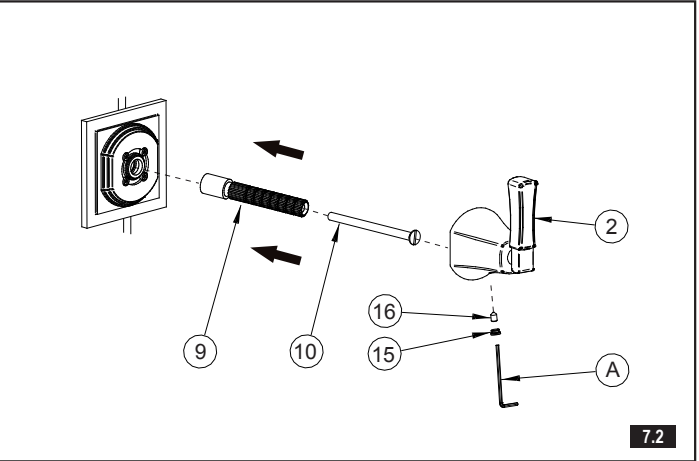
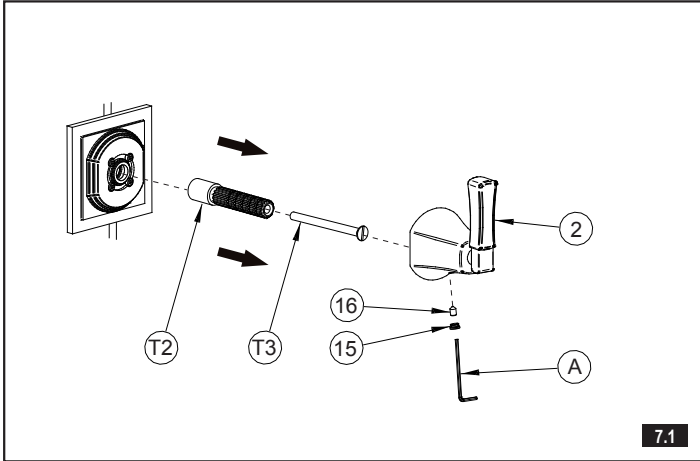



**OPERATING INSTRUCTION • INSTRUCCIÓN DE USO**

**4**

**Concealed stop/volume control valve**

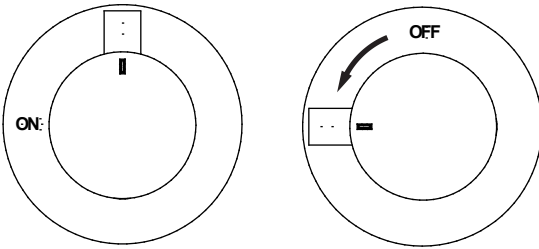

**3.1**

**ENGLISH**

The water flow is opened using the lever or the cross handle. It is opened fully by turning the lever (cross handle) in counterclockwise direction.

**ESPAÑOL**

Para abrir la salida I de ajuste de temperatura sirve la palanca o la llave cruzados. Obtenemos la apertura completa girando la palanca (la llave cruzados) en la dirección opuesta al movimiento del reloj.

**ENGLISH**

Receiver selection is made by turning the lever (handwheel) in the desired direction – to the markings on the escutcheon. Moving the lever (handwheel) to the position presented in Fig. 3.2, 3.3 will cut off the water flowvalve "closed".

**ESPAÑOL**

La selección del tipo de receptor se debe hacer girando la palanca (el volante) en las posiciones escogidas, marcadas en la roseta. Girar la palanca (el volante) a la posición conforme con la fig. 3.2, 3.3 cierra la salida del agua – la válvula en la posición "cerrada".

**Concealed 2-way diverter**

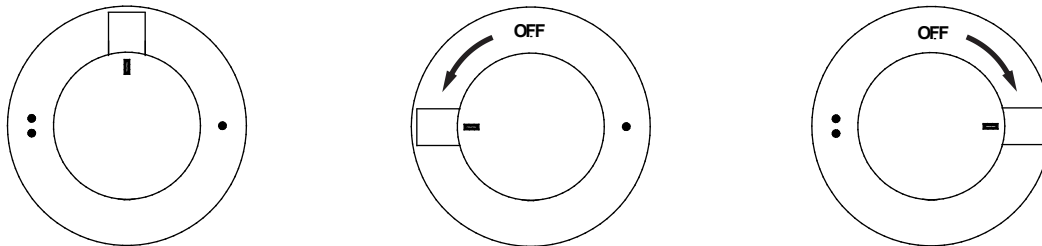

**3.2**

**Concealed 3-way diverter**

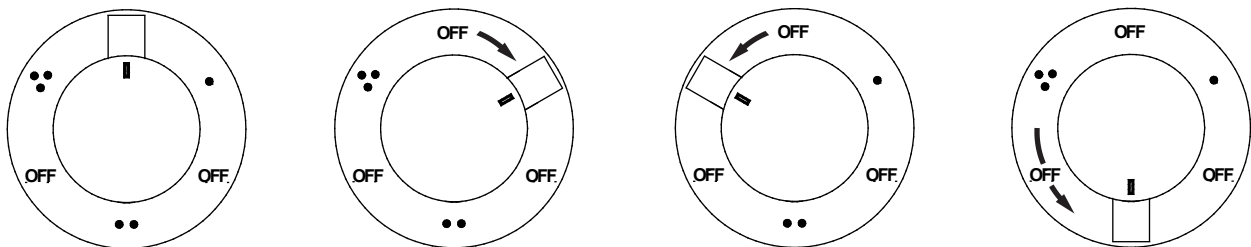

**3.2**

**CARE AND MAINTENANCE • CUIDADO Y MANTENIMIENTO**

**5**

**ENGLISH**

Your *Graff* faucet is designed and engineered in accordance with the highest quality and performance standards. Be sure not to damage the finish during installation. Care should be given to the cleaning of this product. Although its finish is extremely durable, it can be damaged by harsh abrasives or polish. **Never use abrasive cleaners, acids, solvents, etc. to clean any *Graff* product. To clean, simply wipe gently with a damp cloth and blot dry with a soft towel.**

**ESPAÑOL**

Su grifo de la *Graff* esta diseñado y dirigido acuerdo con los estándares de funcionamiento y calidad más altos. Este seguro no dañar las terminaciones del grifo durante la instalación. Cuide el producto manteniendolo siempre limpio. Aunque su acabado es extremadamente durable, puede ser dañado por los abrasivos o pulientes ásperos. **Nunca utilice limpiadores abrasivos, ácidos, solventes, el etc. para limpiar cualquier producto de la *Graff*. Para limpiar, simplemente use un paño húmedo y seque con una toalla suave.**

**WARRANTY • GARANTÍA**

**ENGLISH**

Warranty conditions and warranty registration card are outlined on a separate sheet.

**ESPAÑOL**

Las condiciones de la garantía y la tarjeta del registro de la garantía se encuentran en una pagina separada.

All dimensions and drawings are for reference only. For details, please refer to actual products.  
Todas las dimensiones y dibujos sirven únicamente de referencia. Para consultar detalles, ver los productos.