



Owner's and Installation Manual

For

Manual Transfer Switch

Models:

006852 Switch and Cord

006853 Switch, Cord and Resin Power Inlet Box

006854 Switch, Cord and Aluminum Power Inlet Box

MODEL NUMBER: _____

SERIAL NUMBER: _____

DATE PURCHASED: _____

WWW.GENERAC.COM
888-436-3722

Para español , visita: <http://www.generac.com/service-support/product-support-lookup>

Pour le français, visiter : <http://www.generac.com/service-support/product-support-lookup>

⚠ DANGER!

- ⚠ NOT INTENDED FOR USE IN CRITICAL LIFE SUPPORT APPLICATIONS.**
- ⚠ THIS PRODUCT CAN BE INSTALLED BY THE HOMEOWNER. HOWEVER, IF YOU ARE UNCOMFORTABLE WITH THE SKILLS OR TOOLS REQUIRED, HAVE A QUALIFIED ELECTRICIAN OR CONTRACTOR PERFORM THE INSTALLATION.**
- ⚠ INDOOR INSTALLATION ONLY!**

SAVE THIS MANUAL FOR FUTURE REFERENCE

Table of Contents

Safety Rules.....	Inside Front Cover
General Information	2
1.1 Introduction.....	2
1.2 Unpacking.....	2
1.3 Equipment Description	2
1.4 Transfer Switch Features	2
1.5 Specifications	2
1.6 Transfer Switch Data Decal.....	2
1.7 Panel Board Enclosure.....	2
1.8 Safe Use Of Transfer Switch.....	3
Installation.....	3
2.1 Introduction to Installation	3
2.2 Mounting.....	3
2.3 Connecting Power Source and Load Lines.....	3
2.4 Installing Power Inlet Box.....	4
2.5 Connecting Front Panel Wiring	4
2.6 Circuit Breaker Wiring	5
Operation.....	5
3.1 Manual Operation.....	5
3.2 Voltage Checks	6
3.3 Generator Tests Under Load	6
3.4 Checking Electric Operation.....	6
3.5 Installation Summary.....	7
Installation Diagram	8
Electrical Data.....	9

! SAVE THESE INSTRUCTIONS! Read the following information carefully before attempting to install, operate or service this equipment. Also read the instructions and information on tags, decals, and labels that may be affixed to the transfer switch. Replace any decal or label that is no longer legible.

! DANGER! Connection of a generator to an electrical system normally supplied by an electric utility shall be by means of suitable transfer equipment so as to isolate the electric system from utility distribution system when the generator is operating (Article 701 Legally Required Standby Systems or Article 702 Optional Standby Systems, as applicable). Failure to isolate electric system by these means may result in damage to generator and may result in injury or death to utility workers due to backfeed of electrical energy.

The manufacturer cannot anticipate every possible circumstance that might involve a hazard. The warnings in this manual, and on tags and decals affixed to the unit are, therefore, not all-inclusive. If using a procedure, work method or operating technique the manufacturer does not specifically recommend, ensure that it is safe for others. Also make sure the procedure, work method or operating technique chosen does not render the transfer switch unsafe.

Throughout this publication, and on tags and decals affixed to the generator, DANGER, WARNING, CAUTION and NOTE blocks are used to alert personnel to special instructions about a particular operation that may be hazardous if performed incorrectly or carelessly. Observe them carefully. Their definitions are as follows:

! DANGER

Indicates a hazardous situation which, if not avoided, will result in death or serious injury.

(000001)

! WARNING

California Proposition 65. Engine exhaust and some of its constituents are known to the state of California to cause cancer, birth defects, and other reproductive harm. (000004)

! WARNING

California Proposition 65. This product contains or emits chemicals known to the state of California to cause cancer, birth defects, and other reproductive harm. (000005)

WARNING

Indicates a hazardous situation which, if not avoided, could result in death or serious injury.

(000002)

CAUTION

Indicates a hazardous situation which, if not avoided, could result in minor or moderate injury.

(000003)

NOTE:

After this heading, read instructions that, if not strictly complied with, may result in damage to equipment and/or property.

These safety warnings cannot eliminate the hazards that they indicate. Common sense and strict compliance with the special instructions while performing the service are essential to preventing accidents.

Four commonly used safety symbols accompany the DANGER, WARNING and CAUTION blocks. The type of information each indicates follows:

 **This symbol points out important safety information that, if not followed, could endanger personal safety and/or property.**

 **This symbol points out potential explosion hazard.**

 **This symbol points out potential fire hazard.**

 **This symbol points out potential electrical shock hazard.**

GENERAL HAZARDS

- Any AC generator that is used for backup power if a NORMAL (UTILITY) power source failure occurs, must be isolated from the NORMAL (UTILITY) power source by means of an approved transfer switch. Failure to properly isolate the NORMAL and STANDBY power sources from each other may result in injury or death to electric utility workers, due to backfeed of electrical energy.
- Improper or unauthorized installation, operation, service or repair of the equipment is extremely dangerous and may result in death, serious personal injury, or damage to equipment and/or personal property.

- Extremely high and dangerous power voltages are present inside an installed transfer switch. Any contact with high voltage terminals, contacts or wires will result in extremely hazardous, and possibly LETHAL, electric shock. **DO NOT WORK ON THE TRANSFER SWITCH UNTIL ALL POWER VOLTAGE SUPPLIES TO THE SWITCH HAVE BEEN POSITIVELY TURNED OFF.**
- Competent, qualified personnel should install, operate and service this equipment. Adhere strictly to local, state and national electrical and building codes. When using this equipment, comply with regulations the National Electrical Code (NEC), CSA Standard; C22.1 Canadian Electric Code and Occupational Safety and Health Administration (OSHA) have established.
- Never handle any kind of electrical device while standing in water, while barefoot, or while hands or feet are wet. **DANGEROUS ELECTRICAL SHOCK MAY RESULT.**
- Remove all jewelry (such as rings, watches, bracelets, etc.) before working on this equipment.
- If work must be done on this equipment while standing on metal or concrete, place insulative mats over a dry wood platform. Work on this equipment only while standing on such insulative mats.
- Never work on this equipment while physically or mentally fatigued.
- Keep the transfer switch enclosure door closed and bolted at all times. Only qualified personnel should be permitted access to the switch interior.
- In case of an accident caused by electric shock, immediately shut down the source of electrical power. If this is not possible, attempt to free the victim from the live conductor but **AVOID DIRECT CONTACT WITH THE VICTIM.** Use a nonconducting implement, such as a dry rope or board, to free the victim from the live conductor. If the victim is unconscious, apply first aid and get immediate medical help.
- When an automatic transfer switch is installed for a standby generator set, the generator engine may crank and start at any time without warning. To avoid possible injury that might be caused by such sudden start-ups, the system's automatic start circuit must be disabled before working on or around the generator or transfer switch. Then place a "DO NOT OPERATE" tag on the transfer switch and on the generator. Remove the Negative (Neg) or (-) battery cable.
- Any voltage measurements should be performed with a meter that meets UL3111 safety standards, and meets or exceeds overvoltage class CAT III.

**For authorized service,
reference the dealer locator
number found on the cover of the
generator owner's manual.**

General Information

1.1 INTRODUCTION

This manual has been prepared especially for the purpose of familiarizing personnel with the design, application, installation, operation and servicing of the applicable equipment. Read the manual carefully and comply with all instructions. This will help to prevent accidents or damage to equipment that might otherwise be caused by carelessness, incorrect application, or improper procedures.

Every effort has been expended to make sure that the contents of this manual are both accurate and current. The manufacturer, however, reserves the right to change, alter or otherwise improve the product or manual at any time without prior notice.

1.2 UNPACKING

Carefully unpack the transfer switch. Inspect closely for any damage that might have occurred during shipment. The purchaser must file with the carrier any claims for loss or damage incurred while in transit.

Check that all packing material is completely removed from the switch prior to installation.

1.3 EQUIPMENT DESCRIPTION

The transfer switch is used for transferring critical electrical load from a UTILITY (NORMAL) power source to a GENERATOR (STANDBY) power source. The transfer switch prevents electrical feedback between two different power sources (such as the UTILITY and GENERATOR sources) and, for that reason, codes require it in all standby electric system installations.

The transfer switch consists of a transfer mechanism, a control switch, and indicator lights.

This switch is suitable for control of motors, electric discharge lamps, tungsten filament and electric heating equipment and the tungsten load does not exceed 30% of the switch rating.

This UL listed transfer switch is for use in optional standby systems only (NEC article 702).

A 50A rated switch is suitable for use on circuits capable of delivering not more than 10,000 RMS symmetrical amperes, 250 VAC maximum, when protected by a 50A maximum circuit breaker (Siemens types QP or BQ) or 50A maximum circuit breaker (Square D Q2, Westinghouse CA-CAH, General Electric TQ2 and Siemens QJ2).

1.4 TRANSFER SWITCH FEATURES

- Utilizes standard Siemens (Murray) components
- UL listed to U.S.A. and Canadian safety standards
- Single panels are compatible with single-phase generators rated up to 50 Amps/12 kW
- Flush or Surface Mount NEMA 1 indoor enclosure

Figure 1.1 — Panelboard

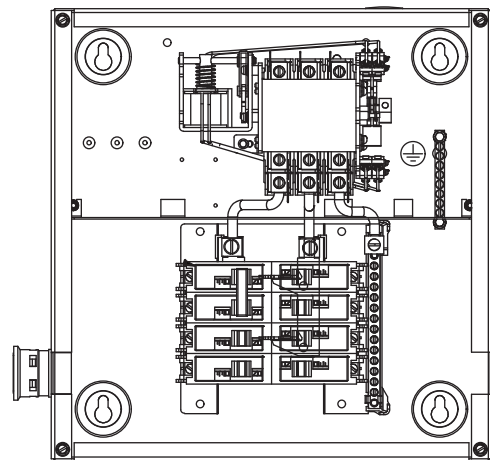

000102

1.5 SPECIFICATIONS

1.5.1 LOAD CENTER

Enclosure.....	NEMA Type 1, Surface or Flush Mount, general purpose, painted metal, for interior use only
Transfer Switch	50 Amp
Transfer Switch Wire Size	# 2 to 1/0 Cu, 1/0-2/0 Al
Ground Lug	#12 - 2/0
Neutral Bar	#4 - 14 AWG
Ground Fault or Arc Fault Circuit Breaker.....	QPF or QAF Siemens
Withstand rating Main bus (amps)	10,000
Meets NEC wire bending space	Yes
UL listed and CSA	Yes
Weight (with whip)	23 lbs (10.5 kg)
Operating temperature range	-20° F to 140° F

1.6 TRANSFER SWITCH DATA DECAL

A data decal is permanently affixed to the transfer switch enclosure. Use this transfer switch only within the specific limits shown on the data decal and on other decals and labels that may be affixed to the switch. This will prevent damage to equipment and property.

When requesting information or ordering parts for this equipment, make sure to include all information from the data decal.

Record the Model and Serial numbers in the space provided on the cover of this manual for future reference.

1.7 PANELBOARD ENCLOSURE

The standard switch enclosure is a National Electrical Manufacturer's Association (NEMA) UL Type 1 indoor enclosure.

1.8 SAFE USE OF TRANSFER SWITCH

Before installing, operating or servicing this equipment, read the SAFETY RULES (inside front cover) carefully. Comply strictly with all SAFETY RULES to prevent accidents and/or damage to the equipment. The manufacturer recommends that a copy of the SAFETY RULES are posted near the transfer switch. Also, be sure to read all instructions and information found on tags, labels and decals affixed to the equipment.

The publications that outline the safe use of transfer switches are the following:

- NFPA 70, National Electrical Code
- NFPA 70E, Standard for Electrical Safety in the Workplace
- UL 1008, Standard for Safety - Automatic Transfer Switches
- UL 67, Standard for Safety - Panelboard

NOTE:

It is essential to use the latest version of any standard to ensure correct and current information.

2.1 INTRODUCTION TO INSTALLATION

This equipment has been wired and tested at the factory. Installing the switch includes the following procedures:

- Mounting the enclosure.
- Connecting power source and load leads.
- Connecting the generator start and sensing circuit.
- Testing functions.

2.2 MOUNTING

Mounting dimensions for the NEMA Type 1 Transfer switch are in this manual, enclosures are typically wall-mounted. See the "Installation Diagram" section.

CAUTION

Handle transfer switches carefully when installing. Do not drop the switch. Protect the switch against impact at all times, and against construction grit and metal chips. Never install a transfer switch that has been damaged.

Locate automatic transfer switch with built-in emergency load center in close proximity to the main distribution panel. The transfer switch can be located to the left or right of the main distribution panel. The transfer switch may be located a different distance from the main panel depending on available mounting area. Using the one (1) foot conduit connected straight across to the main panel is another option. Always adhere to local electrical codes during installation. Hold transfer switch against the mounting surface. Level the transfer switch and mark the mounting holes. Drill the appropriate size pilot holes. Mount transfer switch with built-in load center to mounting surface with appropriate fasteners.

NOTE:

Transfer switch enclosure MUST be mounted vertically as shown in Figure 2.1.

Figure 2.1 — Mount Transfer Switch

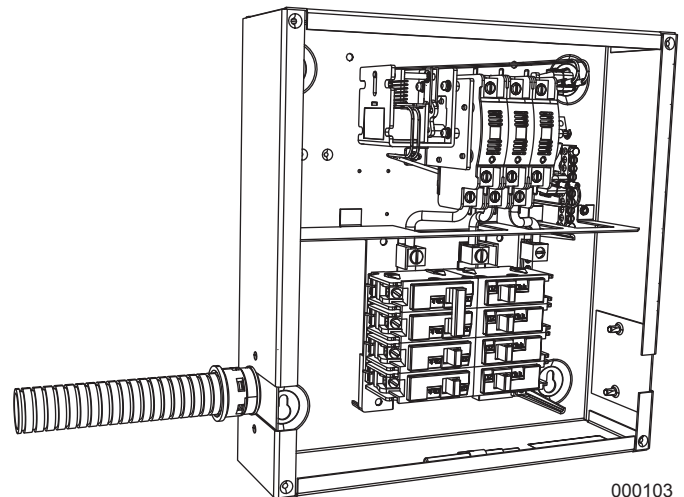

The manufacturer recommends that a licensed electrician or an individual with complete knowledge of electricity perform these procedures.

Switch service main circuit breaker to the OFF (OPEN) position prior to removal of cover or removal of any wiring of the main electrical distribution panel. The wires connected to the service main circuit breaker remain LIVE or HOT. Avoid contact with these wires and the service main circuit breaker connection lugs.

NOTE:

This switch is equipped with a 1 foot whip, with conductors and conduits sized in accordance with NEC codes.

2.3 CONNECTING POWER SOURCE AND LOAD LINES

DANGER

Make sure to turn OFF both the UTILITY (NORMAL) and EMERGENCY (GENERATOR) power supplies before trying to connect power source and load lines to the transfer switch. Supply voltages are extremely high and dangerous. Contact with such high voltage power supply lines will result in an extremely hazardous, possibly lethal, electrical shock.

Wiring diagrams and electrical schematics are provided in this manual. Power source and load connections are made at a transfer mechanism, inside the switch enclosure.

2.3.1 3-POLE MECHANISM

These switches (Figure 2.2) are used with a single-phase system, when the single-phase NEUTRAL line is to be connected to a neutral lug and is to be switched. The switched neutral provides compatibility with GFCI equipped generators.

Installation

Figure 2.2 — Typical 3-Pole Transfer Mechanism

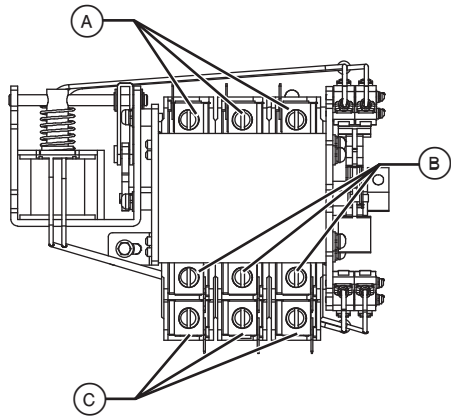

000101

- A. UTILITY LUGS (N1, N2 & N3)
- B. GENERATOR LUGS (E1, E2 & E3)
- C. LOAD LUGS (T1, T2 & T3)

Solderless, screw-type terminal lugs are standard.

Switch Rating	Wire Range	Conductor Tightening Torque
50A	1/0 - 14 AWG	50 in-lbs

Conductor sizes must be adequate to handle the maximum current to which they will be subjected to, based on the 75 °C column of tables, charts, etc. used to size conductors. The installation must comply fully with all applicable codes, standards and regulations.

Before connecting wiring cables to terminals, remove any surface oxides from the cable ends with a wire brush. All power cables should enter the switch next to transfer mechanism terminals. If aluminum conductors are used, apply corrosion inhibitor to conductors. Tighten terminal lugs to the torque values as noted on the decal located on the inside of the door. After tightening terminal lugs, carefully wipe away any excess corrosion inhibitor.

All power cables should enter the switch next to the transfer mechanism terminals.

CAUTION

- Use a torque wrench to tighten the conductors, being sure not to over tighten, or damage to the switch base could occur. If not tightened enough, a loose connection would result, causing excess heat which could damage the switch base.**

Connect power source load conductors to clearly marked transfer mechanism terminal lugs as follows:

1. Connect UTILITY (NORMAL) power source cables to switch terminals N1, N2. Connect NEUTRAL to N3.
2. Connect EMERGENCY (GENERATOR) source power cables to transfer switch terminals E1, E2. Connect NEUTRAL to E3.
3. Connect customer LOAD leads to switch terminals T1, T2. Connect NEUTRAL to T3.

Note:

The power inlet box, if not supplied in this kit, is available through Generac. You may wish to purchase special Generac cable through your dealer with control cables for easier standby generator installation/upgrades in the future.

Conductors must be properly supported, of approved insulative qualities, protected by approved conduit, and of the correct wire gauge size in accordance with applicable codes.

Be sure to maintain proper electrical clearance between live metal parts and grounded metal. Allow at least 1/2 inch for 100-400 amp circuits.

2.4 INSTALLING POWER INLET BOX

Be sure to install this Power Inlet Box (PIB) in a location that ensures that the generator is at least 5 feet away from windows, doors or other openings such as dryer vents, or air conditioning units. Hazardous fumes from generators are colorless and often odorless, and can enter your home from a variety of openings. During operation, be sure that your portable generator exhaust is away from any type of opening.

1. Remove front cover.
2. For installations where side clearance is less than 12 inches on either side, remove the three (3) screws that secure the inlet to the bottom plate. For installations where side clearance exceeds 12 inches on both sides, remove the screw that secures the bottom plate to the box.
3. Mount the power inlet box on the outside of the building in a convenient location (minimum 24 inches above grade), using the four holes provided in the back of the cabinet. Sealant should be used around the anchoring screws to keep water from entering the box at these mounting holes. Using approved wiring methods, install the wiring through one of the knockouts provided in the enclosure. Be sure to seal around the hole in the building where the conduit enters through the wall. Extend wiring inside the power inlet box approximately eight (8) inches from the point of entrance. Attach green or bare ground wire to green lead provided in power inlet box with wire nut (provided by installer).

NOTE:

The ground stud/pigtail in the non-metallic units is provided to ground metallic conduit when connecting to the non-metallic power inlet box.

4. On models WITHOUT circuit breaker, strip and insert incoming leads into terminals on power inlet. Insert white wire (neutral) into nickel plated screw terminal or white marking on the inlet. On models WITH circuit breaker, attach the incoming hot leads to the wires on the breaker with wire nuts (provided by installer).
5. Carefully fold wires into the enclosure and reattach the bottom assembly or inlet onto box with screw removed earlier.

2.5 CONNECTING FRONT PANEL WIRING

Utilize the quick disconnect connector in the wiring harness to remove the front panel during service or installation. Ensure Power and Load Lines are disconnected as described in Section 2.3 any time the front panel is removed.

2.6 CIRCUIT BREAKER WIRING

NOTE:

Balance must be maintained when moving circuit locations from main electrical distribution panel to optional standby load center. Circuit breaker positions alternate buss bars vertically. Circuits sharing a neutral wire should either be moved together to adjacent positions in emergency load center or not moved. If unsure of the proper procedure or if the installation differs from that described in this guide, consult a licensed professional at this time. Arc fault circuit breakers are available from Siemens (Murray) as required by local codes and regulations.

Remove the main electrical distribution panel cover. Remove appropriate size knockout from the side of the main panel. Remove threaded lock nut from conduit coupling. Feed all wires through knockout into main panel. Slip lock nut over wires and tighten securely onto conduit coupling.

NOTE:

Circuits to be moved must be protected by same size breaker. For example, a 15 amp 120 volt circuit in emergency load center will replace a 15 amp 120 volt circuit in main electrical distribution panel.

In the main panel, remove the black (hot) wire from the circuit breaker that protects a circuit to be powered in the event of a power failure. Wire nut the black wire to the matching circuit lead wire from the emergency circuit breaker in the load center in the transfer switch. (All circuit wires are color coded and labeled for easy identification). UL listed wire locknuts are included in installation kit. Trace each black (hot) wire connected and wire nut the white (neutral) wire from the same Romex cable (circuit) to the matching circuit number on the white (neutral) wire from the emergency load center. Repeat for each circuit. Repeat this process with the remaining circuits to be powered by the generator.

NOTE:

Both grounded and ungrounded conductors must be moved to the emergency panel and connected to the new wiring from the emergency panel using supplied wire nuts.

Install the 50 amp double pole breaker; 7 kW (purchased or supplied separately), into main electrical distribution panel. This circuit breaker must be compatible with the main electrical distribution panel. It may be necessary to reposition remaining circuit breakers or remove circuit breakers that have been disconnected to accommodate the insertion of the 50 amp double pole circuit breaker. Connect white wire to the main distribution panel neutral bar. Connect solid green wire to main electrical panel ground bar. Connect the black and red wires to the 50 amp double pole circuit breaker. Reinstall the main distribution panel cover.

3.1 MANUAL OPERATION

⚠ DANGER

⚠ Do NOT manually transfer under load. Disconnect transfer switch from all power sources by approved means, such as a main circuit breaker(s).

A manual handle is shipped with the transfer switch. Manual operation must be checked before the transfer switch is operated electrically. To check manual operation, proceed as follows:

1. Put the generator into the OFF mode.
2. Turn OFF both UTILITY and EMERGENCY power supplies to the transfer switch, with whatever means provided (such as the main line circuit breakers).
3. Note position of transfer mechanism main contacts by observing the moveable contact carrier arm.
 - Manual operation handle towards the top of switch mechanism - LOAD terminals (T1, T2) are connected to STANDBY terminals (E1, E2).
 - Manual operation handle towards the bottom of switch mechanism - LOAD terminals (T1, T2) are connected to UTILITY terminals (N1, N2).

⚠ DANGER

⚠ Always remove the manual operating handle from the transfer switch after manual operation. The manual handle may be thrown from the switch during electrical operation.

⚠ CAUTION

⚠ Do not use excessive force when operating the transfer switch manually or damage could be done to the transfer switch.

3.1.1 CLOSE TO NORMAL SOURCE SIDE

Before proceeding, verify the position of the switch by observing the position of manual operation handle in Figure 3.1. If the handle is DOWN, the contacts are closed in the NORMAL position, no further action is required. If the handle is UP, proceed with Step 1.

Step 1: With the handle inserted into the actuating shaft, move handle DOWN. Be sure to hold on to the handle as it will move quickly after the center of travel.

3.1.2 CLOSE TO EMERGENCY SOURCE SIDE

Before proceeding, verify the position of the switch by observing the position of the manual operation handle in Figure 3.1. If the handle is UP, the contacts are closed in the EMERGENCY (STANDBY) position. No further action is required. If the handle is DOWN, proceed with Step 1.

Step 1: With the handle inserted into the actuating shaft, move the handle UP. Be sure to hold on to the handle as it will move quickly after the center of travel.

3.1.3 RETURN TO NORMAL SOURCE SIDE

Manually actuate switch to return manual operating handle to the DOWN position. Remove manual handle operator from transfer switch and place in retainer clip.

Operation

Figure 3.1 — Actuating Transfer Switch

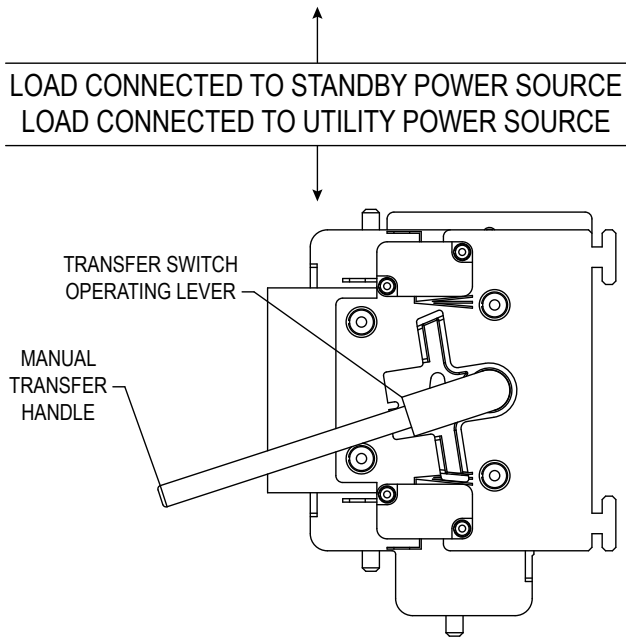

3.2 VOLTAGE CHECKS

1. Turn ON the UTILITY power supply to the transfer switch with whatever means provided (such as the UTILITY main line circuit breaker).

⚠ DANGER

⚠ Proceed with caution. The transfer switch is now electrically hot. Contact with live terminals results in extremely hazardous and possibly fatal electrical shock.

2. With an accurate AC voltmeter, check for correct voltage.
Single-phase utility supply:
Measure across ATS terminal lugs N1 and N2 (Approximately 240 VAC). Also check N1 to N3 and N2 to N3 (Approximately 120 VAC).
3. When certain that UTILITY supply voltage is correct and compatible with transfer switch ratings, turn OFF the UTILITY supply to the transfer switch.

⚠ DANGER

⚠ Confirm neutral and ground are connected at generator. Ground generator according to local codes and regulations.

4. Connect the generator to the transfer switch.

⚠ DANGER

⚠ The generator requires at least 5 feet of clearance from any opening, vent, or window of a structure.

5. Start the generator.

⚠ DANGER

⚠ Proceed with caution. Generator output voltage is now being delivered to transfer switch terminals. Contact with live terminals results in extremely dangerous and possibly fatal electrical shock.

7. With an accurate AC voltmeter and frequency meter, check the no-load, voltage and frequency.

Single-phase generator supply:

Measure across transfer switch terminal lugs E1 to E2. Also check E1 to E3 and E2 to E3.

- a. Frequency 60-62 Hertz
 - b. Terminals E1 to E2 240-246 VAC
 - c. Terminals E1 to E3 120-123 VAC
 - d. Terminals E2 to E3 120-123 VAC
8. Set the generator main circuit breaker (CB1) to OFF or OPEN position.
 9. Shut down the generator.

NOTE:

Do NOT proceed until generator AC output voltage and frequency are correct and within stated limits. If the no-load voltage is correct but no-load frequency is incorrect, the engine governed speed probably requires adjustment. If no-load frequency is correct but voltage is not, the voltage regulator may require adjustment.

3.3 GENERATOR TESTS UNDER LOAD

1. Shut down the generator.
2. Set the UTILITY SERVICE DISCONNECT circuit breaker to the OFF or OPEN position.
3. Manually actuate the transfer switch main contacts to their EMERGENCY (STANDBY) position. Refer to the "Manual Operation" section.
4. Connect the generator to the transfer switch.
5. Start the generator.
6. The generator now powers all LOAD circuits. Check generator operation under load as follows:
 - Turn ON electrical loads to the full rated wattage/amperage capacity of the generator. DO NOT OVERLOAD.
 - With maximum rated load applied, check voltage and frequency across transfer switch terminals E1 and E2. Voltage should be greater than 230 volts. Frequency should be greater than 59 Hertz.
 - Let the generator run under rated load for at least 30 minutes. With unit running, listen for unusual noises, vibration, overheating, etc., that might indicate a problem.
7. When checkout under load is complete, turn off load circuits.
8. Let the generator run at no-load for several minutes, then shut down generator.

3.4 CHECKING ELECTRIC OPERATION

To check the system for proper electrical operation, proceed as follows:

1. Ensure that the generator is OFF.
2. The six position quick connector of the electrical harness from the lights and rocker switch of the front panel needs to be

- connected to the main harness of the transfer switch. Install the front cover of the transfer switch with four (4) screws provided. See Figure 3.2.
- Turn ON the utility power supply to the transfer switch, using the means provided (such as utility main line circuit breaker). The Utility Light will illuminate only if the transfer switch is in the Generator position, and utility voltage is present.
 - Press rocker button towards Utility direction (the transfer switch will not operate without UTILITY voltage presence). The Utility Light is now off and in normal operating condition (Utility voltage is present and Transfer switch is in normal utility mode). Any loads will be energized via the power panel of the transfer switch.
 - Ensure the Generator Neutral and Ground are connected on the generator. The Generator should be properly tied to earth ground as local regulations require. Connect the generator with the Generac Portable Power Cord to the Generac Portable Inlet Box. Turn on the generator. The amber indicator light for Generator Power will illuminate on the front panel of the transfer switch any time generator voltage is available. The generator is now electrically isolated from any electrical connections beyond the transfer switch.
 - Press rocker button towards Generator Power direction. The Utility Light will illuminate to indicate utility voltage is available for transfer back to the utility. The generator light will continue to illuminate to indicate the presence of generator voltage. All loads through the transfer switch panel are now being supplied by the generator.
 - Turn off the utility power supply to the transfer switch, using the means provided (such as utility main line circuit breaker). The Utility Light will no longer be illuminated, as utility voltage is no longer present. Confirm any loads being supplied by the

- transfer switch panel are energized by the generator.
- Turn ON the utility power supply to the transfer switch, using the means provided (such as utility main line circuit breaker). The Utility Light will again illuminate.
- Press rocker button towards Utility direction. The Utility Light will turn off. The transfer switch is now in its normal operating mode. All loads from the transfer switch panel are provided by the utility.
- The generator set can be run for several minutes to cool down. The generator can be shut off. The Generator Power Light on the transfer switch will turn off.
- Disconnect the generator portable power cord.
- Store the generator as suggested by the manufacturer.
- Transfer switch testing is complete and ready for use.

Note:

The transfer switch requires electric power to operate with the rocker button. The transfer switch will not transfer to utility mode if the utility light is not illuminated prior to pressing the rocker button. The transfer switch will not transfer to generator mode if the generator light is not illuminated (this safeguards against accidental transfer to the generator if the generator power is not present).

3.5 INSTALLATION SUMMARY

- Verify installation has been properly performed as outlined by the manufacturer and that it meets all applicable laws and codes.
- Test and confirm proper operation of the system as outlined in this installation and owner's manual.
- Educate the end-user on the proper operation, maintenance and service call procedures.

Figure 3.2 — Transfer Switch Panel

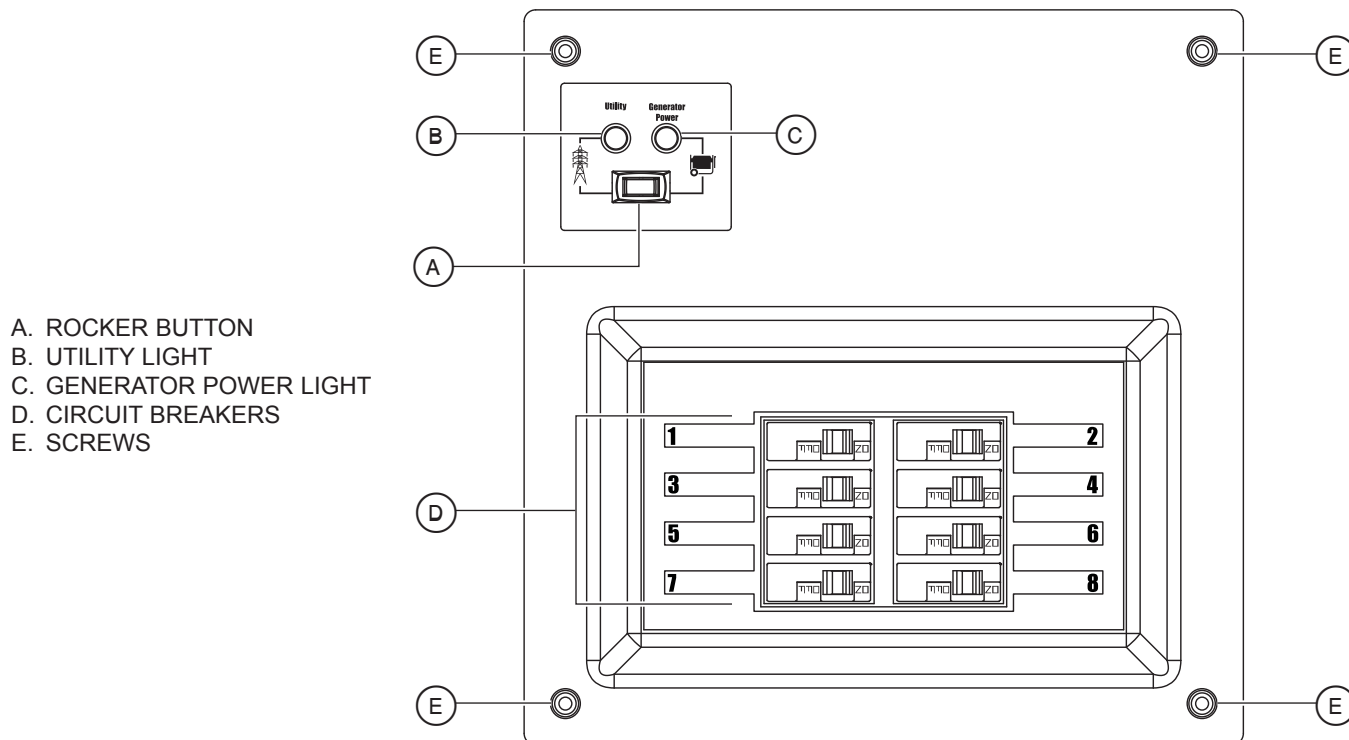

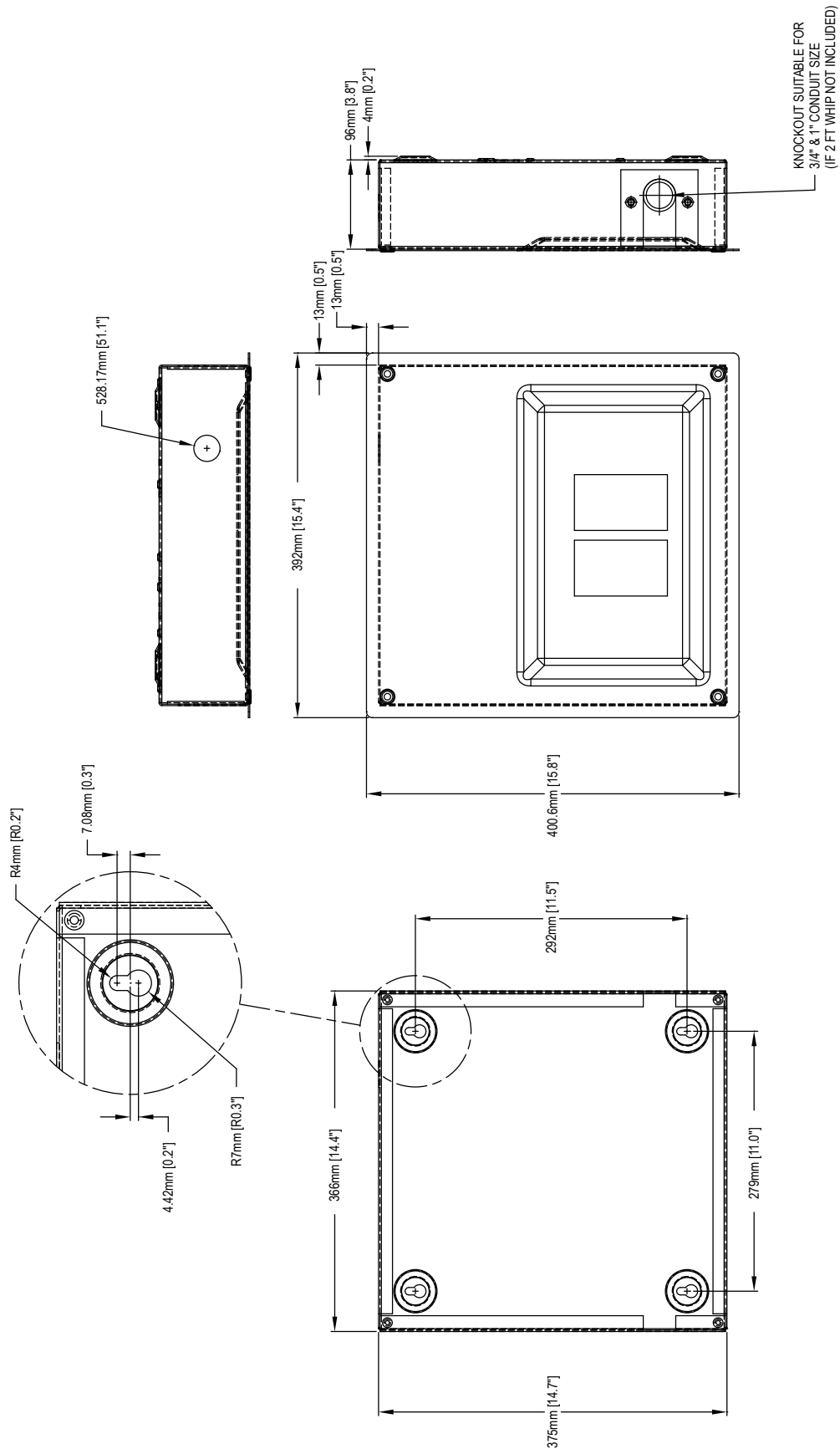

NOTE: NEUTRAL CONDUCTOR AND GROUND SHOULD BE BONDED AT PORTABLE GENERATOR. SEE GENERATOR MANUAL FOR DETAILS.

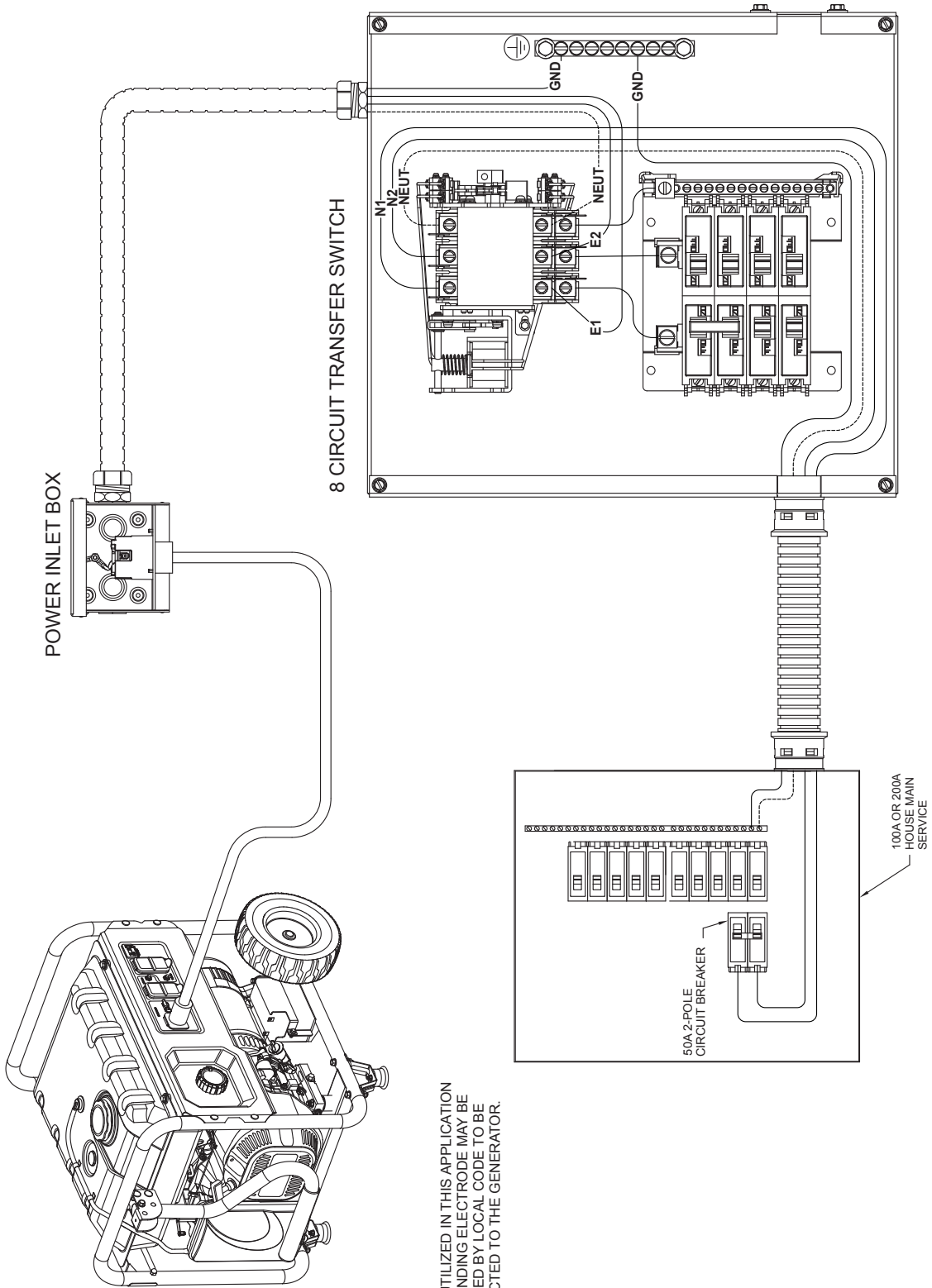

* NOTE: WHEN UTILIZED IN THIS APPLICATION A GROUNDING ELECTRODE MAY BE REQUIRED BY LOCAL CODE TO BE CONNECTED TO THE GENERATOR.

Part No. 0K9960 Rev. A 01/09/15 Printed in USA
©2015 Generac Power Systems, Inc. All rights reserved
Specifications are subject to change without notice.
No reproduction allowed in any form without prior written
consent from Generac Power Systems, Inc.



Generac Power Systems, Inc.
S45 W29290 Hwy. 59
Waukesha, WI 53189
1-888-GENERAC (1-888-436-3722)
generac.com