



FABRIC CARE
CLOSET

SAFETY INFORMATION 2

USING THE APPLIANCE
Getting Started 4

CARE AND CLEANING 20

INSTALLATION INSTRUCTIONS 22

TROUBLESHOOTING TIPS..... 30

LIMITED WARRANTY 35

CONSUMER SUPPORT 36

OWNER'S GUIDE & INSTALLATION INSTRUCTIONS

PFH18

ENGLISH/ESPAÑOL

Write the model and serial numbers here:

Model # _____

Serial # _____

They are on the label on the front of the dryer behind the door.

IMPORTANT SAFETY INFORMATION

READ ALL INSTRUCTIONS BEFORE USING THE APPLIANCE

▲ WARNING To reduce the risk of death, fire, explosion, electric shock, or injury to persons when using your appliance, follow basic precautions, including the following:

- Read all instructions before using the appliance.
- Follow all fabric care instructions and warnings to prevent melting of garments or damage to the appliance.
- **DO NOT** place clothing or items that have been previously cleaned in, washed in, soaked in or spotted with gasoline, dry-cleaning solvents, or other flammable or explosive substances, as they give off vapors that could ignite or explode.
- **DO NOT** use fabric softeners or products to eliminate static unless recommended by the manufacturer of the fabric softener or product.
- **DO NOT** use consumables unless recommended by the manufacturer of the product.
- **DO NOT** add gasoline, dry-cleaning solvents, or other flammable or explosive substances to the wash water. These substances give off vapors that could ignite or explode.
- **DO NOT** place items exposed to cooking oils in your unit. Items contaminated with cooking oils may contribute to a chemical reaction that could cause a load to catch fire.
- **DO NOT** use heat to dry articles containing foam rubber or similarly textured rubber-like materials.
- Clean the lint screen before or after each cycle.
- **DO NOT** store combustible materials, gasoline or other flammable liquids near the unit. Keep area around the air intake vent on the front of the unit and adjacent surrounding areas free from the accumulation of lint, dust and dirt.
- The interior of the appliance should be cleaned periodically by qualified service personnel.
- **DO NOT** spray any type of aerosol into, on or near the unit at any time. **DO NOT** use any type of spray cleaner when cleaning the interior. Hazardous fumes or electrical shock could occur.
- Risk of suffocation and injury from entrapment: **DO NOT** allow children to play on or in this appliance. Close supervision of children is necessary when this appliance is used near children. Before the appliance is removed from service or discarded, remove the door or lid. Failure to follow these instructions may result in death or injury to persons.
- **DO NOT** reach into the appliance if the hangers moving to prevent accidental entanglement.
- **DO NOT** install or store this appliance where it will be exposed to the weather.
- **DO NOT** tamper with controls, repair or replace any part of this appliance or attempt any servicing unless specifically recommended in the user maintenance instructions or in published user repair instructions that you understand and have the skills to carry out.
- **DO NOT** climb or stand on this unit.
- **DO NOT** operate this appliance if it is damaged, malfunctioning, partially disassembled, or has missing or broken parts including a damaged cord or plug.
- Unplug the appliance or turn off the circuit breaker before servicing. Pressing the **Power** pad **DOES NOT** disconnect power.
- See “ELECTRICAL REQUIREMENTS” located in the Installation Instructions for grounding instructions.
- **DO NOT** use replacement parts that have not been recommended by the manufacturer. (e.g. parts made at home using a 3D printer).
- **DO NOT** place hands or body near steam nozzle during operation. The steam is hot and could cause injury.
- **DO NOT** open door during operation. The performance of the product may be adversely affected. If the product is installed on or near carpet, condensation from hot air or steam may stain or damage the carpet.

READ AND SAVE THESE INSTRUCTIONS

IMPORTANT SAFETY INFORMATION
READ ALL INSTRUCTIONS BEFORE USING THE APPLIANCE

Is additional unit specific Safety needed from GEA Safety or LGE?

READ AND SAVE THESE INSTRUCTIONS

Getting started

Throughout this manual, features and appearance may vary from your model.

⚠ WARNING To reduce the risk of fire, electric shock, or injury to persons, read the **IMPORTANT SAFETY INFORMATION** before operating this appliance.

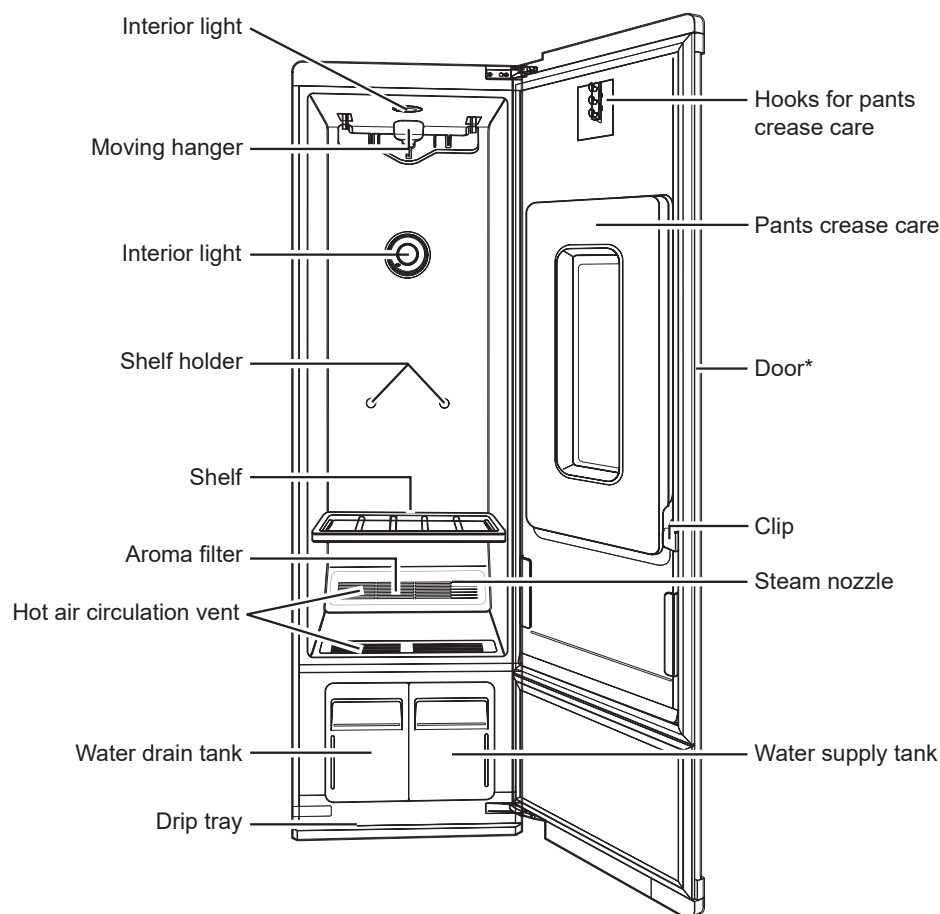

Anti-Tip Kit

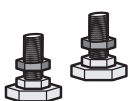

2 Rear Leveling Feet



Wrench



2 Rear Cap Covers

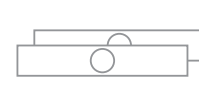

2 Hinge Covers

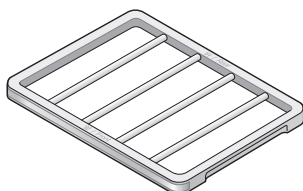

Shelf

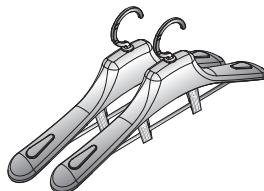

2 hangers

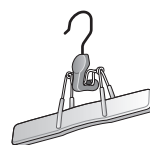

Pants hanger



Drip Tray

An ordinary metal/plastic hanger can be used if the hook is less than 5/32 in. (4 mm) thick. The hook must fit in the indentation in the moving hanger snugly. If the fit is too loose, it may result in vibration, noise, and damage to clothing.

NOTE: For your safety and for extended product life, use only authorized components. The manufacturer is not responsible for product malfunction or accidents caused by the use of separately purchased unauthorized components or parts.

*The door swing can be reversed by the installer to fit the installation location - Order part **PFA18REVV** - Door Reversing Kit - on-line at **GEApplianceparts.com** today, 24 hours a day or by phone at 877.959.8688 during normal business hours.

Getting started

Operation - Before Use

Clean the Fabric Care Closet

Clean the Fabric Care Closet thoroughly and wipe off all dust that accumulated during shipping. See **Care and Cleaning** section. Do not plug in or operate the appliance until the interior and exterior have thoroughly dried.

NOTES:

- Do not scratch the Fabric Care Closet with a sharp object or use a detergent that contains alcohol, bleach, a flammable liquid or an abrasive when removing any tape or adhesive from the Fabric Care Closet.
- Do not peel off the model or serial number label or the technical information on the rear surface of the Fabric Care Closet.
- Remove adhesive residue by wiping it off with your thumb or dish detergent.

Unpack accessories

Unpack the shelf and hangers. For instructions on installing or using accessories, see the **Loading** section.

Assemble the drip tray

Insert the drip tray at the bottom of the cabinet. See last step of **Assembling the Drip Tray** section.

Connect the power supply

Check if the power supply is connected before use.

Wash dirty clothes if necessary before putting them in the Fabric Care Closet

The Fabric Care Closet does not have a washing function. Stains and loose dirt from one item may transfer to others during a cycle. Wash or brush off dust and dirt, or spot-clean items, to avoid setting stains or transferring dirt or odors.

Getting started

Using the Fabric Care Closet

1. Prepare Items

- Wash clothes first, if needed.
- No heat-sensitive items or items that can be damaged by exposure to water. See **Choosing Fabric Care Closet-Safe Clothing** section.
- Place items on hangers or the shelf.
- Fasten buttons and close zippers to keep items on moving hangers and prevent damage.

2. Clean Lint Filter, Change Sheet In Aroma Filter

Lift out filter and remove lint from last load for faster and more efficient performance. Reinstall filter, checking alignment when closing grill. Do not operate the Fabric Care Closet without the lint filter in place. See **Checking the Lint Filter** section. If using a fabric softener sheet in the aroma filter, change it after every use. See **Changing the Aroma Sheet** section.

3. Check Water Tanks

Fill water supply tank if needed. Empty water drain tank if needed. Use clean tap water in the supply tank for better product performance and lifespan. Do not use distilled water or reuse water from the drain tank. See **Care and Cleaning** section.

4. Load Fabric Care Closet

Pay attention to fabric care labels and cycle choice. If clothing is not appropriate for the cycle selected, it may shrink or be seriously damaged. See **Loading** section. Remove all empty hangers to avoid noise, friction, and damage to clothing.

5. Turn on Fabric Care Closet

Touch the Power pad to turn on.

6. Select Cycle

Touch pad to select desired cycle and settings. See the **Cycle Guide** section.

7. Begin Cycle

Touch and hold **Start/Pause** pad to begin cycle. Pause cycle at any time by touching **Start/Pause** again. Restart cycle within four minutes of pausing it, or the Fabric Care Closet shuts off and settings are lost. Do not open door during cycle. If steam or hot air escape from open door, condensation may collect on floor or walls, resulting in damage or mold.

8. End of Cycle

Remove items when cycle finishes. Leave door open to let hot air escape. Interior light shuts off after 4 minutes if door is left open.

WiFi Connect (For customers in the United States only - on some models)

Your unit is **GE Appliances WiFi Connect** enabled.

Visit geappliances.com/connect and enter your model number to show you the proper steps to connect your appliance.

Please visit GEAppliances.com/connect to learn more about connected appliance features, to learn what connected appliance App's will work with your smartphone.

WiFi Connectivity: For assistance with the appliance or the **ConnectPlus** network connectivity, please call GE Appliances at **800.220.6899**.

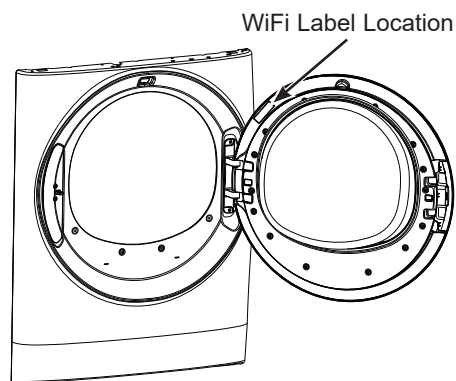

Getting started

Depending on the model, some of the following functions may not be available.

Control Panel

This unit utilizes capacitive touch. A light touch is enough to operate it. Use a cloth when cleaning the controls to avoid contacting and activating the keys. Foreign substances on the control, wearing gloves, or touching the keys through cloth may prevent the keys from activating.

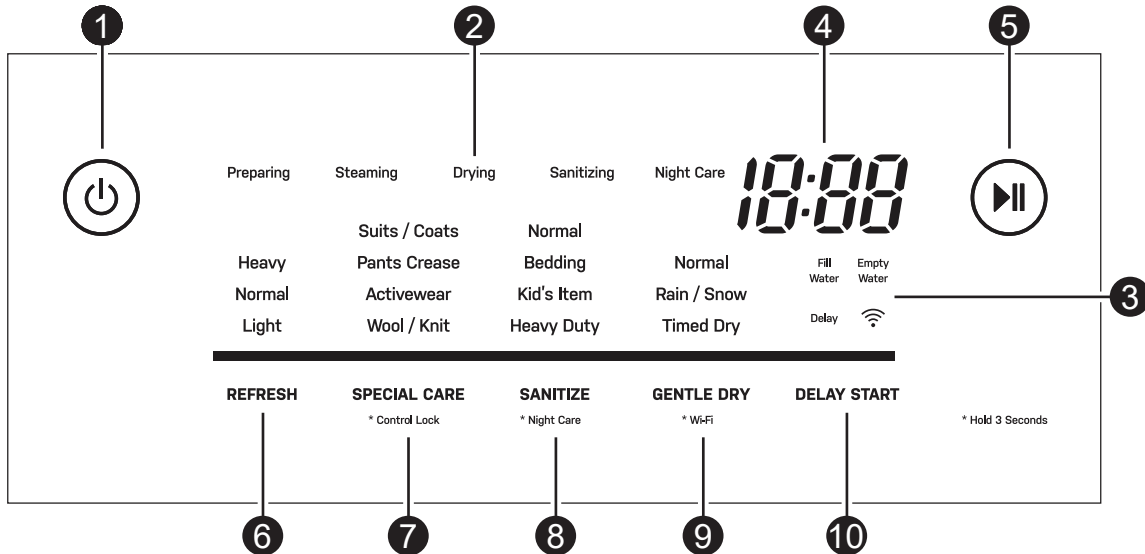

1 Power On/Off

Touch Power to turn the Fabric Care Closet ON/OFF. Once the cycle is complete, the Fabric Care Closet automatically turns off after a few seconds if no keys are touched.

NOTE: Touching Power during a cycle will cancel that cycle and the cycle settings will be lost.

2 Cycle Indicator

This portion of the display shows which stage of the styling cycle is currently underway (Preparing, Steaming, Drying, Sanitizing, or Night Care).

3 Option And Alert Indicators

Delay: Lights when the Delay Start feature is set.

Fill Water: Lights when the water supply tank is missing or empty.

Empty Water: Lights when the water drain tank is missing or full.

Night Care: Lights when the **Night Care** feature is set.

Wi-Fi: Lights when the Wi-Fi function is set.

4 Time Display

The display shows the estimated time remaining and error messages for the Fabric Care Closet. The cycle time may vary by usage conditions.

5 Start/Pause

Touch and hold to start the selected cycle. If the Fabric Care Closet is running, touch to pause the cycle without losing the current settings.

NOTE: If you do not touch Start/Pause to resume a cycle within an hour of pausing it, the Fabric Care Closet turns off automatically.

6 Refresh

Touch the icon to select a Refresh cycle. Touch repeatedly to toggle through the settings. See the **Cycle Guide** section.

7 Special Care / *Control Lock

Touch the icon to select a Special Care cycle. Touch repeatedly to toggle through the settings. Touch and hold the icon for three seconds to activate/deactivate the Control Lock function. See **Locking the Controls** section.

8 Sanitize / *Night Care

Touch the icon to select a SANITIZE cycle. Touch repeatedly to toggle through the settings. See the **Cycle Guide** section. Touch and hold the icon for three seconds to activate/deactivate the Night Care function. See **Night Care** section.

9 Gentle Dry / *Wi-Fi

Touch the icon to select a Gentle Dry cycle. Touch repeatedly to toggle through the settings. Press and hold for three seconds to activate the Wi-Fi function.

10 Delay Start

Set a delayed start time for the cycle. See **Setting a Delayed Start Time** section. Delay Start cannot be selected with the Night Care cycle.

Getting started

Cycle Guide

				Cycle Processes			
Cycle	Setting	Clothing / Fabric Type	Est. time in Hr.: Min.	Prepare	Steam	Sanitize	Dry
Refresh Cycle	Normal	suit, coat, school uniform, scarf, washable wool, knitwear, outdoor/performance clothing, towels, denim wear, t-shirts, socks, lingerie, sportswear, tablecloths	0:48	•	•		•
	Light		0:20	•	•		•
	Heavy		1:07	•	•		•
Special Care Cycle	Suits/Coats	Specially designed to quickly reduce odors from suits and coats.	0:35	•	•		•
	Pants Crease	Use with Pants Crease Care. Designed to accentuate the creases in pants.	1:07	•	•		•
Sanitize Cycle	Normal	Same as Refresh cycle, excluding wool and knitwear. Check Fabric Care Guide sections and fabric care labels in garments before use. Natural fibers must be marked washable/hand-washable and tumble dry, to avoid shrinkage. Do not use with items containing rubber, foam, or adhesive.	1:28	•	•	•	•
	Bedding		1:43	•	•	•	•
	Kid's Item		1:43	•	•	•	•
	Heavy Duty		2:13	•	•	•	•
Gentle Dry Cycle	Normal	Same as Refresh Cycle. Gentle Dry is also safe for many nonwashable garments such as silk ties, blouses, and other garments made from natural fibers such as 100% wool, cashmere, camel hair, and alpaca. See Choosing Fabric Care Closet - Safe Clothing section and always check garment labels before using.	2:00				•
	Rain/Snow		0:58	•	•		•
	Time Dry		0:30 - 2:30				•

Cycle Processes

- Preparing heats the water in the tank in preparation for supplying steam.
- Steaming sprays steam on the clothes.
- Sanitizing removes germs from the clothes.
- Drying removes moisture in the clothes.

Getting started

Choosing A Cycle

Fabric Care Closet cycles are designed to fit a variety of situations. Select the cycle and setting that best match the load contents and desired results for maximum performance and fabric care. For best results, pay attention to garment care labels and choose a cycle that is appropriate for the fabric content of the items. See the **Fabric Care Guide** section. For a guide to the symbols used on fabric care labels. Touch the cycle selector icon to select the desired cycle. Press the icon repeatedly to select the desired setting. When you select a cycle, the light for the default setting will turn on. See **Using the Fabric Care Closet** section for more details on operating methods.

Refresh Cycle

Use the Refresh cycle to reduce odors and wrinkles and to dry items. This cycle uses steam and should only be used with washable items. The cycle is safe for washable wool and knitwear.

Sanitize Cycle

Use the Sanitize cycle to reduce some germs and to dry items. The following organisms were tested for sanitization: staphylococcus aureus; pseudomonas aeruginosa; klebsiella pneumoniae. Choose this cycle for clothing, bedding, and children's clothing and soft toys. Quilts or blankets should be a single layer and weigh 3.3 lb (1.5 kg) or less. Do not use this cycle for wool or knitwear, because the high temperatures and steam can cause shrinkage.

Gentle Dry Cycle

Use the Gentle Dry cycle to reduce odors and wrinkles and to dry items. Use this cycle to sanitize and reduce at least 99% of bacteria and fungi in textiles and garments with innovative laundry technology that works to deeply refresh fibers. Choose this cycle for non-washable fabrics like cashmere.

Rain/Snow

Select this setting to refresh and gently dry damp clothing.

Getting started

Cycle Settings And Options

Starting a Cycle

	Suits / Coats	Normal	
Heavy	Pants Crease	Bedding	Normal
Normal	Activewear	Kid's Item	Rain / Snow
Light	Wool / Knit	Heavy Duty	Timed Dry
<hr/>			
REFRESH	SPECIAL CARE	SANITIZE	GENTLE DRY
	* Control Lock	* Night Care	* Wi-Fi

1. Touch **Power**.
2. Touch the cycle selector icon repeatedly until the desired cycle and setting is illuminated.
3. Touch **Start/Pause**.

Changing Settings During a Cycle

1. Touch Start/Pause to pause the cycle.
2. Touch the relevant cycle selector icon to change settings.

NOTES:

- During the Refresh and Sanitize cycles, the machine will make a boiling and hissing sound as water is boiled to make steam and steam is sprayed on clothes. This is normal.
- The moving hanger will move even when only the shelf is being used.
- Cycle times may vary depending on the usage environment, including water temperature.
- Cycle time for the Gentle Dry cycle varies depending on moisture level of items.
- Dryness uniformity may vary based on thickness of clothing.
- If the Sanitize cycle is changed to a Refresh or Gentle Dry cycle during operation, the sanitize process is not performed.

⚠ WARNING

- Do not open the door during operation. There is a risk of burns or injury from escaping hot air or steam.
- Do not allow steam or hot air to escape the cabinet during operation. Opening the door during operation also affects performance, lengthens drying time, and results in water condensing and collecting on the floor.
- Do not put very wet items in the Fabric Care Closet to dry. Shake off or wring out excess water before putting items in the cabinet to dry. If a large amount of water pools in the cabinet, drying performance may suffer or the product may be damaged.
- Remove or store the shelf when hanging longer items so items will not get wrinkled.
- Fasten buttons and zippers on hanging clothes to prevent them from falling off hangers during operation. Fasten the neck area with cotton string if there is no button or zipper.

Extra Functions

Some pads also activate special functions, including Control Lock, Night Care, Delay Start, and Wi-Fi.

Locking the Controls

Use Control Lock to prevent unwanted use of the Fabric Care Closet or to keep cycle settings from being changed while the Fabric Care Closet is operating.

1. Touch and hold the **Special Care** icon for three seconds to activate or deactivate the Control Lock function.
 2. "CL" appears in the display, and all controls are disabled except the **Power** pad.
- Control Lock does not lock the door.
 - The Control Lock setting is retained even if there is a power outage.
 - Once set, Control Lock remains active until it is manually deactivated. Control Lock must be deactivated to run another cycle.

Getting started

Setting a Delayed Start Time

Use the Delay Start function to delay the start time of the cycle.

1. Touch **Power**.
2. Touch the cycle selector icon for the desired cycle.
3. Touch **Delay Start** to set the start time of the cycle. The default delay time is three hours. Each time you touch the pad, the time increases by an hour, up to 19 hours.
 - Touch and hold the pad to increase the delay time more quickly.

⚠ WARNING

- Do not open the door during operation. There is a risk of burns or injury from escaping hot air or steam.
- Do not allow steam or hot air to escape the cabinet during operation. Opening the door during operation also affects performance, lengthens drying time, and results in water condensing and collecting on the floor.

Night Care

Use the Night Care function to store items overnight or anytime items cannot be removed soon after a cycle ends. Night Care periodically produces warm air to prevent condensation, keeping items warm and dry until they are removed.

- Once set, the Night Care function starts after the selected cycle ends.
- The Night Care function cannot be set to follow a Gentle Dry cycle.
- Night Care settings are lost if the **Power** pad is pressed.
- Night Care runs for a maximum of 24 hours.
- It is safe to open the door at any time during the Night Care function, even when the air is blowing.
- It is normal for the Night Care function to make noise periodically as it produces warm air.

SANITIZE

* Night Care

Press and hold **SANITIZE** for three seconds to select the night care function.

Setting the Night Care Function

1. Place clothes into the Fabric Care Closet.
2. Touch cycle selector icon repeatedly until desired cycle setting is selected.
3. Press and hold **SANITIZE** for three seconds to illuminate the LED and activate Night Care.
4. Touch Start/Pause.
5. To cancel Night Care, touch another cycle selector icon.

Getting started

Sorting Loads

Fabric Care Labels

Fabric care labels that can be used with the...			
Category	Label	Meaning	Fabric Care Closet
Washing Labels		Hand Wash	✓
		Machine Wash, Normal Cycle	✓
		Perm Press/Wrinkle Resistant	✓
		Gentle/Delicate	✓
		Do Not Wash	✓*
Drying Labels		Normal	✓
		Permanent Press/Wrinkle Resistant	✓
		Gentle/Delicate	✓
		Do Not Tumble Dry	✓
		Do Not Dry	NO
		Line/Hang Dry	✓
		Drip Dry	✓
		Dry Flat	✓
Dryer Heat Setting Labels		High	✓
		Medium	✓
		Low	✓
		No Heat/Air Dry	NO

Most articles of clothing feature fabric care labels that include instructions for proper care. Below are some of the symbols that are relevant to choosing appropriate items for the Fabric Care Closet.

*Some items such as fur and leather which are labeled as **do not wash** can be used with the Fabric Care Closet. See the **Fabric Care Guide** section.

Grouping Similar Items

- For best fabric care results, always treat fabrics with similar care requirements together.
- Different fabrics have different care requirements, and some fabrics cannot be treated in certain Fabric Care Closet cycles or should be treated separately.

Category	Non-Recommended Items
Clothes	starched clothes, vinyl
Bedding/Blankets	electric blankets, heavy blankets (double layer or over 3.3 lb [1.5 kg])
Other	shoes, items made with sponge rubber, items with adhesives

Choosing Recommended Clothing

Some items are not appropriate for use with this product.

- Follow fabric care labels.
- Do not put items that are sensitive to heat or are not suitable for washing with water in Fabric Care Closet cycles that use steam. Use the **Gentle Dry** cycle only.
- Fur, leather (only 100% natural leather), and silk items should only be treated with the Gentle Care cycle.
- Using the wrong cycle for items can result in damage to fabrics.
- Wash heavily soiled or stained clothes before putting them in the Fabric Care Closet. The Fabric Care Closet does not have a washing function. Loose soil or stains can be transferred between garments during cycles.
- Treat items with an unpleasant odor in a separate load. Odors can be transferred between items during cycles.
- Some odors can be difficult to remove. Odors from oily substances may be difficult for the steam to penetrate. Odors from extended storage may also be difficult to remove.
- Wrinkles may remain in some items. Wrinkles caused by extended storage may be difficult to reduce. Wrinkles in cotton or linen may not be reduced completely.

Getting started

Fabric Care Guide

■ = Yes
§ = Check Label

Fabric	Clothes	Refresh Cycle		Sanitize Cycle	Gentle Dry Cycle	Comments	
		Reducing Wrinkles	Removing Odors				
Natural Fibers	Cotton	towels, socks, underwear, jeans, sportswear, t-shirts, blankets		■	■	■	Wrinkles may remain in 100% cotton fabrics. Iron after cycle, if desired.
	Linen, Hemp, Ramie	summer clothes, tablecloths		■	■	■	Some wrinkles may remain. Make sure fabrics are washable/hand washable if using Refresh/Sanitize cycles. Lay clothes on shelf if delicate. Do not style starched clothes.
	Alpaca, Camel Hair, Cashmere	coats, suits	§	§	§	■	Lay knits on the shelf. Alpaca and camel hair shrink in hot water.
		scarves, knitwear		§		■	
	Fur, Leather	coats, scarves				■	Only use 100% leather (no artificial leather).
	Silk	silk neckties, ribbons, scarves, blouses, silk velvet/plush				■	Only use Gentle Dry cycle (low temperature drying).
Wool	sweaters, knitwear		§		■	Lay knits on shelf. Some wool shrinks when washed in hot water. Make sure fabrics are washable/hand washable if using Refresh/Sanitize cycles. Gentle Dry cycle is safe for most.	
	winter coats, suits, sportswear, uniforms	■	■	■	■		

Getting started

Fabric Care Guide (Cont.)

■ = Yes
§ = Check Label

Fabric	Clothes	Refresh Cycle		Sanitize Cycle	Gentle Dry Cycle	Comments	
		Reducing Wrinkles	Removing Odors				
Synthetic Fibers	Acetate	suit lining, blouses, neckties, pajamas	■	■	■	■	
	Acrylic	thermal underwear, knitwear	■	■	■	■	Lay clothes on shelf
	Nylon	stockings, lingerie	■	■	■	■	Lay clothes on shelf
		sportswear, curtains	■	■	■	■	
	Polyurethane	stretchable clothing (containing less than 5%)	■	■	■	■	If the item contains more than 5% polyurethane (swimwear), check label for care
	Rayon	suit lining	■	■	■	■	

- Fabrics come in a wide variety of weights and finishes and can have different care requirements for each variety. It is difficult to cover them adequately in this manual. Before using the Fabric Care Closet with any item, check the care label before proceeding. Do not put items that are not colorfast, are heat sensitive, or are not suitable for washing with water in the Refresh or Sanitize cycles. Do a water blot test on a small, inconspicuous spot (an inside seam) to determine if the fabric is colorfast. For further assistance, consult the clothing manufacturer, a dry cleaning professional, or a more detailed fabric care guide.
- Using the Fabric Care Closet with items that are very wet or are not colorfast may result in damage to the items and staining from fabric dyes on the interior of the cabinet. These stains will not affect the operation of the Fabric Care Closet. Use toothpaste to remove stains from interior of cabinet.
- The Fabric Care Closet does not have a washing function. Wash soiled items before use.

Getting started

Checking The Water Tanks

Check the water in the water tanks before use. The water supply tank must be filled with water before using the Fabric Care Closet. The Fabric Care Closet does not work without water. The water drain tank should be emptied before each use.

1. Pull the handle of each tank forward to remove the tank and check the level of water.

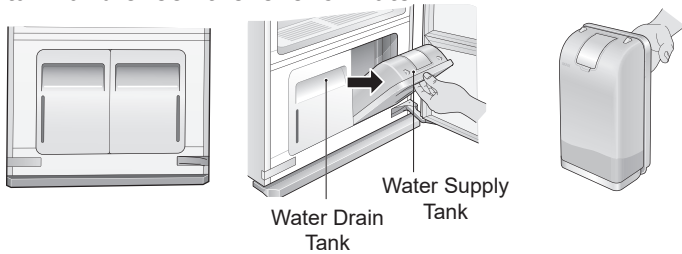

2. Make sure the water supply tank is filled with water.

The full water supply tank can be used for approximately four cycles, depending on the cycles used. Use clean tap water or bottled water for best performance and longer product life. Do not use distilled water or reuse the water from the drain tank.

The first time the Fabric Care Closet is used, 2/3 of the water in the fully filled water supply tank is used. Less water is used in following cycles.

NOTES:

- Only use water when filling the water supply tank. Any other substance, such as detergent or fabric softener, may damage the Fabric Care Closet.
- Use only clean tap water or bottled water. Foreign materials in the water may shorten the lifespan of the Fabric Care Closet.
- Do not use distilled water. The water sensor may not work.
- Do not reuse the water in the drain tank to fill the water supply tank.

3. Make sure the water drain tank is empty. The drain tank will be filled after about three cycles. The tank fills more quickly during drying cycles. The Fabric Care Closet does not work if the drain tank is full.

- Some discoloration of the water drain tank may occur over time. This is normal and will not affect product performance.

Loading The Fabric Care Closet

▲ WARNING

- Check all pockets to make sure that they are empty. Items such as clips, pens, coins, and keys can damage both the Fabric Care Closet and your clothes. Flammable objects such as lighters or matches could ignite, causing a fire. Failure to remove items can result in fire, explosion, or death.
- Never dry clothes that have been exposed to oil, gasoline, or other flammable substances. Washing clothes will not completely remove oil residues. Failure to obey this warning can result in fire, explosion, or death.
- Remove empty hangers from the moving hanger and place them on the shelf before starting the cycle. Empty hangers may cause unnecessary noise, friction, and damage to fabrics. See **Storing Hangers** section.
- Hang hangers in the same direction on the moving hanger to prevent collisions.

Accessory	Items to use it with
Hangers	shirts, dresses, suits, coats, skirts, pants without creases or too large for pants press, or any item that can use a hanger
Pants Crease Care	pants when creases are desired
Shelf	sweaters, wool, knitwear, lingerie, shoes, hats, toys, and other clothing or items that cannot use hangers

Getting started

The Moving Hanger

Hang clothes on the moving hanger using the hangers provided with the Fabric Care Closet, or use any plastic or metal hanger that hooks snugly into the indentations in the moving hanger.

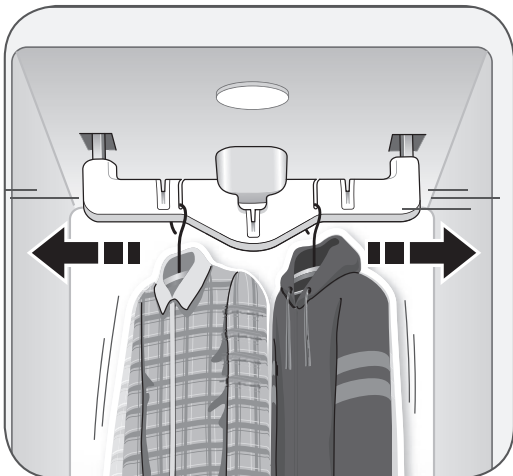

- Use the moving hanger for suits, coats, jackets, blouses, dresses, skirts, and pants that do not require a crease. Use the Pants Crease Care to crease pants.
- Anything that can be securely placed on a hanger and steamed or dried without retaining hanger marks or other damage can be placed on the moving hanger.
- Dry sweaters or knits on the shelf to avoid hanger marks.
- Clothing should be securely fastened, with zippers and buttons closed, so that it does not fall off the moving hanger during the cycle.
- Arrange clothing so it does not touch the sides or rear of the cabinet, if possible. Condensation may form on the interior surface of the cabinet, and items in contact with the surface may remain damp at the end of the cycle. Hang larger items on the diagonal indentations on the moving hanger.

▲ WARNING

Do not lean or pull on the moving hanger. Do not allow children play with or hang onto the moving hanger. The unit could tip, resulting in damage or injury.

The Pants Crease Care

Hang clothes in the Pants Crease Care using the pants hanger provided with the Fabric Care Closet or any pants hanger that fits into the hooks above the door to the Pants Crease Care.

- Open the door to the Pants Crease Care by pressing the icon on the front.

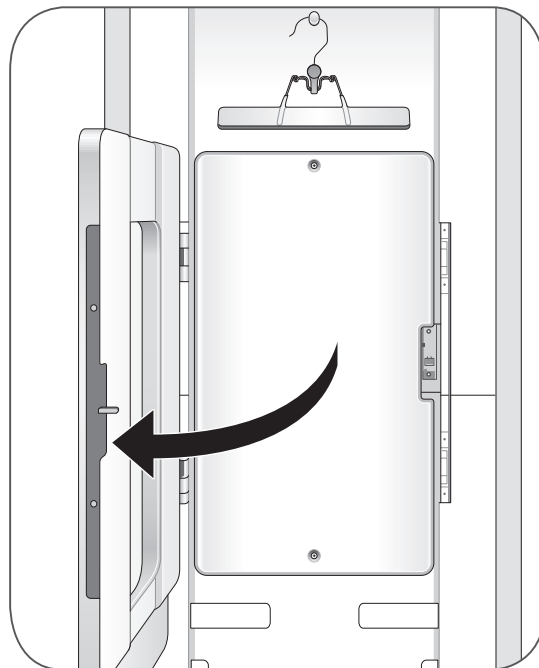

- The Pants Crease Care keeps pants legs creased.
- Pants can be pressed while refreshing other items in the same cycle.

NOTE: To avoid double creases, run a steam cycle using the moving hanger to reduce any existing knife pleats, and then use the pants press.

▲ WARNING

- Do not lean on or hang heavy items on the door of the Pants Crease Care. The unit may tip, resulting in damage or injury.
- Do not allow children to play with or hang onto the door of the Pants Crease Care. The unit may tip, resulting in damage or injury.
- Keep fingers out of pinch point areas when closing the door of the Pants Crease Care. Supervise nearby children to prevent injuries.

Getting started

Hangers

The hangers that come with the Fabric Care Closet are for use with the Fabric Care Closet only. Any plastic or metal hanger that has a hook less than 5/32 in. (4 mm) thick and hooks snugly into the indentations in the moving hanger can be used in the Fabric Care Closet.

- Do not use hangers with wool, knitwear, or delicate lingerie. The garments may stretch or be left with hanger marks.
- Wrinkles may appear at the back of the collar on some garments.
- Use the diagonal hanger grooves in the moving hanger for large or bulky items.
- Remove empty hangers or store them on the shelf during operation. See **Storing Hangers** section.

1. Select an appropriate hanger. Choose the Fabric Care Closet hanger that fits the item you are hanging up.
2. Fasten the buttons and zippers on all garments and hang them on hangers. Doing so helps keep the garments from falling or becoming more wrinkled during the cycle. If a garment has no buttons or zipper, fasten it with a cotton string around the collar area.
3. Place the hangers into the slots of the moving hanger

Using the Moving Hanger

1. Insert hangers into slots and pull down to secure the hook snugly.
Hooks should fit down in the slots snugly to prevent noise, vibration, or damage to items during operation.
2. Use the diagonal slots (2 and 4) for bulky items.
Do not use diagonal slots and standard slots during the same cycle. The hangers may knock into each other and damage clothing.

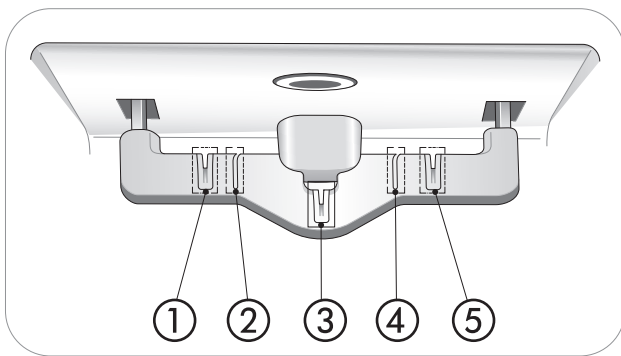

3. Do not overcrowd items.
The fewer items, the better the drying performance. Items that touch the sides of the cabinet may pick up condensation from the cabinet and fail to dry completely.

Pants Hanger or Pants Crease Care

Place pants either on the moving hanger or in the Pants Crease Care, depending on whether maintaining the creases on the pants legs is desired.

- Hanging pants on the moving hanger may reduce the creases on pants legs.
- To maintain the creases on pants legs, use the Pants Crease Care.
- The Pants Crease Care is not designed to work with pants that are wider than 38 in. (96 cm) or longer than 43 5/16 in. (110 cm). Check the size of the pants before using the Pants Crease Care. If pants are too large, use the moving hanger.

Opening and Closing the Pants Hanger

- To open, fold the hook down toward the hanger blades to unlock and separate the blades.

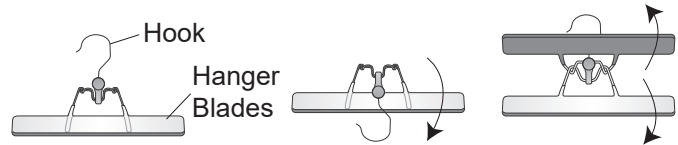

- Once pants are inserted, bring the blades together and rotate the hook up and away from the blades to lock them in place.

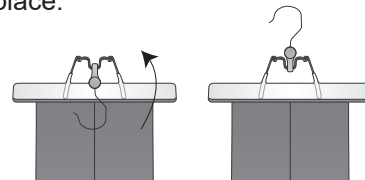

Hanging Pants On the Pants Hanger

1. Remove all objects from pants pockets and button the back pockets.
2. Fold pants along crease lines (or where crease lines would be), and attach the pants hanger at the ends of the pants legs.
3. Tug gently on the sides of the pants legs. Make sure pants are stretched tight within the hanger, with no wrinkles, and will not fall out of the hanger during the cycle.

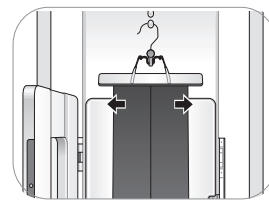
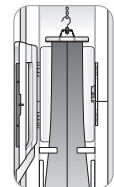

4. Place the pants hanger on the moving hanger or in the Pants Crease Care.



Getting started

Using the Pants Crease Care

1. Open the Pants Crease Care by pressing on the icon on the side.

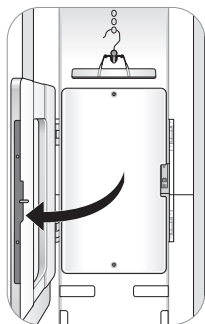

2. Hang the pants hanger on the hook above the Pants Crease Care that best fits the length of the pants being pressed.
If the pants are longer, use the higher hooks to keep the pants from hitting the floor of the cabinet.

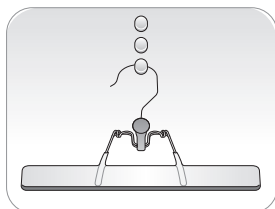

The Pants Crease Care is not designed to work with pants that are wider than 38 in. (96 cm) or longer than 43 5/16 in. (110 cm). Check the size of the pants before using the Pants Crease Care. If pants are too large, use the moving hanger.

3. Make sure the pants are hanging straight.
Check the creases on the legs to make sure they are lined up. Fix the pants with 2 clips before closing the Pants Crease Care. If the pants legs are not aligned properly or the pants are not hanging straight, double lines may appear at the pants' edges, or the pants may be wrinkled.

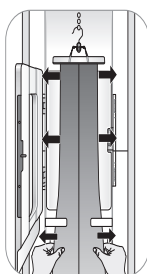

4. Close the Pants Crease Care, then straighten the pants once more.
Gently tug the edges of the pants to smooth out any wrinkles. Make sure the pants are hanging straight in the Pants Crease Care.

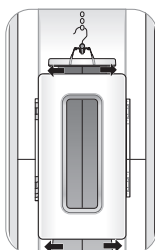

The Shelf

Use the shelf when styling clothes or other items that are difficult to hang or that may be damaged by hang drying.

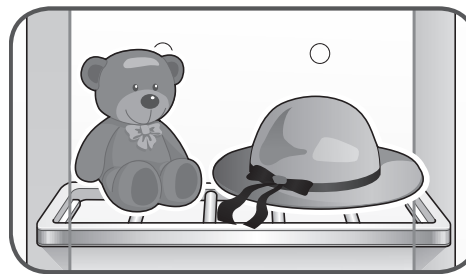

- Use the shelf for stuffed toys, pillows, hats, and other accessories.
- Use the shelf for sweaters, knits, lingerie, or delicate blouses that can show hanger marks, stretching, or other damage if dried on a hanger.
- For best drying performance, do not stack items on the shelf. Dry single items or place items side by side with space between.
- When not in use, store the shelf on the shelf holder knobs in the back of the cabinet.
- For instructions on installing the shelf, see **Assembling the Shelf** section. Do not use the shelf for storing heavy items.
- Arrange items on the shelf so they do not touch the sides or rear of the cabinet, if possible. Condensation may form on the interior surface of the cabinet, and items in contact with the surface may remain damp at the end of the cycle.

▲ WARNING

- Do not use the shelf to store heavy items. The shelf may fall, resulting in damage or injury.
- Do not step or sit on the shelf. The shelf may fall or the unit may tip, resulting in damage or injury.

Getting started

Choosing Fabric Care Closet Features

Item	Placement
Suit Coat, Blazer	Moving Hanger
Coat, Jacket (Short)	
Coat (Long)	Moving Hanger (Remove Shelf)
Dress (Short)	Moving Hanger
Dress (Long)	Moving Hanger (Remove Shelf)
Skirt	Moving Hanger
Lightweight Blanket, Throw	
Baby Blanket	
Pants (Not Creased)	
Shorts	
Children's Clothes	
Scarf	Moving Hanger Or Shelf
Tie	
Shawl	
Lingerie	Moving Hanger Or Shelf (if Delicate)
Shirt, Blouse	
Pants (Creased)	Pants Crease Care
Cap, Hat	Shelf
Stuffed Toys	
Pillow	
Sweater	
Knitwear	
Infant Clothes	

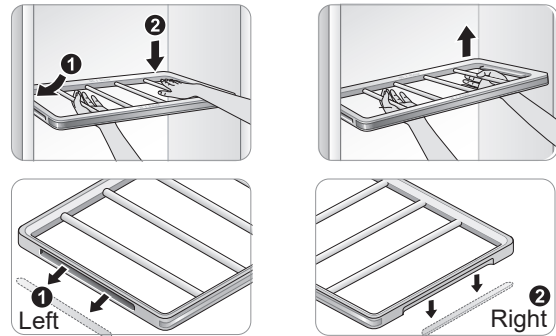

- To disassemble, lift up the right side of the shelf, then pull out the left side of the shelf from the shelf support.

⚠ WARNING

- The shelf cannot be assembled by sliding it into the cabinet. It will fall if not assembled properly.
 - Do not place heavy objects on the shelf or use it to store objects. Doing so can cause the product to malfunction.
 - Do not allow children to climb on or hang on the shelf. They could be injured.
- Hang the shelf on the shelf holder when treating long clothes such as coats or dresses.

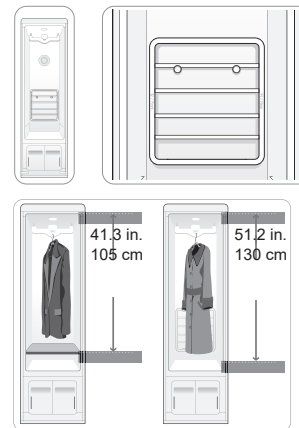

Shelf

Use the shelf for clothes and items that cannot be placed on hangers. Do not stack items on the shelf. For best drying performance, use the shelf for a single item or smaller items with space between.

Assembling the Shelf

- Hold the shelf so that the gray trim is toward the front.

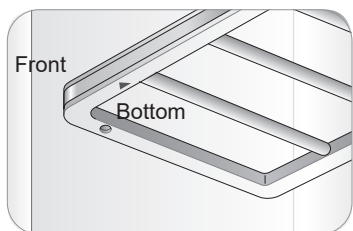

- Insert the left shelf groove into the left shelf support, then lower the right shelf groove onto the right shelf support.

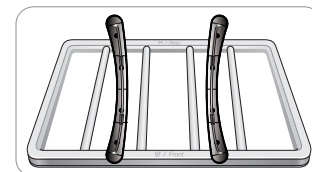

Storing Hangers

Remove unused hangers from the moving hanger and store them in the shelf during operation. This prevents noise and damage to clothing.

- Insert the hangers between the rails of the shelf.
- When styling long clothes, if the shelf is stored on the shelf holder, store the hangers outside the unit during operation.
- Do not use the shelf to store heavy items.

Care and cleaning

Checking The Filters Before Every Load

Checking the Lint Filter

Always make sure the lint filter is clean before starting a new load; a clogged lint filter will increase drying times.

1. Open the front grill and take out the lint filter.

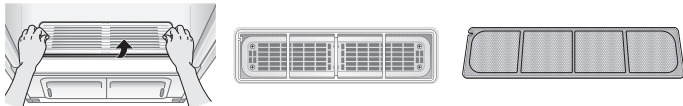

2. Brush the filter with a soft brush or clean it with a vacuum cleaner.
If the lint filter is torn or damaged, replace it with a new filter.

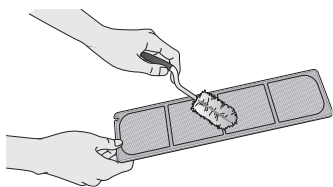

3. Reinstall the filter.

⚠ CAUTION Check that the sides are aligned correctly when inserting the grill.

Changing the Fabric Softener Sheet

Use a dryer fabric softener sheet to add a refreshing aroma to items. Replace the fabric softener sheet after every use.

1. Remove the aroma filter from the Fabric Care Closet.
2. Open the aroma filter and insert a dryer fabric softener sheet into it.



3. Close the aroma filter and insert it back in the Fabric Care Closet.
Insert the aroma filter in the direction of the arrow. You can adjust the opening of the perfume filter using the adjustment lever. The more open the aroma filter is, the richer the aroma gets.

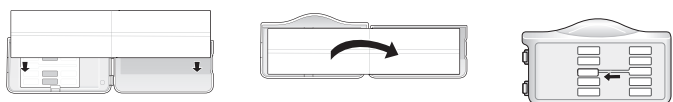

4. When the cycle is complete, remove the aroma filter and discard the fabric softener sheet.

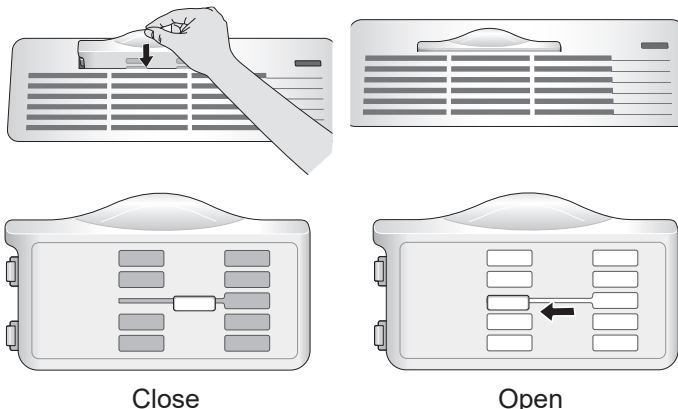

NOTE: To use your favorite perfume, spray it 4-5 times on a cotton pad and place the pad in the aroma filter. The strength of the resulting fragrance may vary depending on the scent used.

⚠ WARNING

To reduce the risk of fire, electric shock, or injury to persons when using this appliance, follow basic precautions, including the following:

- Unplug the Fabric Care Closet before cleaning to avoid the risk of electric shock. Failure to follow this warning can cause serious injury, fire, electrical shock, or death.

⚠ CAUTION

- Never use harsh chemicals, abrasive cleaners, or solvents to clean the Fabric Care Closet. They will damage the finish.

Cleaning the Interior and Exterior

Proper care of your Fabric Care Closet can extend its life.

1. Clean the inside and outside of the machine with a damp cloth. Glass cleaner can be used to clean the front glass panel, but spray it on a cloth and wipe rather than spraying it directly on the panel.
2. Buff the door dry with a clean, dry cloth to prevent any water stains.
3. Allow the interior and exterior to dry completely before plugging in and operating the product.

NOTES:

- Do not spray water directly on the product.
- Do not use detergent, methylated spirits, solvents, or any volatile liquids to clean the exterior of the product.
- Never use steel wool or abrasive cleansers; they can damage the surface.
- Keep sharp objects away from the exterior of the product. The touch panel may not work if damaged.

Care and cleaning

Cleaning the Lint Filter

Always remove the lint from the filter after every cycle. See **Checking the Lint Filter** section.

If the lint filter has become very dirty or clogged, wash the lint filter in warm, soapy water and allow to dry thoroughly before reinstalling.

- Never operate the Fabric Care Closet without the lint filter.
- Never operate the Fabric Care Closet with a wet lint filter.

Cleaning the Aroma Filter

For best results, wash the aroma filter using hot water and dish soap. After cleaning, wipe the filter with a clean cloth and allow it to dry thoroughly before reinstalling it.

The aroma filter can also be cleaned in the top rack of the dishwasher.

- Never operate the Fabric Care Closet without the aroma filter.
- Never operate the Fabric Care Closet with a wet aroma filter.

Cleaning the Water Tanks

The water in the water supply tank contacts the clothing and items treated in the Fabric Care Closet directly. Clean both tanks periodically and keep them clean at all times. If the tanks are not properly cleaned, they may start to smell or need to be replaced.

- Some discoloration of the water drain tank may occur over time. This is normal and will not affect product performance.
- Use only clean tap water in the supply tank for best performance and to prolong the life of the product. Do not use distilled water.
- Do not reuse the water from the water drain tank in the water supply tank.

1. Clean the exterior of the tanks with a wet cloth.
2. Use a cleaning brush or detergent made exclusively for water tanks to clean the inside of the water tanks. These can often be found online or at a local RV and camping store. Rinse tanks thoroughly after cleaning with detergent to remove any residue.

3. Make sure the drainage nozzle connected to the water drain tank and the water supply hole connected to the water supply tank are not clogged.

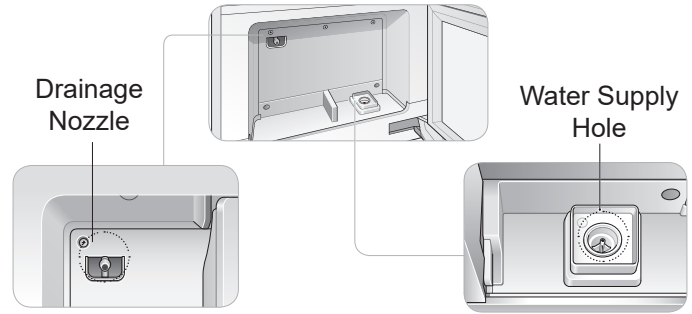

4. Allow the outsides of the tanks to dry completely before reinstalling the tanks.

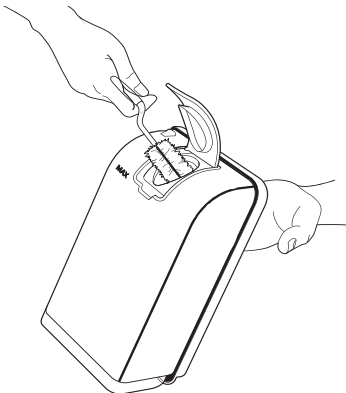
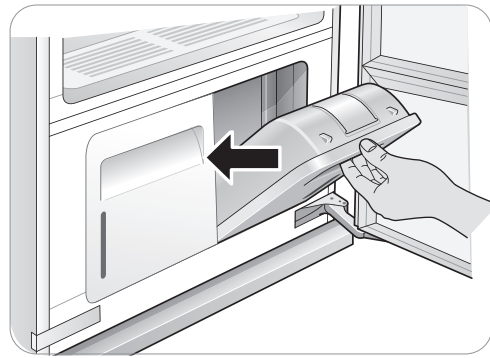

Installation Instructions

Fabric Care Closet

If you have any questions, call GE Appliances at 800.GE.CARES (800.432.2737) or visit our Website at: GEAppliances.com

BEFORE YOU BEGIN

Read these instructions completely and carefully.

- **IMPORTANT** — Save these instructions for local inspector's use.
- **IMPORTANT** — Observe all governing codes and ordinances.
- **Note to Installer** — Be sure to leave these instructions with the Consumer.
- **Note to Consumer** — Keep these instructions for future reference.
- **Skill level** — Installation of this appliance requires basic mechanical and electrical skills.
- **Completion time** — 1-3 hours
- Proper installation is the responsibility of the installer.
- Product failure due to improper installation is not covered under the Warranty.





LOCATION

DO NOT Install:

1. In an area exposed to dripping water or outside weather conditions. The ambient temperature should never be below 50°F (10°C) for proper operation.
2. In an area where it will come in contact with curtains or drapes.

NOTE: If floor is in poor condition, use 3/4" impregnated plywood sheet solidly attached to existing floor covering.

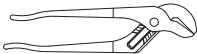
TOOLS REQUIRED

- Level 
- Adjustable wrench 
- Channel-lock adjustable pliers 
- Phillips screwdriver 

PARTS SUPPLIED

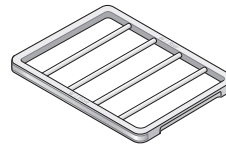

Shelf

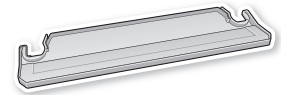

Drip Tray



2 Hangers

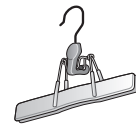

Pants Hanger

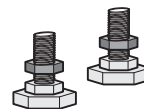

2 Rear Leveling Feet



2 Hinge Covers



Wrench



Anti-Tip Kit



2 Non-Skid Pads



2 Rear Cap Cover

GE Appliances Parts and Accessories

Order on-line at GEApplianceparts.com today, 24 hours a day or by phone at 877.959.8688 during normal business hours.

Part Number **Accessory**

PFA18REVV Door Reversing Kit

Installation Instructions

Installation Overview

Please read the following installation instructions first after purchasing this product or transporting it to another location.

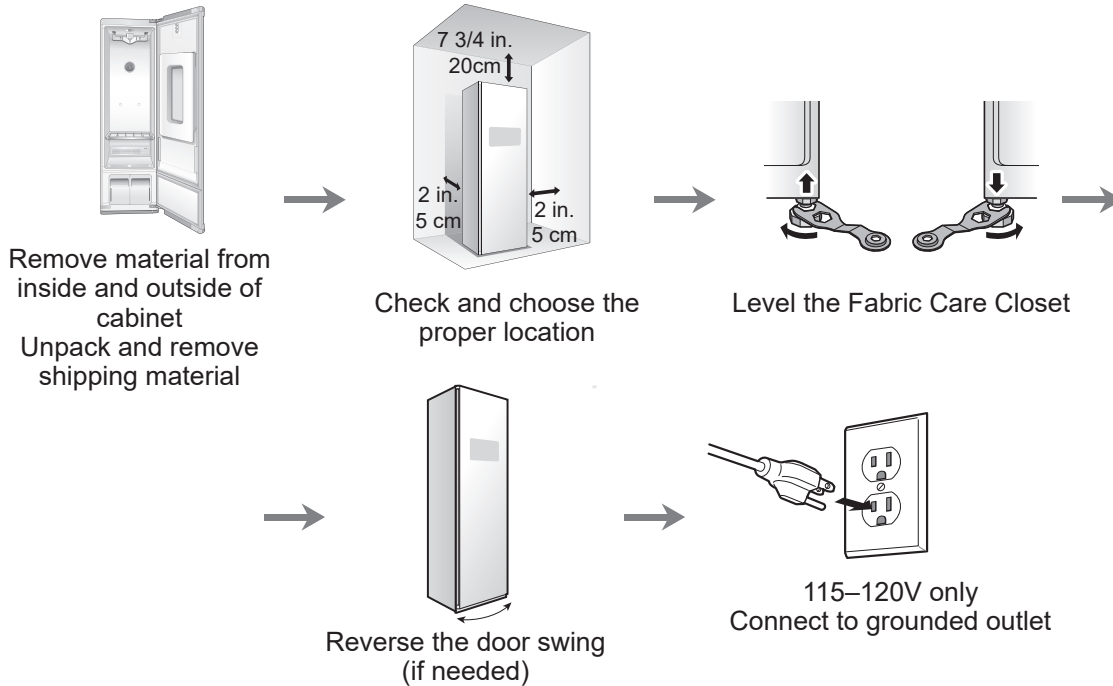

Product Specifications

The appearance and specifications listed in this manual may vary due to constant product improvements.

Description	electric machine for maintaining clothing
Electrical Requirements	120V, 12.5 Amps/Electric, 60Hz
Dimensions	17-1/2 in. (W) X 23 in. (D) X 72 13/16 in. (H), 39-3/4 in. (D with door open) 445 mm (W) X 585 mm (D) X 1850 mm (H), 1010 mm (D with door open)
Net Weight	172 lb (78 kg)
Maximum Capacity	4 items
Power Consumption	1500 W

Installation Instructions

Unpacking The Fabric Care Closet

⚠ WARNING

- Use two or more people to move and install the Fabric Care Closet. Failure to do so can result in back injury or other injury.
- The Fabric Care Closet is heavy. Use the wheels at the bottom of the product to move it. Push the Fabric Care Closet slowly from about halfway down the front side.
- Keep the Fabric Care Closet upright when moving it. If you lay the Fabric Care Closet on its side, refrigerant may leak and cause the appliance to malfunction.
- Keep flammable materials and vapors, such as gasoline, away from the Fabric Care Closet. Failure to do so can result in fire, explosion, or death.

- Remove tape and any temporary labels from the Fabric Care Closet before using. Do not remove any warning labels, the model and serial number label, or the Tech Sheet that is located under the front of the Fabric Care Closet.
- To remove any remaining tape or glue, rub the area briskly with your thumb. Tape or glue residue can also be easily removed by rubbing a small amount of liquid dish soap over the adhesive with your fingers. Wipe with warm water and dry.
- Do not use sharp instruments, rubbing alcohol, flammable fluids, or abrasive cleaners to remove tape or glue. These products can damage the surface of the Fabric Care Closet.

Choosing The Proper Location

Electricity	<p>Install where an outlet is easily accessible. Use a single, dedicated grounded outlet: 120 Volts, 60 Hz, AC, 15 Amps minimum.</p> <p>⚠ WARNING Do not plug in multiple appliances in the same outlet with the Fabric Care Closet. Overloading house wiring can cause a fire hazard. To reduce the risk of electric shock, do not install the Fabric Care Closet in a wet or damp area.</p>
Floor	<p>Floor must be level and solid enough to support 172 lb (78 kg). Adjust the leveling legs to compensate for any unevenness in the floor. Do not install on a platform or a weakly supported structure. If installing on carpeting, see Installing on Carpeting section.</p>
Ambient temperature	<p>Temperature must be between 50°F (10°C) and 95°F (35°C). If the ambient temperature is too low or high, performance may be affected. Do not install in direct sunlight or where the temperature may fall below 32°F (0°C).</p>
Clearances	<p>Allow at least 18 in. (46 cm) in front to open the door. Allow at least 2 in. (5 cm) on both sides and between the back of the Fabric Care Closet and the wall. Allow at least 7 3/4 in. (20 cm) between the top of the Fabric Care Closet and any overhanging shelves or cabinets. If the Fabric Care Closet is too close to adjacent items, performance may decrease and electricity consumption may increase.</p>

Installation Instructions

Installation Location Requirements

⚠ WARNING Read all installation instructions completely before installing and operating the Fabric Care Closet. It is important to review this entire manual before installing and using the Fabric Care Closet.

The installation requires:

- A grounded electrical outlet located within 2 ft. (61 cm) of either side of the appliance.

⚠ WARNING Do not install or store the Fabric Care Closet in an area where it will be exposed to water and/or weather. Failure to follow this warning could result in risk of electric shock, injury, or product damage or malfunction.

Clearances

⚠ WARNING

- The floor must be level, with a maximum slope of 1 inch (2.5 cm) under the Fabric Care Closet. If the slope is greater than 1 inch (2.5 cm), the appliance cannot be leveled properly.
- Do not install the Fabric Care Closet on a hollow or flexible platform. Doing so may cause excessive noise and vibration and result in damage or injury if the product tips over.

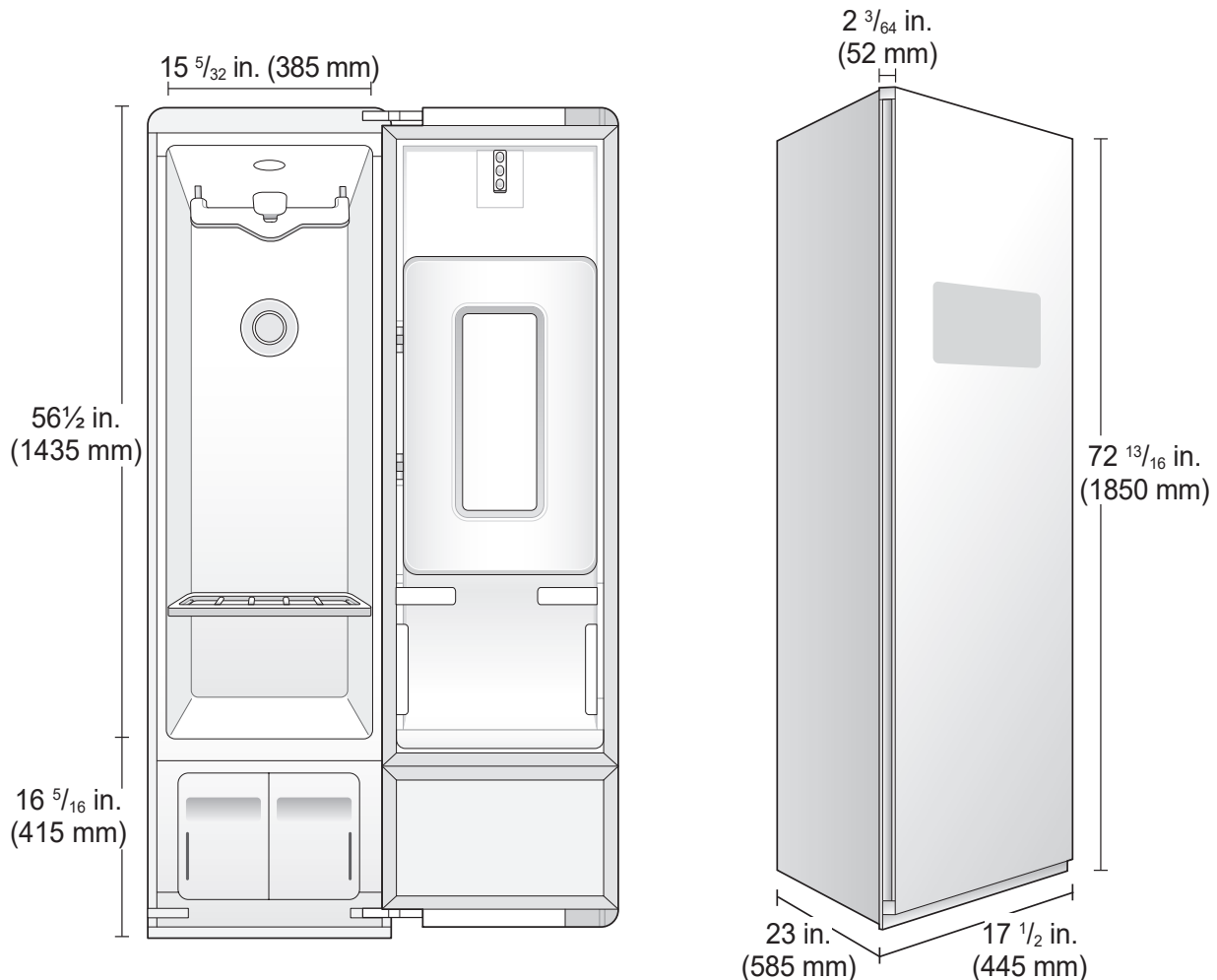

Installation Instructions

Recommended Installation Spacing

The following clearances are recommended for the Fabric Care Closet. Although the Fabric Care Closet has been tested for clearances of 1 3/16 inch (3 cm) on the sides and rear, recommended clearances should be considered for the following reasons:

- Additional space should be considered for ease of installation and servicing.
- Additional space might be required for wall, door and floor moldings.
- Additional space should be considered on all sides of the Fabric Care Closet to reduce noise transfer.
- Additional laundry appliance spacing should also be considered.

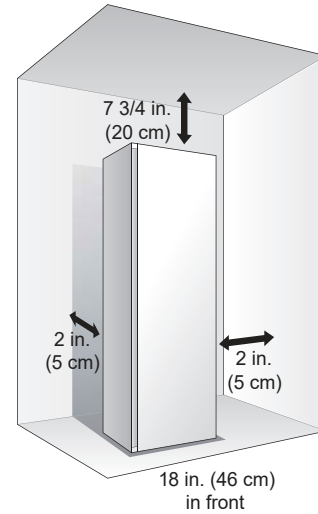

Installation Spacing for Recessed Area or Closet Installation

There should be at least a little space around the Fabric Care Closet (or any other appliance) to avoid contact with walls, furniture, or other appliances during operation. Allow a minimum of 1-3/16 inch (3 cm) on all sides of the Fabric Care Closet to avoid increased noise or damage.

- For closet installation, with a door, minimum ventilation openings in the top and bottom of the door are required. Louvered doors with equivalent ventilation openings are acceptable.

- Minimum vent opening for built-in installation is 31-1/2 sq. in. (200 cm²).

Built-In Installation

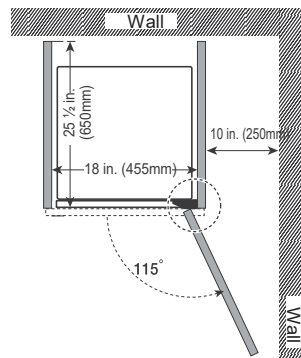

Closet Ventilation Requirements

Closets with doors must have both an upper and lower vent to prevent heat and moisture buildup in the closet. One upper vent opening with a minimum opening of 48 sq. in. (310 cm²) must be installed no lower than 6 feet above the floor. One lower vent opening with a minimum opening of 24 sq. in. (155 cm²) must be installed no more than one foot above the floor. One example shown uses vent grilles in the door.

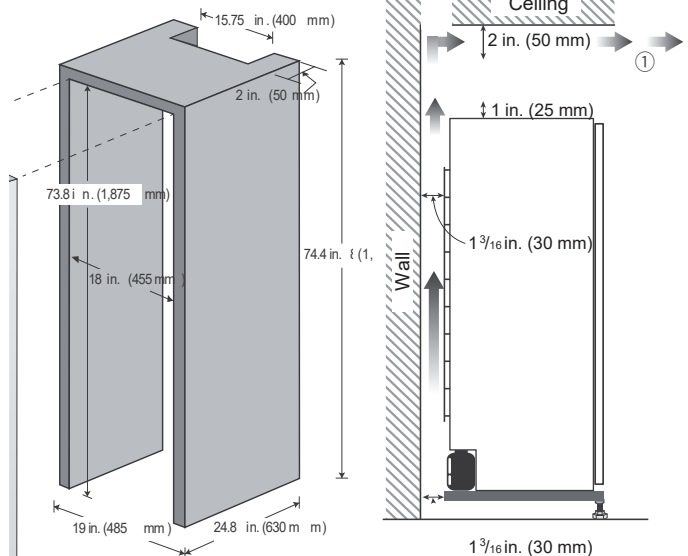
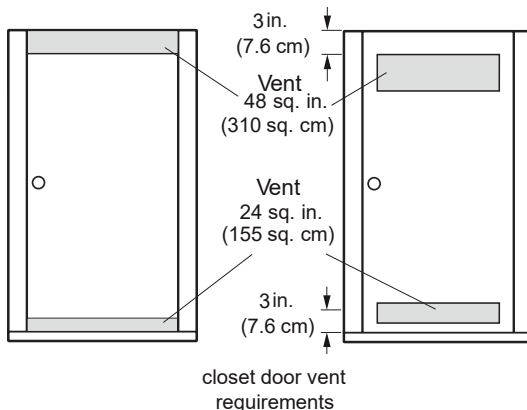

Installation Instructions

Leveling the Fabric Care Closet

The following clearances are recommended for the Fabric Care Closet. Although the Fabric Care Closet has been tested for clearances of 13/16 inch (3 cm) on the sides and rear, recommended clearances should be considered for the following reasons:

- Additional space should be considered for ease of installation and servicing.
- Additional space might be required for wall, door and floor moldings.
- Additional space should be considered on all sides of the Fabric Care Closet to reduce noise transfer.
- Additional laundry appliance spacing should also be considered.

▲ WARNING To reduce the risk of injury to persons, adhere to all industry recommended safety procedures including the use of long-sleeved gloves and safety glasses. Failure to follow this warning can cause serious injury or death. The appliance is heavy. Two or more people are required when installing the Fabric Care Closet. Failure to follow this warning can cause serious injury or death.

- To ensure that the Fabric Care Closet provides optimal performance, it must be level. To minimize vibration, noise, and unwanted movement, the floor must be a perfectly level, solid surface.



NOTE: Adjust the leveling feet only as far as necessary to level the Fabric Care Closet. Extending the leveling feet more than necessary can cause the Fabric Care Closet to vibrate.

1. Position the Fabric Care Closet in the final location. Check to make sure it is level. If installing on carpet, see the **Installing on Carpeting** section first.

- All leveling feet must rest solidly on the floor. Gently push on the corners of the Fabric Care Closet to make sure that it does not rock from corner to corner. Make sure there are no gaps between the front leveling feet and the floor.

▲ WARNING

- The Fabric Care Closet is heavy. Use two or more people if installing the rear leveling feet. Failure to do so can result in back injury or other injury.
- Keep the Fabric Care Closet upright when moving and installing it. If you lay the Fabric Care Closet on its side, refrigerant may leak and cause the appliance to malfunction.

2. Use the wrench (packaged with the manual) to turn the leveling feet. Unscrew the front feet to raise the Fabric Care Closet or screw in the feet to lower it. If unable to level the unit using only the front feet, install the two rear leveling feet by tipping the unit. Do not lay the unit down to install the leveling feet.

Raise or lower the unit using the leveling feet until the Fabric Care Closet is level from side to side and front to back.

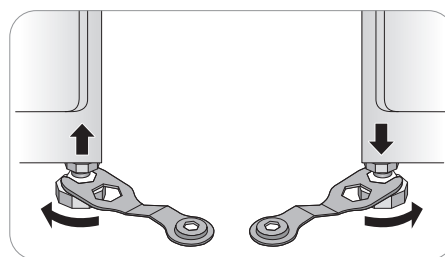

3. When the Fabric Care Closet is completely stable and all leveling feet are resting solidly on the floor, tighten the locking nuts.

▲ WARNING

Make sure that all leveling feet are in firm contact with the floor. If the Fabric Care Closet is used without leveling, it may fall, causing injury, damage, or product malfunction.

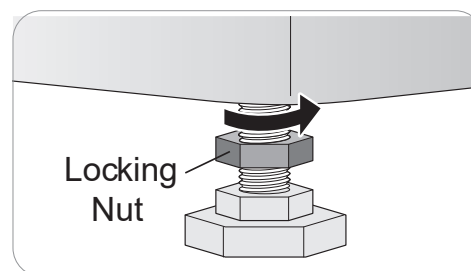

Installation Instructions

Reversing The Door

It is possible to reverse the direction of the door swing. This should be done by the installer at the time of installation, if desired. Instructions for reversing the door are included in door reversal kit.

⚠ WARNING Do not attempt to reverse the door swing yourself.

Installing On Carpeting

If installing the Fabric Care Closet on carpeting, follow these instructions.

1. Move the unit into its final location using the back rollers.

⚠ WARNING

- The Fabric Care Closet is heavy. Use two or more people to install the rear leveling feet and carpet spikes. Failure to do so can result in back injury or other injury.
- Keep the Fabric Care Closet upright when moving and installing it. If you lay the Fabric Care Closet on its side, refrigerant may leak and cause the appliance to malfunction.

2. Install the two rear leveling feet. Tip the unit, do not lay it down, to install the leveling feet.

3. Level the unit following the instructions in **Leveling the Fabric Care Closet** section.

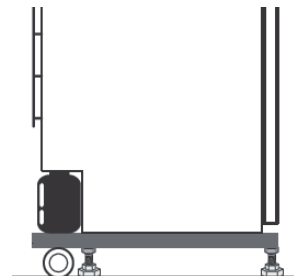

4. If the carpet has very deep pile or padding, the front feet may need to be extended slightly to install the drip tray.

- Be sure to check and empty the drip tray often.
- Do not open the unit during operation to avoid condensation forming on carpet surface, which may result in surface mold or mildew.
- Keep the bottom of the cabinet dry when filling or emptying water tanks. Keep the outside of the water tanks clean and dry to discourage growth of mold or mildew.

Installation Instructions

Installing The Anti-Tip Device

- Appliances can tip, resulting in damage or injuries. Do not operate the unit without the anti-tip device in place and engaged. If an anti-tip device is not properly installed, the appliance could be unexpectedly tipped by a child or adult standing, sitting, leaning, or placing excessive weight on an open door or the interior parts.
- Install the anti-tip device packed with the Fabric Care Closet to reduce the risk of tipping. Refer to the instructions provided with the anti-tip kit for proper anti-tip device installation.
- Check that the anti-tip device is properly installed. With the appliance in its final location, make sure that the slide adjuster on the cord is adjusted until there is about one inch of slack in the cord.
- The use of the anti-tip device does not preclude tipping of the appliance when it is not properly installed.

Assembling The Drip Tray

Before using the Fabric Care Closet, insert the drip tray onto the bottom of the cabinet.

1. Hold the tray so the arrow and letter on the front of the tray face up.
2. Insert one side of the tray first, then the other. Push the tray until it slides completely in.
3. To detach, pull one side out then the other. If the tray collects water, detach it and empty the water. After emptying it, re-assemble the tray.

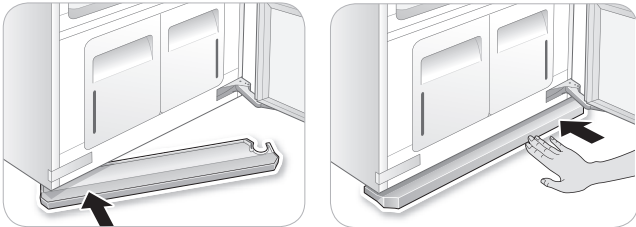

- Do not operate the Fabric Care Closet without installing the drip tray. Doing so could lead to water damage caused by leaking.

Installing Cap Covers

1. Line up the nubs on the cap cover with the holes in the top corner of the cabinet.
2. Snap the cap cover into place. Repeat with the remaining cap cover on the other corner.



Installing Hinge Covers

1. Open the Fabric Care Closet door.
2. Snap the hinge cover onto the lower hinge assembly with the bent edge on the far side from the hinge.

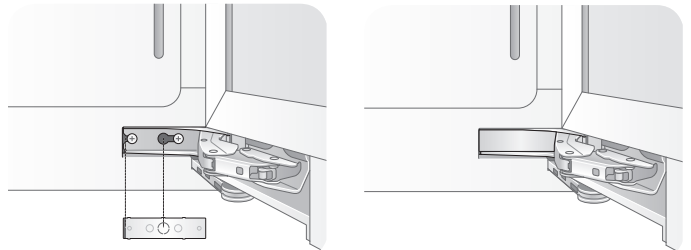

3. Repeat with the remaining hinge cover on the upper hinge assembly.

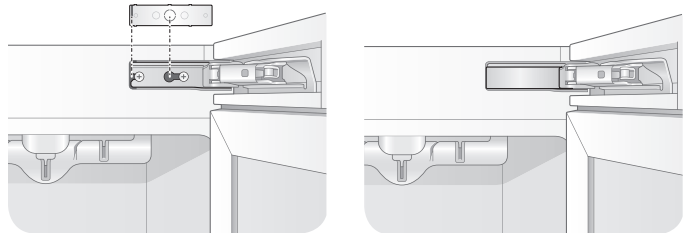

Troubleshooting Tips... Before you call for service

⚠ WARNING

Extra care must be taken to keep the area around the machine clean and dry. Do not open the cabinet during operation. There is a risk of burns or injury, and condensation from escaping hot air or steam could result in damage to carpeting.

FAQS: Frequently Asked Questions

Q:	What are aroma sheets and how do I use them?
A:	You can use your favorite brand of dryer fabric softener sheets in the aroma filter to infuse items with a refreshing aroma. The sheets will not soften garments or reduce static. To use the aroma filter, add a softener sheet before running a cycle. Dispose of the softener sheet at the end of the cycle. For best performance, clean the aroma filter after every 5-7 uses. See Changing the Aroma Sheet section and Cleaning the Aroma Filter section.
Q:	Why is the cycle time longer than estimated for the Gentle Dry cycle?
A:	The Fabric Care Closet uses a sensor to sense the dryness of fabrics. If clothing or other items are not dried properly, the cycle time is extended automatically (except for Time Dry cycles).
Q:	Can I install the Fabric Care Closet on carpeting?
A:	If installing on carpeting (especially on padded or deep pile carpets), stabilize the unit by installing the rear leveling legs. For instructions, see Installing on Carpeting section.

Troubleshooting Tips... Before you call for service

Before Calling For Service

Your appliance is equipped with an automatic error-monitoring system to detect and diagnose problems at an early stage. If your appliance does not function properly or does not function at all, check the following before you call for service.

Problem	Possible Cause	Solutions
Steam comes out when the door is opened	Door is opened during operation	It is normal for steam or hot air to escape if the door is opened during operation.
Full water supply tank is empty after just one use	Appliance is being used for the first time	A larger amount of water is needed the first time the appliance is used to fill the empty reservoir.
Appliance makes a loud vibrating noise on startup	Moving hanger is balancing load before operation	This is normal at the beginning of the cycle. If the noise increases or continues for a long time, call for service.
Drying times are taking longer than estimated	Clothes were extremely wet when loaded	Drying times may be longer for very wet or bulky clothing. Damp dry clothes before putting them in the Fabric Care Closet. The Fabric Care Closet stops automatically when clothes are dry.
Appliance is moving from left to right while operating	Floor under appliance is not level or is not sturdy enough to support the weight of the appliance without flexing	Install the appliance where the floor is level and sturdy. Compensate for any slight unevenness in the floor with the leveling legs. See Leveling the Fabric Care Closet section.
Sound of motor whirring	Compressor is running during drying	This is normal.
Sound of water running, boiling, or hissing	Steam being generated and sprayed onto clothes	This is normal.
Steam or hot air leaks out when the door is closed	An item is caught in the door, keeping it slightly open	Make sure all items are completely inside the cabinet and nothing is caught in the door, blocking it from closing completely.
The appliance will not operate	Control panel has powered off due to inactivity	This is normal. Press the Power pad to turn the appliance on.
	Cord is unplugged	Make sure cord is plugged securely into a working outlet.
	Circuit breaker/fuse is tripped/ blown	Check house circuit breakers/fuses. Replace fuses or reset breaker. The appliance should be on a dedicated branch circuit.
	Appliance not connected to 120 V socket	Make sure the cord is plugged into a grounded socket rated for this appliance. See the Product Specifications section.

Troubleshooting Tips... Before you call for service

Problem	Possible Cause	Solutions
Control panel will not respond	Control panel or pad has dirt on it	Dirt or foreign objects on the control panel will interfere with the operation of the pads. Clean the control panel.
	Control panel is locked	Disable the Control Lock function. See Locking the Controls section.
The cycle will not start	Start/Pause was not touched after the cycle was set.	Touch Start.
	Cycle is producing steam	There may be a period of inactivity while steam is produced.
	Control panel is locked	Disable the Control Lock function and touch Start. See Locking the Controls section.
Clothes are wet at the end of the cycle	Filter is clogged or grill is upside down	Clean the lint filter. Insert the grill with the holes on the right side.
	Door gasket is damaged	If the rubber door gasket is damaged, it leaves a gap in the door seal, affecting performance of the appliance. Call for service.
	Clothes caught in door	Make sure all items are completely in the cabinet and not stuck in the door, blocking it from closing completely. Run the cycle again.
Odor is not removed at end of cycle	Clothes were stored for a long period of time or are stained with a strong-smelling substance	Odors can be particularly difficult to remove from clothes that have been stored for long periods or have strong smelling, oily stains. Wash the clothes before using the Fabric Care Closet.
Wrinkles are not reduced at end of cycle	Clothes were stored for a long period of time	Wrinkles may be very difficult to reduce if set for a long time, especially in cotton and linen fabrics. Iron clothes that have been stored for a long period of time before treating them with the Fabric Care Closet, to reduce wrinkles more effectively.
Clothes have an unpleasant odor at end of cycle	Appliance has not been used for a long time or water tanks and filters have not been cleaned	Check for dirt or foreign objects in the water supply and water drain tanks. Clean the filters and water tanks.
Functions are not operating properly	Detergent or fabric softener put in water supply tank	Do not use anything but clean water in the water supply tank.

Troubleshooting Tips... Before you call for service

Problem	Possible Cause	Solutions
Wrinkles at back of neck after cycle	Item too large for hanger or fabric too delicate	Use the right size hanger for the item so the fabric won't bunch up and cause wrinkles. Some fabrics are delicate and will bunch around the hanger no matter what you do. Use the shelf for lingerie and other delicate items.
Creases are gone from pants after cycle	Pants were hung on the moving hanger, not in the pants press	Hang pants in the pants press to maintain creases at edge of pants legs.
Clothing has water spots after cycle, color has faded or run	Fabric is not washable, or is not colorfast	Check fabric care labels before treating items. See Sorting Loads section and the Cycle Guide section.
Fill Water icon is blinking	Water supply tank is empty or tank is missing	Fill the water supply tank and reinstall it.
Empty Water icon is blinking	Water drain tank is full or tank is missing	Empty the water drain tank and reinstall it.
dE Error is blinking	Door is not completely closed	Check that items are completely inside the cabinet and that the door is tightly closed.
AE, LE, LE2, E1, E4, TE1, TE2, TE3, TE5 shows on the display.	System error	Unplug the appliance and call for service.

GE Appliances Limited Warranty

LIMITED WARRANTY

GEAppliances.com

All warranty service is provided by our Factory Service Centers, or an authorized Customer Care® technician. To schedule service online, visit us at **GEAppliances.com/service**, or call GE Appliances at 800.GE.CARES (800.432.2737). Please have your serial number and your model number available when calling for service.

Servicing your appliance may require the use of the onboard data port for diagnostics. This gives a GE Appliances factory service technician the ability to quickly diagnose any issues with your appliance and helps GE Appliances improve its products by providing GE Appliances with information on your appliance. If you do not want your appliance data to be sent to GE Appliances, please advise your technician not to submit the data to GE Appliances at the time of service.

For the period of:	We will replace:
One year From the date of the original purchase	The inverter/compressor if it should fail due to a defect in materials or workmanship. During this limited one-year warranty , we will also provide, free of charge , all labor and related service to replace the defective part.

What is not covered:

- Service trips to your home to teach you how to use the product.
- Improper installation, delivery or maintenance.
- Failure of the product if it is abused, misused, or used for other than the intended purpose or used commercially.
- Replacement of house fuses or resetting of circuit breakers.
- Products which are not defective or broken, or which are working as described in the Owner's Manual.
- Damage to the product caused by accident, fire, floods or acts of God.
- Incidental or consequential damage caused by possible defects with this appliance.
- Defects or damage due to operation in freezing temperatures.
- Damage caused after delivery.
- Product not accessible to provide required service.

EXCLUSION OF IMPLIED WARRANTIES

Your sole and exclusive remedy is product repair as provided in this Limited Warranty. Any implied warranties, including the implied warranties of merchantability or fitness for a particular purpose, are limited to one year or the shortest period allowed by law.

This limited warranty is extended to the original purchaser and any succeeding owner for products purchased for home use within the USA. If the product is located in an area where service by a GE Appliances Authorized Servicer is not available, you may be responsible for a trip charge or you may be required to bring the product to an Authorized GE Appliances Service location for service. In Alaska, the limited warranty excludes the cost of shipping or service calls to your home.

Some states do not allow the exclusion or limitation of incidental or consequential damages. This limited warranty gives you specific legal rights, and you may also have other rights which vary from state to state. To know what your legal rights are, consult your local or state consumer affairs office or your state's Attorney General.

Warrantor: GE Appliances, a Haier Company, Louisville, KY 40225

Extended Warranties: Purchase a GE Appliances extended warranty and learn about special discounts that are available while your warranty is still in effect. You can purchase it online anytime at

GEAppliances.com/extended-warranty

or call 800.626.2224 during normal business hours. GE Appliances Service will still be there after your warranty expires.

Staple your receipt here. Proof of the original purchase date is needed to obtain service under the warranty.

Consumer Support

GE Appliances Website

Have a question or need assistance with your appliance? Try the GE Appliances Website 24 hours a day, any day of the year! You can also shop for more great GE Appliances products and take advantage of all our on-line support services designed for your convenience. GEAppliances.com.

Register Your Appliance

Register your new appliance on-line at your convenience! Timely product registration will allow for enhanced communication and prompt service under the terms of your warranty, should the need arise. You may also mail in the pre-printed registration card included in the packing material. GEAppliances.com/register.

Schedule Service

Expert GE Appliances repair service is only one step away from your door. Get on-line and schedule your service at your convenience any day of the year. GEAppliances.com/service or call 800.432.2737 during normal business hours.

Extended Warranties

Purchase a GE Appliances extended warranty and learn about special discounts that are available while your warranty is still in effect. You can purchase it on-line anytime. GE Appliances Services will still be there after your warranty expires. GEAppliances.com/extended-warranty or call 800.626.2224 during normal business hours.

Remote Connectivity

For assistance with wireless network connectivity (for models with remote enable), visit our website at GEAppliances.com/connect or call 800.220.6899.

Parts and Accessories

Individuals qualified to service their own appliances can have parts or accessories sent directly to their homes (VISA, MasterCard and Discover cards are accepted). Order on-line today 24 hours every day.

GEApplianceparts.com or by phone at 877.959.8688 during normal business hours.

Instructions contained in this manual cover procedures to be performed by any user. Other servicing generally should be referred to qualified service personnel. Caution must be exercised, since improper servicing may cause unsafe operation.

Contact Us

If you are not satisfied with the service you receive from GE Appliances, contact us on our Website with all the details including your phone number, or write to:

General Manager, Customer Relations | GE Appliances, Appliance Park | Louisville, KY 40225
GEAppliances.com/contact or call 800.626.2000