

FRIGIDAIRE

affinity.



Top Load Washer

FAHE1011MW

8 Wash Cycles
3.4 Cu. Ft. D.O.E.



Product Dimensions

Height	43"
Width	27"
Depth	29"

More Easy To Use Features

ENERGY STAR®

Vibration Control System

Advanced vibration control keeps even oversized loads balanced for smooth, quiet operation. Ideal for second floor installation.

DuraMotion™ Tub with Lifetime Warranty

Seamless tub helps create unique water action that gently, yet thoroughly, immerses clothes for better cleaning — and it has a lifetime warranty.

8 Cycles to Choose From

Offers you 8 wash cycles to choose from to meet your washing needs from washing bedding to delicate wash.

Fits-More™ Washer

Our new design lets you wash more in one load.

SilentDesign™

Designed for 20% quieter operation.

Automatic Temperature Control

Express-Select® Controls

Easily select options with the touch of a button.



ENERGY STAR®

Available in:



Classic White (W)

¹Among leading HE Top Load washer brands \$649 MSRP and under. Based on ANSI/AHAM HLW-1-2007 for 8 lb. load for various load compositions. Light Soil Wash Cycle setting selected August 2012.

Signature Features



Best Cleaning Wash

Our exclusive wash system cleans your clothes thoroughly, ensuring whiter whites and tough stain removal, for maximum cleaning even with large loads.



Gentlest Wash¹

Immersion Care™ Wash Action gently spins and moves water and detergent through clothes for more thorough, gentle cleaning.



Immersion Care™ Wash Action

Gently spins and moves water and detergent through clothes for more thorough, gentle cleaning.



Fresh Water Rinse

Final rinse uses fresh water to ensure whiter whites and reduce allergens.

Features	
Washer Type	HE Top Load
Total Capacity D.O.E. (Cu. Ft.)	3.4
Controls	Express-Select®
Washer Drum Interior	Polypropylene
Interior Light	
Vibration Control System	Yes
Framed Glass Window Lid	
Suspension System	Sure-Spin™
Wash System	Immersion Care™ Action
TimeWise® Technology	Yes
Fresh Water Rinse	Yes
WaterFall™ Wash	
Estimated Time Remaining	
Bleach Dispenser	Yes
Fabric Softener Dispenser	
Cycle Status Lights	Yes
Cycle Signal	
Cycle Signal "On/Off"	
Control Lock	
Start/Pause/Cancel Knobs	Yes
Delay Start	
Agitate Speed (Stroke/Min.)	Variable
Spin Speed (Maximum RPM)	600
Sound Package	SilentDesign™
Adjustable Leveling Legs	4
Cycles	
Wash Cycles	8
Specialty Cycles	0
Options	
Water Temperature Selections	4
Water Levels	Automatic
Spin Speed Selections	0
Soil Level Selections	0
Energy Saver Option	
Optional Accessories	
Mobile Home Installation Kit	PN# 137067200
Drain Hose Extension Kit	PN# 137098000
Certifications	
ENERGY STAR®	Yes
Specifications	
Power Supply Connection Location	Left Top Rear
Water Inlet Connection Location	Left Rear
Voltage Rating	120V / 60Hz / 15A
Connected Load (kW Rating) @ 120 Volts¹	0.295
Watts @ 120 Volts / Amps @ 120 Volts	295 / 4.0
Minimum Circuit Required (Amps)	15
Shipping Weight (Approx.)	171 Lbs.

¹For use on adequately wired 120V, dedicated circuit having 2-wire service with a separate ground wire. Appliance must be grounded for safe operation.

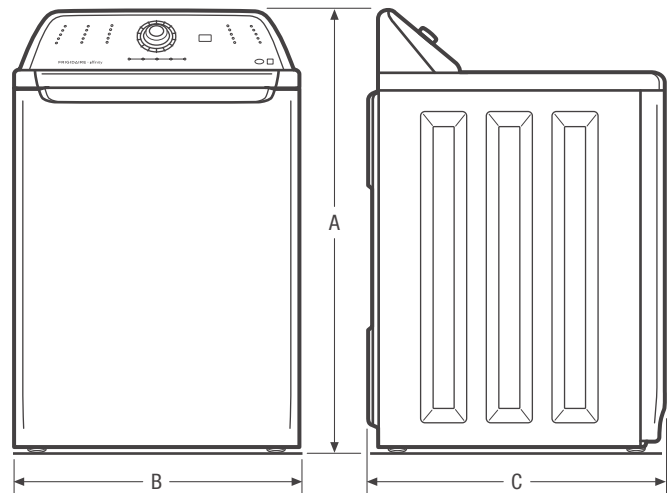

NOTE: For planning purposes only. Always consult local and national electric and plumbing codes. Refer to Product Installation Guide on the web at frigidaire.com for detailed installation instructions.



Product Dimensions	
A - Height	43"
B - Width	27"
C - Depth	29"

Accessories information available on the web at frigidaire.com

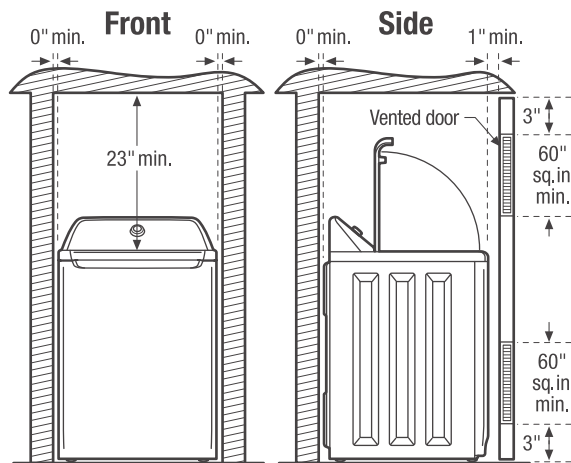
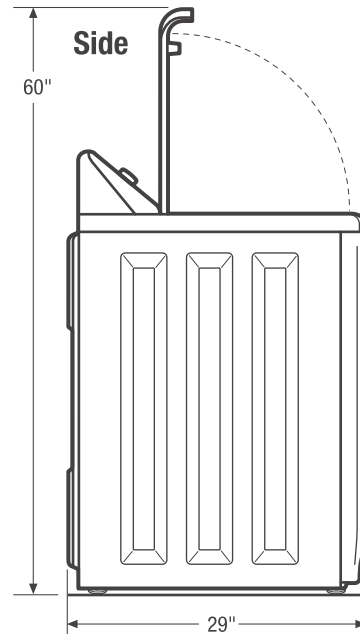
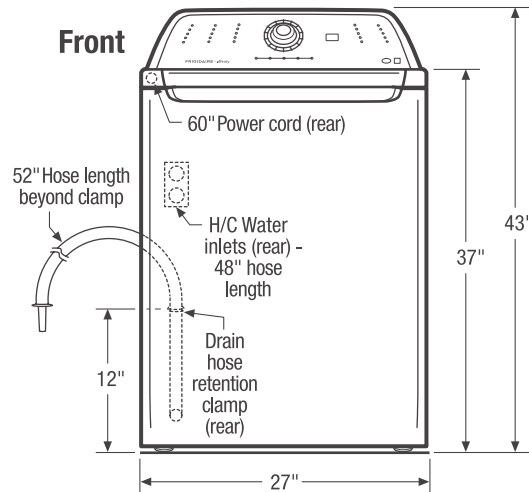

Recess or Closet Installation

Washer requires 0" minimum installation clearance around sides and back of unit. To achieve 0" minimum rear clearance when installed with dryer, dryer **MUST** be vented straight back. Closet installation requires additional 1" minimum clearance between front of unit and door. If washer and dryer are installed in same closet, door **MUST** be vented with 120 sq.in. minimum louvered opening, equally divided, located 3" from top and bottom of door. A louvered door with equivalent air openings for full-length of door is acceptable. Air openings **MUST** remain unobstructed with door installed. For additional installation details, refer to Product Installation Guide(s) on web.

Top Load Washer Specifications

- Product Shipping Weight (approx.) - 171 Lbs.
- An electrical supply with grounded three-prong receptacle is required. The power supply circuit must be installed in accordance with current edition of National Electrical Code (ANSI/NFPA 70) and local codes & ordinances. (*Do not use same circuit as dryer.*)
- Voltage Rating - 120V/60 Hz/15 Amps
- Amps @ 120 Volts = 4.0 Amps
- Equipped with 120V 3-wire power supply cord, approx. 60" long.
- Always consult local and national electric & plumbing codes.
- To maximize detergent effectiveness, ambient temperature should never be below 60° F.
- Washer can be installed in recess or closet requiring 0" minimum installation clearance around sides and back of unit. To achieve 0" minimum rear clearance when installed with dryer, dryer **MUST** be vented straight back. Closet installation requires additional 1" minimum clearance between front of unit and door. If washer and dryer are installed in same closet, door **MUST** be vented with 120 sq.in. minimum louvered opening, equally divided, located 3" from top and bottom of door. A louvered door with equivalent air openings for full-length of door is acceptable. Air openings **MUST** remain unobstructed with door installed. (*For additional installation details, refer to Product Installation Guide on web.*)
- Do NOT install in area exposed to dripping water or outdoor weather conditions; or where gasoline or other flammables, including automobiles, are kept or stored.
- Floor **MUST** be solid with 1" maximum slope. To minimize vibration or movement, reinforcement of floor may be necessary. Do NOT install on carpeted surface.
- Leveling legs supplied to level unit properly and reduce excessive noise and vibration.
- H/C water faucets **MUST** be installed within 42" of washer's water inlet and **MUST** be 3/4" with threading for laundry hose connection to connect to 48" inlet hoses.
- Water pressure **MUST** be between 30 and 120 psi with NOT more than 10 psi pressure difference between hot and cold.
- Drain standpipe requires diameter of 1-1/4" min. and height of 33" min./96" max. above floor, capable of eliminating 17 gallons per minute. Attached 52" drain hose can reach 74"-high standpipe. For higher standpipe, optional Drain Hose Extension Kit available.
- For manufactured or mobile home installation optional Mobile Home Installation Kit (PN# 137067200) required. (*For specific installation details, refer to Product Installation Guide on web.*)

Note: For planning purposes only. Refer to Product Installation Guide on the web at frigidaire.com for detailed instructions.

Optional Accessories

- Mobile Home Installation Kit - (PN# 137067200).
- Drain Hose Extension Kit - (PN# 137098000).