

# Refrigerator

## use & care

Introduction.....	2	Automatic Ice and Water Dispenser.....	20
Important Safety Information .....	3	Storage Features.....	23
Features.....	6	Storing Food and Saving Energy.....	27
Installation .....	7	Normal Operating Sounds.....	28
Door Removal.....	9	Filter Replacement .....	29
Door Handle Installation.....	13	Care and Cleaning .....	32
Water Supply Connection.....	14	Troubleshooting.....	34
Controls and Settings.....	16	Limited Warranty .....	39

## Welcome to our **family**

Thank you for bringing Frigidaire into your home! We see your purchase as the beginning of a long relationship together.

This manual is your resource for the use and care of your product. Please read it before using your appliance. Keep it handy for quick reference. If something doesn't seem right, the troubleshooting section will help you with common issues.

FAQs, helpful tips and videos, cleaning products, and kitchen and home accessories are available at Frigidaire.com.

We are here for you! Visit our website, chat with an agent, or call us if you need help. We may be able to help you avoid a service visit. If you do need service, we can get that started for you.

Let's make it official! Be sure to register your product.

Keep your product info here so it's easy to find.

Model Number \_\_\_\_\_

Serial Number \_\_\_\_\_

Purchase Date \_\_\_\_\_

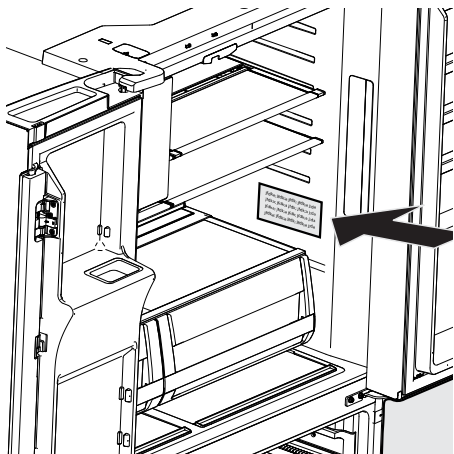

**Serial Number Location**



### **Installation Checklist**

#### **Doors**

- Handles are secure and tight
- Door seals completely to cabinet on all sides

#### **Leveling**

- Refrigerator is level side-to-side and slightly elevated in front to assist with door and drawer closing (front should be higher than back)
- Cabinet is setting solid on all corners

#### **Electrical Power**

- House power turned on
- Refrigerator plugged in

#### **Ice Maker**

- House water supply connected to refrigerator (Warning: Potable water supply only.)
- No water leaks present at all connections - recheck in 24 hours
- Ice maker is turned ON
- Ice & water dispenser operates correctly

#### **Final Checks**

- Shipping material removed
- Fresh food and freezer temperatures set
- Registration submitted



## WARNING

Please read all instructions before using this refrigerator.

### Safety Definitions

 This is the safety alert symbol. It is used to alert of potential personal injury hazards. Obey all safety messages that follow this symbol to avoid possible injury or death.



## DANGER

DANGER indicates an imminently hazardous situation which, if not avoided, will result in death or serious injury.



## WARNING

WARNING indicates a potentially hazardous situation which, if not avoided, could result in death or serious injury.



## CAUTION

CAUTION indicates a potentially hazardous situation which, if not avoided, may result in minor or moderate injury.



## IMPORTANT

IMPORTANT indicates installation, operation or maintenance information which is important but not hazard-related.



## DANGER



DANGER Risk of fire or explosion. Flammable refrigerant used. Do not use mechanical devices to defrost refrigerator. Do not puncture refrigerant tubing.

DANGER Risk of fire or explosion. Flammable refrigerant used. To be repaired only by trained service personnel. Use only manufacturer-authorized service parts. Any repair equipment used must be designed for flammable refrigerants. Follow all manufacturer repair instructions. Do not puncture refrigerant tubing.



## CAUTION



CAUTION Risk of fire or explosion. Dispose of refrigerator properly in accordance with the applicable federal or local regulations. Flammable refrigerant used.

CAUTION Risk of fire or explosion due to puncture of refrigerant tubing. Follow handling instructions carefully. Flammable refrigerant used.



## WARNING

**CALIFORNIA RESIDENTS ONLY**  
**Cancer and Reproductive Harm**  
**[www.P65Warnings.ca.gov](http://www.P65Warnings.ca.gov)**

# 4

## IMPORTANT SAFETY INFORMATION

### Safety Instructions

- DO NOT store or use gasoline, or other flammable liquids in the vicinity of this or any other appliance. Read product labels for warnings regarding flammability and other hazards.
- DO NOT operate the refrigerator in the presence of explosive fumes.
- Avoid contact with any moving parts of automatic ice maker.
- Remove all staples from the carton. Staples can cause severe cuts, and also destroy finishes if they come in contact with other appliances or furniture.



### WARNING

Do not use electrical appliances inside the food storage compartments of the appliance unless they are of the type recommended by the manufacturer.

### Child Safety

Destroy or recycle the carton, plastic bags, and any exterior wrapping material immediately after the refrigerator is unpacked. Children should **NEVER** use these items to play. Cartons covered with rugs, bedspreads, plastic sheets or stretch wrap may become airtight chambers, and can quickly cause suffocation.

### Proper Disposal of Refrigerator or Freezer

#### Risk of child entrapment

Child entrapment and suffocation are not problems of the past. Junked or abandoned refrigerators or freezers are still dangerous – even if they will sit for “just a few days”. When disposing of an old refrigerator or freezer, please follow the instructions below to help prevent accidents.

#### Proper Disposal of Refrigerators/Freezers

We strongly encourage responsible appliance recycling/disposal methods. Check with the utility company or visit [energy-star.gov/recycle](http://energy-star.gov/recycle) for more information on recycling an old refrigerator.

### Before disposing of an old refrigerator/freezer:

- Remove doors.
- Leave shelves in place so children may not easily climb inside.
- Have refrigerant removed by a qualified service technician.

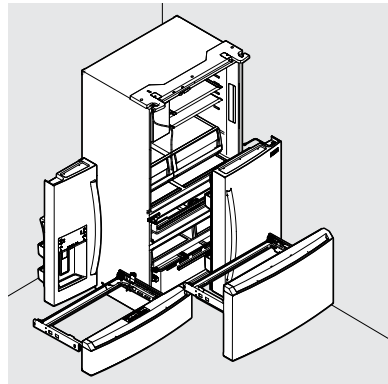

### IMPORTANT

#### CFC/HCFC Disposal

Some old refrigerators may have a cooling system that used CFCs or HCFCs (chlorofluorocarbons or hydrochlorofluorocarbons). CFCs and HCFCs are believed to harm stratospheric ozone if released to the atmosphere. Other refrigerants may also cause harm to the environment if released to the atmosphere.

If disposing of an old refrigerator, make sure the refrigerant is removed for proper disposal by a qualified technician. Intentionally released refrigerant may subject one to fines and imprisonment under provisions of environmental legislation.

## Electrical information

- The refrigerator must be plugged into its own dedicated 115 Volt, 60 Hz., 15 Amp, AC only electrical outlet. The power cord of the appliance is equipped with a three-prong grounding plug for protection against electrical shock hazards. It must be plugged directly into a properly grounded three prong receptacle. The receptacle must be installed in accordance with local codes and ordinances. Consult a qualified electrician. Avoid connecting refrigerator to a Ground Fault Interrupter (GFI) circuit. Do not use an extension cord or adapter plug.
- If the power cord is damaged, it should be replaced by an authorized service technician to prevent any risk.
- Never unplug the refrigerator by pulling on the power cord. Always grip the plug firmly, and pull straight out from the receptacle to prevent damaging the power cord.
- Unplug the refrigerator before cleaning and before replacing a light bulb to avoid electrical shock.
- Performance may be affected if the voltage varies by 10% or more. Operating the refrigerator with insufficient power can damage the compressor. Such damage is not covered under the warranty.
- Do not plug the unit into an electrical outlet controlled by a wall switch or pull cord to prevent the refrigerator from being turned off accidentally.

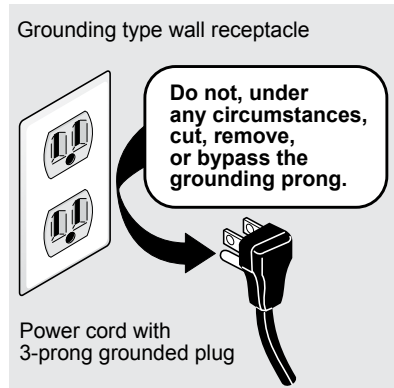

# 6

## FEATURES

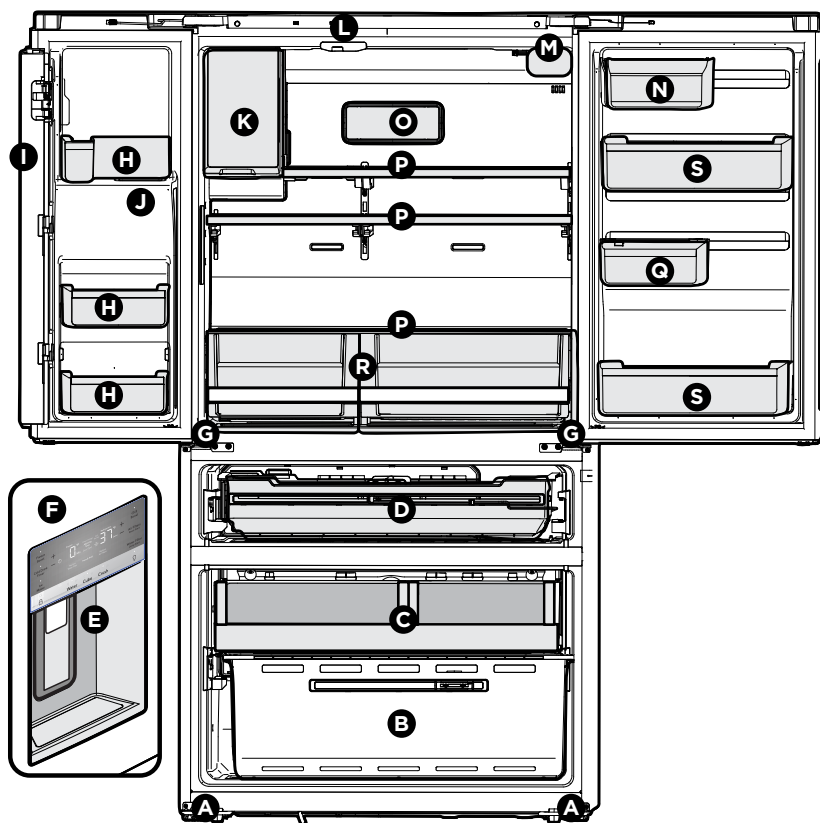

A	Anti-tip Leg
B	Lower Freezer Basket
C	Upper Freezer Basket
D	Custom-Flex™ Temp Drawer
E	Ice/Water Dispenser
F	External Appliance Control Display
G	Adjustable Hinges
H	Door Bin
I	Flipper Mullion

J	Ice Chute
K	Ice Maker
L	Flipper Guide
M	Water Filter
N	Dairy Compartment
O	Air Filter
P	Shelves
Q	Adjustable Door Bin
R	CrispSeal® Fresh Crispers
S	Gallon Door Bins



### IMPORTANT

Accessories are available for refrigerator and can be purchased at [Frigidaire.com](http://Frigidaire.com) or by calling 1-800-374-4432.

## Tools Necessary:

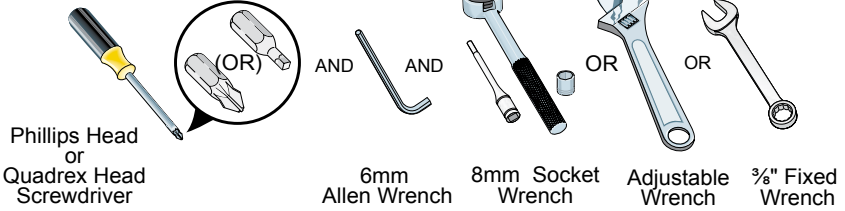

This Use & Care Manual provides general installation and operating instructions for this model. We recommend using a service or kitchen contracting professional to install the refrigerator. Use the refrigerator only as instructed in this Use & Care Manual. **Before starting the refrigerator, follow these important first steps.**

## Location

- Choose a place near a grounded, non-GFCI, electrical outlet. **Do Not** use an extension cord or an adapter plug.
- If possible, place the refrigerator out of direct sunlight and away from the range, dishwasher, or other heat sources.
- You must install the refrigerator on a floor that is level and strong enough to support a fully loaded refrigerator.
- Consider water supply availability for models equipped with an automatic ice maker.



## WARNING

This appliance is intended for use in residential household and similar interior applications such as:

- a kitchen/kitchenette
- a pantry room
- a basement
- an enclosed garage
- other interior residential-type environments



## CAUTION

Do Not install the refrigerator where the temperature will drop below 55°F (13°C) or rise above 110°F (43°C). The compressor will not be able to maintain proper temperatures inside the refrigerator.



## WARNING

### Installation

Allow the following clearances for ease of installation, proper air circulation, and plumbing and electrical connections:

Sides & Top	$\frac{3}{8}$ " (9.5 mm)
Back	1" (25.4 mm)



## NOTE

If you place the refrigerator with the door hinge side against a wall, allow additional space so you can open the door wider.

## Door opening

Position the refrigerator to allow easy access to a counter when removing food. For best use of the refrigerator drawers and freezer baskets, position the refrigerator where you can fully open both.

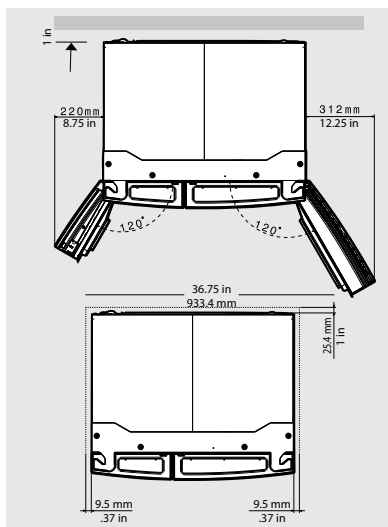

## Cabinet Leveling & Refrigerator Door Alignment (if necessary)

Guidelines for final positioning of refrigerator:

- Rest all 4 corners of the cabinet firmly on the floor.
- Slightly elevate the front to ensure the doors close and seal properly.
- Align and level the doors with each other.

Meet most of these conditions by raising or lowering the adjustable anti-tip legs.

To level the cabinet using the anti-tip legs:

1. Slightly open freezer drawer.
2. Lower anti-tip legs until they are both touching the floor. Use a pair of pliers to adjust.

**To raise unit:** turn leg clockwise (as shown).

**To lower unit:** turn leg counterclockwise.

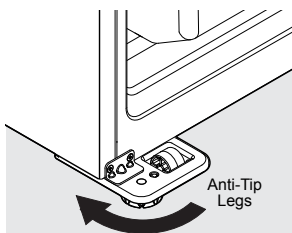

3. Ensure both doors are bind-free with their seals touching the cabinet on all 4 sides and that the cabinet is stable.

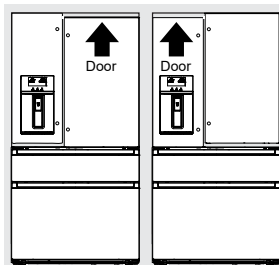

To make final door height adjustments:

1. Open Custom-Flex Temp drawer to make the lower hinge visible.
2. Insert 6 mm Allen™ wrench into the shaft of the lower hinge.

**To lower door:** turn the adjustment screw clockwise.

**To raise door:** turn the adjustment screw counterclockwise (as shown below).

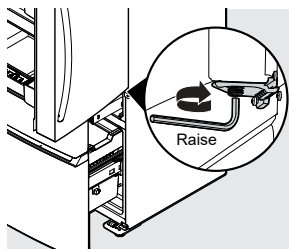

## Flipper Mullion

Adjust the flipper mullion for proper connection with the mullion guide by ensuring the flipper mullion is folded and perpendicular to the fresh food door. If the mullion guide is not in the correct position, it could prevent the door from closing completely.

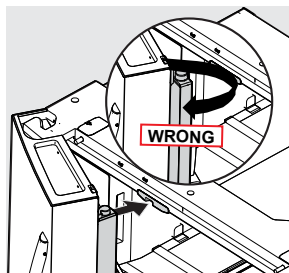



## Getting through narrow spaces

If refrigerator will not fit through an entrance area, you can remove the doors. Check first by measuring the entrance.

### To prepare for removing the doors:

1. Unplug the electrical power cord from the wall outlet.
2. Remove any food from the door shelves and close the doors.

### To remove the refrigerator doors:

1. Open doors to 90°.
2. Remove all 5 Phillips™ screws from top hinge cover and lift up. You can easily access 3 Phillips screws. You can access the other 2 screws by removing the 2 panels from the top hinge cover as shown.

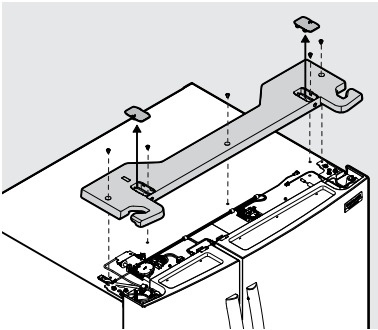

3. Trace lightly around the door's top hinges with a pencil. This makes reinstallation easier.
4. Disconnect any electrical harnesses running from the doors to the hinge cover.

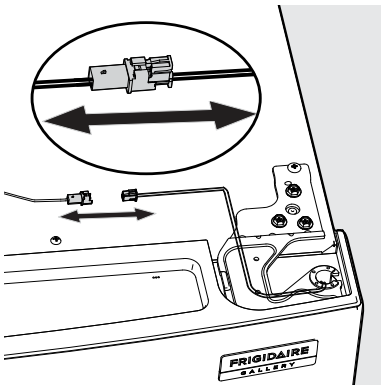

5. Pull up on water line gently to remove from door.

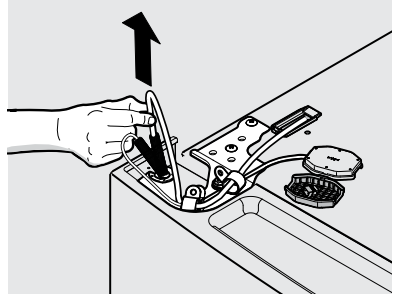

### NOTE

Use care while pulling the water tube from the door to be sure the tube does not kink.

### NOTE

You will pull approximately 4' of water tube from the refrigerator door.

### CAUTION

Be sure doors are set aside in a secure position where they cannot fall and cause personal injury, or damage to the doors or handles.

6. Remove three 8 mm bolts from both top hinges. Lift doors up off lower hinges and carefully set aside.

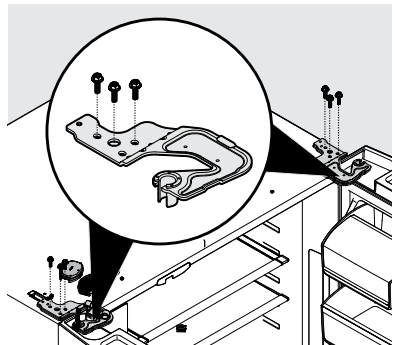

# 10 DOOR REMOVAL

7. In certain circumstances, you may need to remove the lower hinges for clearance purposes. To gain access to the lower hinges, first extend the Custom-Flex Temp Drawer. Unscrew the 3 lower hinge screws and slide the hinge inward.

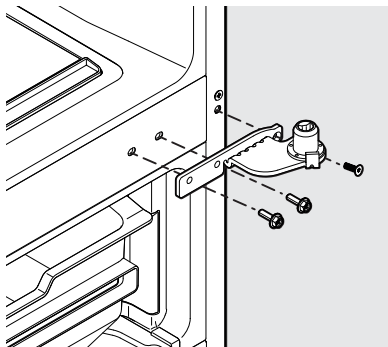

Lower Hinge Removal

8. To reinstall the doors, reverse the procedure.



## IMPORTANT

Make sure the water line tubing goes through the hole at the top of the dispenser pocket. A metal wrap on the tubing prevents damage from the hinge rubbing against it. You need to fix this back around the tube in the proper location upon reinstallation to protect the tube from the hinge.

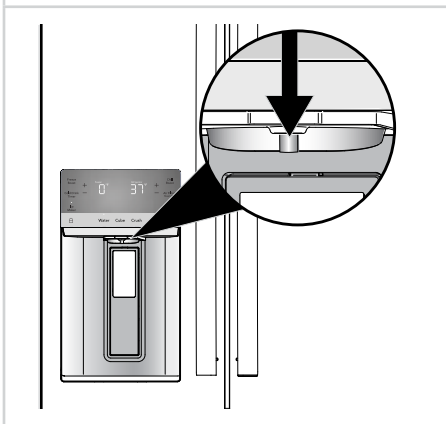

## NOTE

When reinserting the water tube and replacing the top hinge cover, carefully ensure the tube does not kink.

Once both doors are in place, ensure they are aligned with each other and level (Reference **INSTALLATION** for more details), and replace the top hinge cover.

## To remove the Custom-Flex Temp Drawer

1. Fully open the drawer.
2. Remove the basket from the drawer.

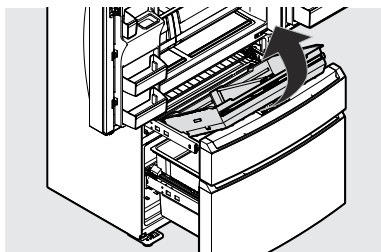

3. Unsnap the 4 cable ties by pressing clip sides together and pushing them through the opening.

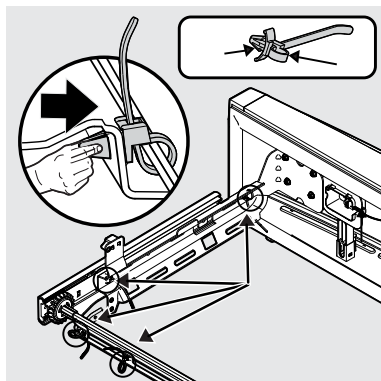

4. Remove the screw and the retaining clip and disconnect the harness

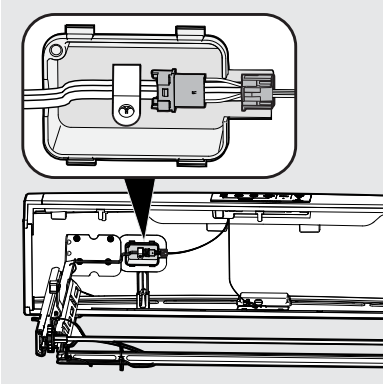

2. Reconnect the cabinet harness.
3. Replace the retaining clip and secure it with the screw.

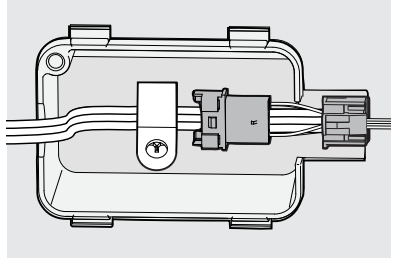

5. Remove the drawer by pressing on the liner clips and slide the rail past the clips on both sides to fully remove drawer from cabinet.

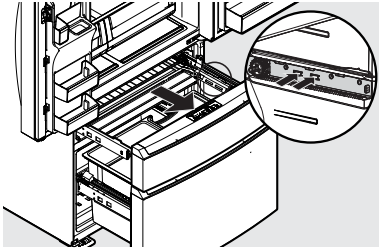

4. Reattach the electrical harness by positioning the cable clips over the black markings on the harness and push the 4 cable clips through the openings in the rail to secure the harness in place.

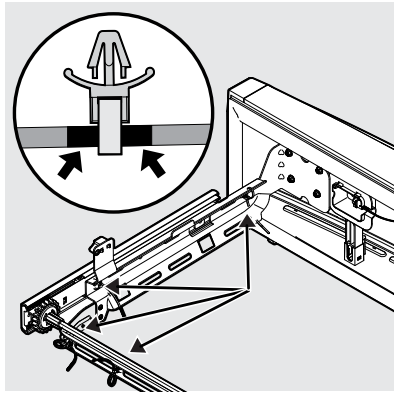

## Reinstalling the Custom-Flex Temp Drawer

1. Place the drawer with the brackets and sliders inside the compartment and click the sliders into place on each side.

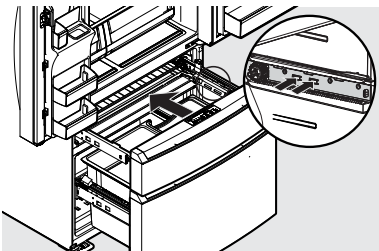

5. Slide the basket into place.
6. Close the drawer.

# 12 DOOR REMOVAL



## CAUTION

Drawer is heavy. Use caution when lifting.

## Removing Freezer Drawer

1. Open the drawer and fully extend it.
2. Remove the upper freezer drawer.
3. Remove the lower freezer basket.
4. Inside the cabinet, press the 2 tabs on both sides to release the sliders.
5. Remove the drawer with brackets and sliders.

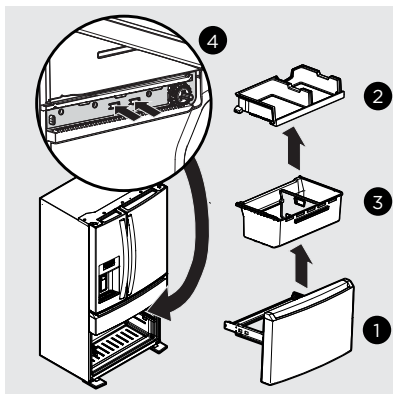

## Reinstalling Freezer Drawer

1. Place the drawer with brackets and sliders inside the cabinet and click into place.
2. Replace the lower freezer basket first, and then the upper freezer basket. Ensure the upper freezer basket rollers are seated correctly into the tracks before closing the freezer drawer.



## NOTE

For additional instructions, see **STORAGE FEATURES**.

**CAUTION**

Wear gloves and safety goggles. Use extreme CAUTION when installing these handles.

**Door Handle Mounting Instructions**

1. Remove the handles from the carton and any other protective packaging.
2. Position the fresh food handle end caps over the upper and lower pre-installed shoulder bolts (A) fastened into door, ensuring the holes for the set screws are facing toward the opposite door.
3. While holding the handle firmly against door, fasten the upper and lower Allen set screws (B) with the supplied Allen wrench.
4. Repeat steps 2 and 3 to install opposite handle. Ensure the holes for the set screws are facing toward the first door.

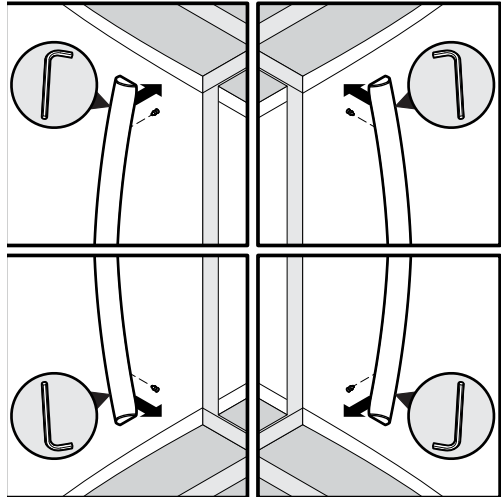
**Mounting Refrigerator Handles****NOTE**

When tightening the Allen set screws, you must apply force to the longer arm of the Allen wrench supplied in the handle packaging.

**NOTE**

Tighten all set screws so the screw is below the surface of the handle. Draw the handles tight to the doors/drawer with no gaps. Open the opposite door while tightening the Allen screw to make installation easier.

The door handle may loosen over time if you installed it improperly. If this happens, tighten the set screws on the handles.

# 14 WATER SUPPLY CONNECTION



## WARNING

To avoid electric shock, which can cause death or severe personal injury, disconnect the refrigerator from electrical power before connecting a water supply line to the refrigerator.



## CAUTION

To Avoid Property Damage:

- We recommend copper or stainless Steel braided tubing for the water supply line. We do not recommend using water supply tubing made of ¼ in. plastic. Plastic tubing greatly increases the potential for water leaks, and the manufacturer will not be responsible for any damage if you use plastic tubing for the supply line.
- DO NOT install water supply tubing in areas where temperatures fall below freezing.
- Chemicals from a malfunctioning water softener can damage the ice maker. If a water softening system is present, ensure you maintain the softener and it is working properly.



## IMPORTANT

Ensure the water supply line connections comply with all local plumbing codes.

**To install the water supply line, you need the following:**

- Basic Tools: adjustable wrench, flat-blade screwdriver, and Phillips screwdriver
- Access to a household cold water line with water pressure between 30 and 100 psi.
- A water supply line made of ¼" (6.4 mm) OD, copper or braided stainless steel tubing. To determine the length of tubing needed, measure the distance from the main water inlet valve at the back of the refrigerator to the cold water pipe. Then add approximately 6' (1.8 m), so you can move the refrigerator out for cleaning.

- A shutoff valve to connect the water supply line to the household water system. DO NOT use a self-piercing type shutoff valve.
- Do not reuse compression fitting or use thread seal tape.
- A compression nut and ferrule (sleeve) for connecting a copper water supply line to the main water inlet valve.



## NOTE

Check with local building authority for recommendations on water lines and associated materials prior to installing refrigerator. Depending on local/state building codes, we recommend for homes with existing valves its **Smart Choice®** water line kit 5304437642 with a 6' (1.8 meters) braided Stainless Steel Water Line. Please refer to [Frigidaire.com](http://Frigidaire.com) for more information.



## NOTE

Expect the first ice harvest within the first 24 hours of unit operation. To prevent any issues concerning ice production, please ensure you prime all water lines. See **Priming the water supply system** in the **AUTOMATIC ICE AND WATER DISPENSER** section.



## IMPORTANT

The refrigerator's water supply system includes several tubing lines, a water filter, and a water valve. To ensure the water dispenser works properly, completely fill this system with water when you first connect the refrigerator to the household water supply line.

Connection to Household Water Supply with 1/4" compression fitting

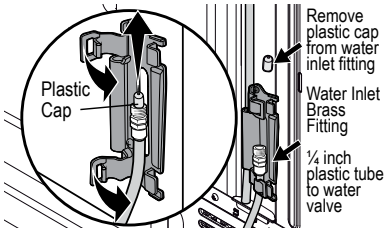
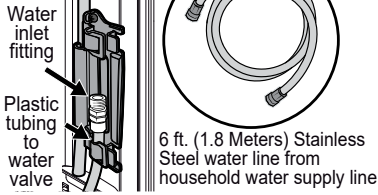

## To Connect Water Tube to Household Water Supply

1. Disconnect refrigerator from electrical power source.
2. Place the end of the water supply line into a sink or bucket. Turn ON the water supply and flush the supply line until the water is clear. Turn OFF the water supply at the shutoff valve.

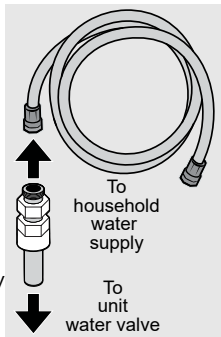

3. Open the locking clips and grab the water line coming from the refrigerator. Remove the plastic cap from the water inlet fitting and discard the cap.
4. If using (recommended) stainless steel braided tubing - the nut and ferrule are already assembled on the tubing. Slide the compression nut onto the water inlet fitting and finger tighten.
5. Using 1/2" and 7/16" wrenches (one to hold the household water line nut and the other to hold the water inlet fitting nut), tighten a half turn with the wrench. DO NOT over tighten.

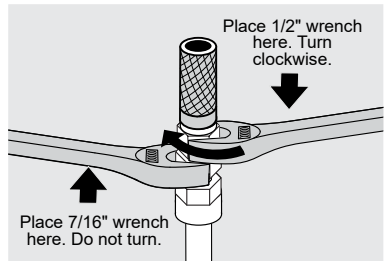
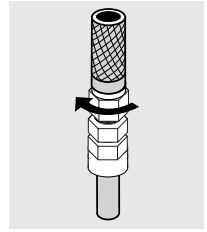

6. Replace the connected tubes into the clips and lock the clips back in place to keep the tubing in the right position.
7. Turn ON the water supply at the shutoff valve and tighten any leaky connections.
8. Reconnect refrigerator to an electrical power source.
9. Ensure the ice maker is turned ON.
10. Purge air from the Ice and Water Dispenser System by operating the water dispenser for 3-4 minutes. This will require dispensing several glasses of water.

# 16

## CONTROLS AND SETTINGS

### Sleep Mode Display

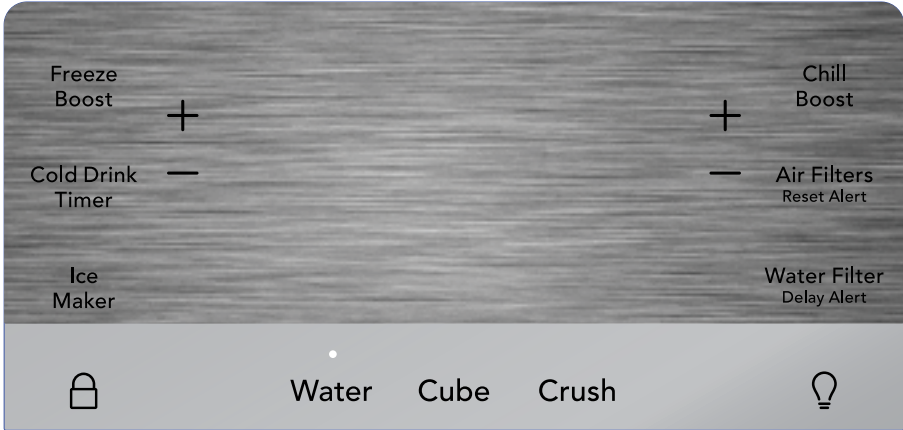

#### Sleep Mode

As a default, the display will go to sleep after a short time. If you press any icon, you will awaken the display. After a short time, it will go back to sleep. When in sleep mode, wake up the display to confirm the ice maker is On/Off. Turn off sleep mode to have the display on full time (awake mode). When sleep mode is Off, the display will always illuminate. To turn sleep mode On/Off, simultaneously press and hold **Crush** and  for 5 seconds. A tone will confirm.

### Awake Mode Display

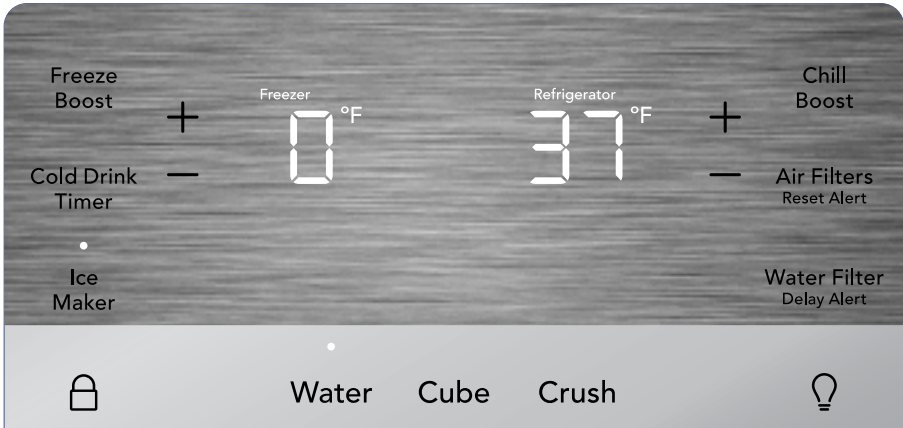

#### Awake Mode

To change from sleep mode (on) to awake mode (off), simultaneously press and hold **Crush** and  for 5 seconds. The display will show the current temperature/ice maker status. A tone will confirm.



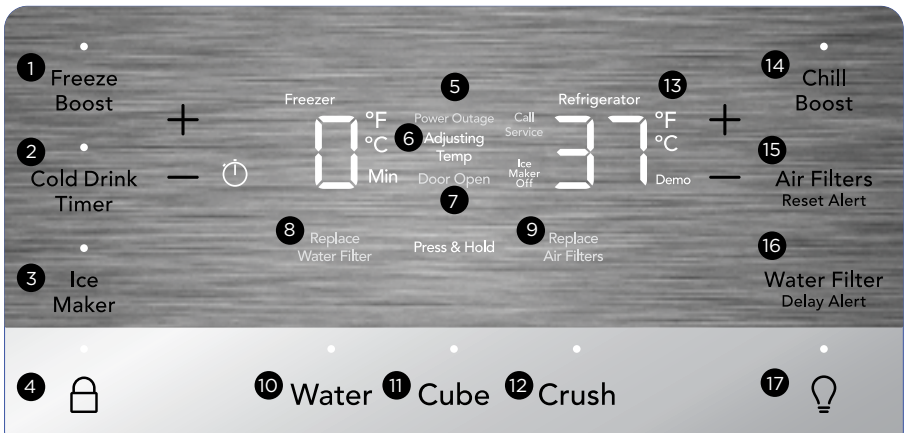

### 1 Freeze Boost (on/off)

Prior to grocery shopping, activate Freeze Boost so newly purchased food designated for the freezer will be preserved as quickly as possible. It automatically deactivates after 12 hours.

### 2 Cold Drink Timer

Quickly chills a drink inside the freezer compartment. To enable, touch **Cold Drink Timer**. A time value (in minutes) will appear on the freezer temp display and can be changed using the **+/-** buttons. A tone will sound when you input the time. The range is from 20-45 minutes in 5 minute intervals. Drinks will freeze if the temperature setting is too low or the timer setting is too long.



## WARNING

When using the **Cold Drink Timer**, make sure to remove drinks from freezer compartment when the alarm sounds. Carbonated drinks may explode if left in the freezer for too long.

### 3 Ice Maker

Press and hold for 3 seconds to turn the ice maker on/off. When the indicator is lit, the ice maker is on. When the ice maker is OFF, the **Ice Maker Off** indicator is lit. When the ice maker is OFF, it stops making ice. When you enable the sleep mode, wake the display to confirm the ice maker is on/off (see **Sleep Mode** section). While off, you can continue dispensing ice as long as ice is in the bucket. When the ice maker is off and ice is dispensing, the indicator above **Ice Maker** and **Ice Maker Off** both blink.



4 Use the lock button to lock the display preventing it from being used in certain situations. Press and hold for 3 seconds to enable/disable. While locked, you can make no changes to settings on the display. Dispensing ice and water are disabled. The indicator will flash and an audible warning will sound.

### 5 Power Outage

In the event of a power failure, **Power Outage** illuminates once you restore power and a tone sounds. The alert only illuminates if the refrigerator or freezer reached unsafe temperatures during the outage. Press any button to silence the tone.

- 6 Adjusting Temp**  
Illuminates when you change temperatures on the display and will remain illuminated until the desired temperatures are reached inside the refrigerator and freezer. Press either the **+** or **-** to adjust to desired temperature setting.

**Freezer temp**

Control temperatures range from -6°F / -21°C to +6°F / -15°C.

**Refrigerator temp**

Control temperatures range from +34°F / +1°C to +44°F / +7°C. This unit is designed to operate at 37°F Refrigerator/0°F Freezer. The unit should stabilize temperatures within 24 hours of installation.

- 7 Door Open**  
Illuminates whenever you open the doors. If you leave a door open for 5 minutes or more, an alarm will sound and the display will illuminate until you shut the door. Pressing any button mutes the alarm temporarily. Check to make sure no food is blocking the doorway.

- 8 Replace Water Filter**  
Illuminates every 6 months or when the filter needs replacing. After you replace with an authentic filter and complete the authentication process, the warning on the display should disappear. See **FILTER REPLACEMENT** for more information.

- 9 Replace Air Filters**  
Display illuminates every 6 months or when filter needs replacing. Replace the filter and then press and hold **Reset Air Filter** for 3 seconds to deactivate warning on display. See **FILTER REPLACEMENT** for more information.

- 10 Water**  
Press **Water** to dispense water. An indicator light illuminates above the active feature.

- 11 Cube**  
Press **Cube** to dispense cubed ice. An indicator light illuminates above the active feature.

- 12 Crush**  
Press **Crush** to dispense crushed ice. An indicator light illuminates above the active feature.

- 13 °F/°C**  
To toggle between Fahrenheit (°F) and Celsius (°C), simultaneously press and hold **+** and **-** for 5 seconds on the refrigerator side of display.

- 14 Chill Boost**  
**Chill Boost** is a faster rate for chilling food in the refrigerator compartment. Use this feature when loading several items into the refrigerator at one time. It deactivates after 6 hours.

- 15 Reset Air Filters**  
After replacing the filter, press and hold for 3 seconds to reset.

- 16 Water Filter**  
Your appliance is equipped with an electronically authenticated water filter. If an error relating to authentication occurs, press and hold **Water Filter** for 3 seconds to delay the alert. See **FILTER REPLACEMENT** for more information.

- 17**  Toggles dispenser light On and Off. Press and hold for 5 seconds to enable ambient lighting. Once enabled, press and hold for 2 seconds to disable ambient lighting

 **NOTE**

The recommended settings for a product installed in a kitchen is 37°F for the fresh food compartment and 0°F for the freezer.

 **IMPORTANT**

If food is freezing in the fresh food compartment, increase the temperature setting 1 or 2 degrees.

 **IMPORTANT**

Placing food within 1" in front of the air ports may cause food to freeze.

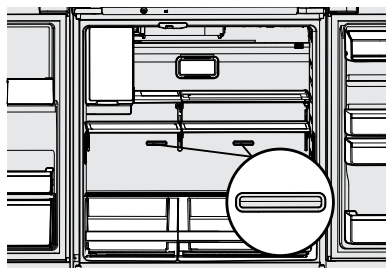

**NOTE**

Control features and alarms may vary by model.

**Alarms****Power Outage**

In the event of a power failure, the power outage alert will illuminate once power has been restored and a tone will sound. The alert will only illuminate if the refrigerator or freezer reached unsafe temperatures during the outage. Press any button to silence the tone.

**Water Filter**

When illuminated, you need to replace the water filter. Change the water filter every 6 months or when 125 gallons of water has been dispensed. Once you have replaced the filter with a genuine authentic filter, the alert should disappear after 30 seconds. A tone will sound once you have reset it.

**Air Filter**

When illuminated, you need to replace the air filter. Change the air filter every 6 months. To reset, press and hold **Air Filter** for 3 seconds. A tone will sound once you have reset it.

**Door**

If you leave a door open for 5 minutes or more, an alarm sounds and the door open indicator illuminates on the display. Turn the alarm off by closing the door or pressing any key. The appliance control display will return to normal operations after you close the door.

**High Temperature**

In the event of a high temperature condition, an alarm sounds. The appliance control display will show **HI** on whichever compartment the alarm is detected. An alarm sounds for at least 10 seconds until you acknowledge the alert. Reset this alarm by touching any key or opening a door.

**Sabbath Mode**

The Sabbath Mode disables portions of the refrigerator and its controls in accordance with observance of the weekly Sabbath and religious holidays within the Orthodox Jewish community.

Sabbath Mode is turned ON and OFF by simultaneously pressing and holding both the **FZ-** and **FF+** for 5 seconds. Other than the High Temp alarm, no audible sounds occur until you exit the Sabbath mode. The display shows **Sb** while in Sabbath Mode.

In the Sabbath Mode, the High Temp alarm is active for health reasons. For example, if you leave the door ajar, the High Temp alarm activates. The refrigerator functions normally, once you close the door, without any violation of the Sabbath/Holidays. The High Temp alarm sounds when the cabinet temperature is outside the safe zone for 20 minutes. The alarm silences itself after 10 minutes while the High Temp icon stays lit until you exit the Sabbath Mode.



For further assistance, guidelines for proper usage and a complete list of models with the Sabbath feature, please visit the web at [star-k.org](http://star-k.org).

**NOTE**

While in Sabbath Mode, neither the lights, dispenser, nor the appliance control display will work until you deactivate the Sabbath Mode.

Refrigerator stays in Sabbath Mode after power failure recovery. You must deactivate it with the buttons on the appliance control display.

**NOTE**

Although you have initiated the Sabbath Mode, the ice maker will complete the cycle it had already started. The ice cube compartment remains cold and you can make new ice cubes with standard trays.

### Using the ice maker after installation

Before making ice for the first time, be sure to prime the water supply system. Air in new plumbing lines can result in two or three empty ice maker cycles. Furthermore, if the system is not flushed, the first ice cubes may be discolored or have an odd flavor.

### Priming the water supply system

Before dispensing water for the first time, be sure to prime the water supply system. If the system is not flushed, the first glasses of water may have discolored water or have an odd flavor.



### CAUTION

For proper dispenser operation, recommended water supply pressure should fall between 30 psi and 100 psi. Excessive pressure may cause the system to malfunction.

1. Hold a glass against the paddle for about 4 minutes to purge air from the system.
2. Continue dispensing at least 1 full gallon (3.6 L) of water and discard.

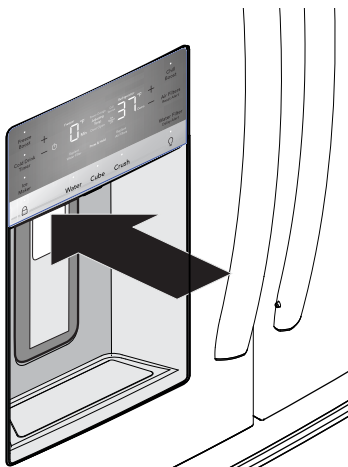

Dispenser



### NOTE

The water dispenser has a built-in device that shuts off the water flow after two minutes of continuous use. To reset this shutoff device, simply release the dispenser paddle.



### NOTE

After the initial 26 oz (750 ml), water will remain room temperature until the tank has refilled and been given enough time to chill the next 26 oz (750 ml) of water. May take up to 8 hours to chill.

### Ice Maker Operation & Care

After the refrigerator is installed properly and has cooled for several hours, the ice maker can produce ice within 24 hours. The ice maker will fill the ice bin from the rear. Dispense some ice to force the ice forward in the bin. This will allow the bin to fill completely.

### Ice Maker and Storage Bin Capacity

Both counter depth and standard depth model ice makers should produce 3.2 to 3.7 lbs of ice per 24 hours depending on usage conditions. The counter depth ice bin will hold about 4 lbs of ice, and the standard depth ice bin will hold about 5 lbs of ice.

### Turning the ice maker on and off



### IMPORTANT

The ice maker is turned on at the factory so it can work as soon as the refrigerator is installed. If it is not possible to connect a water supply, set the ice maker's On/Off feature to Off either by using the display or by pressing the switch (features vary by model). Otherwise, the ice maker's fill valve may make a loud chattering noise when it attempts to operate without water.

Press and hold **Ice Maker** on the external appliance control display for 3 seconds to turn ice production on and off.



## NOTE

The ice maker also has a built-in plastic signal arm that automatically stops ice production when the ice bin is full. This signal arm should not be used to manually stop the ice maker.



## IMPORTANT

Turning off the ice maker simply disables ice making. Existing ice can still be dispensed, and water can be dispensed.



## IMPORTANT

On occasion, unusually small ice cubes may be noticed in the bucket or in dispensed ice. This could occur in normal operation of the ice maker. If happening frequently, it may be an indication of low water pressure or the water filter needs to be replaced. As the water filter nears the end of its useful life and becomes clogged with particles, less water is delivered to the ice maker during each cycle. Remember, if it's been six months or longer since last changing the water filter, replace it with a new one. Poor quality household water may require the filter to be changed more frequently.



## CAUTION

If the water supply to the refrigerator is softened, be sure the softener is properly maintained. Chemicals from a water softener can damage the ice maker.

## Ice maker/dispenser tips

- If refrigerator is not connected to a water supply or the water supply is turned off, turn off the ice maker as described in the previous section.
- The following sounds are normal when the ice maker is operating:
  - Motor running
  - Ice dropping into ice bin
  - Water valve opening or closing
  - Running water
- If a large quantity of ice is needed at one time, it is best to get cubes directly from the ice bin.
- Ice cubes stored too long may develop an odd flavor. Empty the ice bin as explained below.
- When dispensing cubed ice, it is normal to have a small quantity of little pieces along with the whole cubes.
- To avoid splashing, dispense ice into the container before adding liquids.
- It is normal for ice to fill to the top of the ice bin.

## Cleaning the ice maker

Clean the ice maker and ice bin at regular intervals, especially prior to vacation or moving.

1. Turn off the ice maker using the button on the display.
2. Remove the ice bin by lifting upward and pulling straight out.
3. Empty and carefully clean the ice bin with mild detergent. Do not use harsh or abrasive cleaners. Do not place in dishwasher. Rinse with clear water.
4. Allow the ice bin to dry completely before replacing in the freezer.
5. Replace the ice bin. Turn the ice maker on.

**Remove and empty the ice bin if:**

- An extended power failure (one hour or longer) causes ice cubes in the ice bin to melt and refreeze together after power is restored, jamming the dispenser mechanism.
- The ice dispenser is used infrequently. Ice cubes will freeze together in the bin, jamming the dispenser mechanism. Shake the bin to loosen the cubes, or clean as explained above.

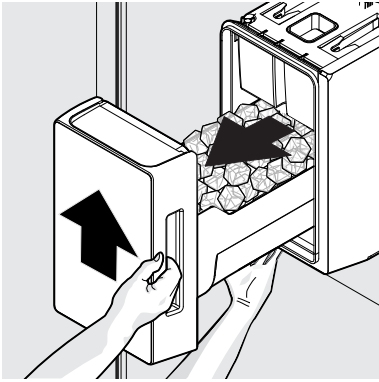
**Removing Ice Bin****CAUTION**

NEVER use an ice pick or similar sharp instrument to break up the ice. This could damage the ice bin.

To loosen stuck ice, use warm water. Before replacing the ice bin, make sure it is completely dry.

**CAUTION**

To avoid personal injury or property damage, handle tempered glass shelves carefully. Shelves may break suddenly if nicked, scratched, or exposed to sudden temperature change. Allow the glass shelves to stabilize to room temperature before cleaning. Do not wash in dishwasher.

**NOTE**

Features may vary according to model.

Shelf positions can easily be adjusted in the fresh food compartments as needed. The shelves have mounting brackets that attach to slotted supports at the rear of each compartment.

**Change the Position of a Shelf**

1. Remove all food from the shelf.
2. Lift the front edge up and pull the shelf out.
3. Replace by inserting the mounting bracket hooks into the desired support slots.
4. Lower the shelf and lock it into position.

**To adjust the flip shelf:**

1. Remove food from shelf.
2. Lift the right side edge of shelf upwards and push to the left towards ice maker.

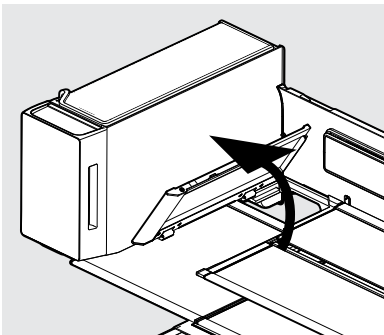

Flip Shelf

**To adjust slide-under shelf:**

1. Push front half shelf backward toward the rear of the cabinet until the rear half shelf drops down, and then gently continue pushing the front half shelf back and under the rear half shelf.

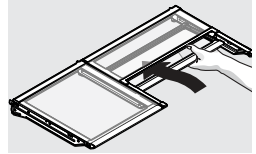

Slide-Under Shelf

**Drawers**

The refrigerator includes a variety of storage drawers.

**CrispSeal Fresh Crisper**

Use our crisper to keep your produce fresh for longer, or flip it around to use as an open compartment to easily access items such as beverages, yogurts or snacks.

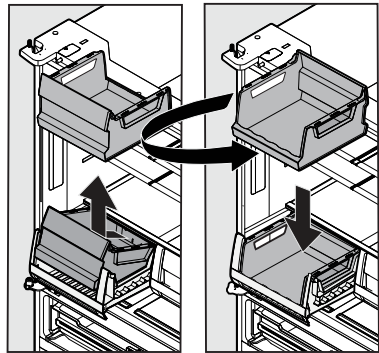
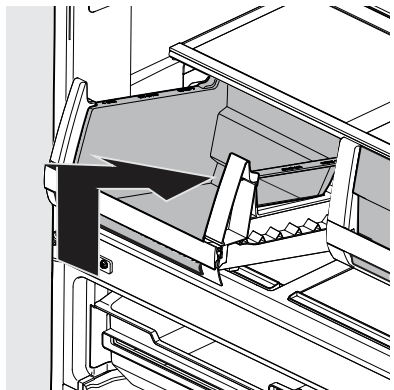
**Flexible Storage with our Reversible Bin**

Angle the bin up to reinstall

# 24 STORAGE FEATURES

## To remove the CrispSeal Fresh drawer for cleaning:

1. Pull the drawer out until it stops.
2. Lift the front slightly and remove the drawer.

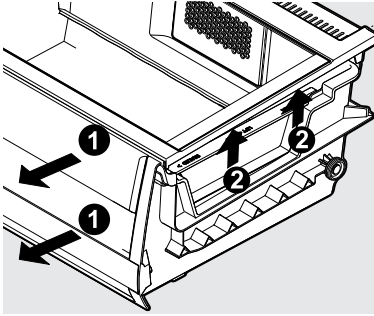

Removing CrispSeal Fresh Drawer

### NOTE

Remove the crisper insert and the Produce Keeper Plus filter before washing the crisper.

## To remove the auto humidity control membrane for cleaning:

1. Reach to back of humidity control cover.
2. Place fingers between the humidity control and the back wall, pull up on cover.
3. Pull cover toward the front of cabinet and remove.

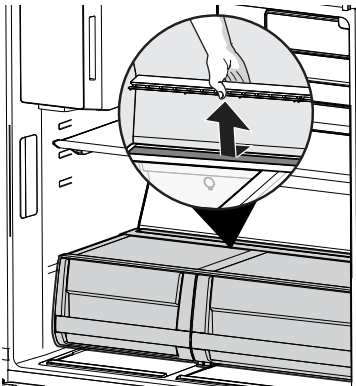

Removing Auto Humidity Control Membrane

4. Remove the humidity membrane from the housing by lifting up sliding over.

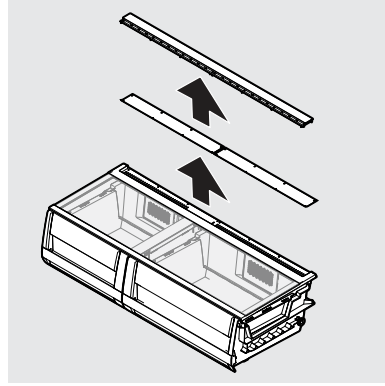

Removing Auto Humidity Control Membrane

5. Clean humidity membrane with hot soapy water.
6. Replace membrane in housing and unit by reversing the steps above.

### NOTE

Frigidaire does not recommend replacing the auto-humidity membrane unless it becomes damaged or ruined. If the membrane becomes soiled, it can be washed with soap and water. Ensure membrane is dry before replacing in unit.

## SnackZone - Recessed Snack Drawers

These drawers are ideal for storage of deli meats and cheeses.

**To open:** slide back the cover to allow access to the drawers.

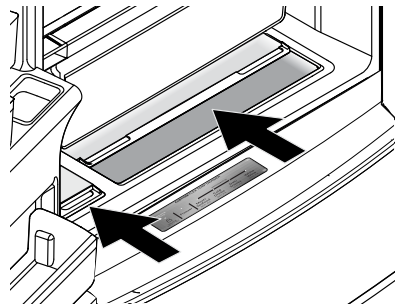

Opening SnackZone Recessed Snack Drawers



## CUSTOM-FLEX TEMP DRAWER



### IMPORTANT

Do not use the Custom-Flex™ Temp Drawer to store fresh produce as these items may freeze and cause damage to the fruits and leafy vegetables stored in the drawer.

### Using Your Custom-Flex Temp Drawer Controls

- 1 The drawer automatically defaults to a locked state to prevent any unwanted use. To change the drawer's settings, it first needs to be unlocked. To unlock, press and hold the **UNLOCK** icon for 3 seconds. It will automatically lock after 10 seconds without any interaction.



### CAUTION

Do not store glass bottles in the Custom-Flex Temp Drawer when the Temperature setting is in Freezer, Meat/Seafood, or Cold Drink modes. The glass may break and shatter, causing physical harm and injury.

### Freezer:

- 2 To change the drawer temperature when in the freezer temp setting, use the control panel display on the front door. Changing the temp on the display will change both the drawer temp setting **AND** the freezer compartment.

### Refrigerator:

- 3 Choosing **Meat/Seafood** will set drawer temperature to 28°F (-2°C). A tone will sound to confirm choice. Use this setting for short term storage. Any meat to be kept longer than two days should be frozen.
- 4 Choosing **Cold Drinks** will set drawer temperature to 32°F (0°C). A tone will sound to confirm choice.
- 5 Choosing **Deli/Snacks** will set drawer temperature to 37°F (3°C). A tone will sound to confirm choice.

- 6 Choosing **Chilled Wine** will set drawer temperature to 45°F (7°C). A tone will sound to confirm choice.

### Custom-Flex Temp Drawer Dividers

To position drawer dividers, slide left or right. For easier repositioning, dividers do not lock but instead use the weight of stored items to keep the dividers in place. Dividers may shift when opening/closing drawer when fewer items are stored.

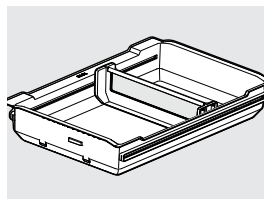

### Doors

#### Storage bins

The doors to the fresh food compartment use a system of modular storage bins. All of these bins are removable for easy cleaning. Bins can be adjusted as needed.

Door bins are ideal for storing jars, bottles, cans, and large drink containers. They also enable quick selection of frequently used items.

#### Adjustable door bins

Some models have adjustable door bins that can be moved to suit individual needs.

To adjust the collapsible door bin:

1. Make sure bin is securely seated on rail in door.
2. Grab one side of bin and place other hand on adjustable side.
3. Pull on side of bin until the bin is adjusted to desired width.



### NOTE

It can be difficult to pull out the collapsible bin. Some force may be required.

# 26 STORAGE FEATURES

## To move door bin side-to-side:

1. Tilt bin up so the back of the bin is off the door but the hook is still engaged.
2. Slide bin along rail to desired position.
3. Lower bin back into place.

## To move door bin up or down:

1. Lift bin up disengaging the hook.
2. Move bin to desired rail location.
3. Push bin hook into rail engaging the hook.

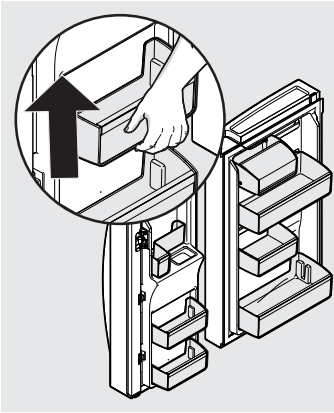

Adjustable Door Bins

## Freezer Features

### To remove upper freezer drawer:

1. Open freezer compartment completely.
2. Lift up and out to remove upper freezer drawer.
3. Reverse the steps to reinstall drawer.

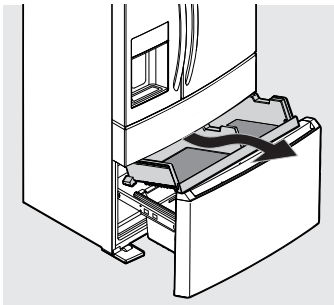

Freezer Drawer



## IMPORTANT

There are wheels on the bottom of the drawer. Make sure all wheels are aligned on their respective tracks for proper function. If drawer is not aligned properly, it will cause problems with the door operation.



## NOTE

If basket is not resting on stabilizer bar retainer clips, the drawer will not close properly.

### To remove freezer basket:

1. Open freezer compartment completely.
2. Lift the basket up and remove.
3. Reverse the steps to reinstall freezer basket.

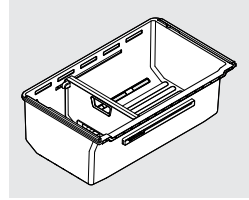

## Dividers

Grab hand hold on lower divider and pull up slightly to slide to next position. (The divider cannot be removed.)

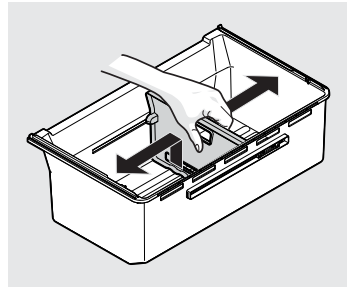

Plastic Lower Basket Divider

## Ideas for storing foods

### Fresh food storage

- Keep the fresh food compartment between 34°F and 44°F with an optimum temperature of 37°F.
- Avoid overcrowding the refrigerator shelves, which reduces air circulation and causes uneven cooling.
- Avoid placing food in front of air ports. (See **CONTROLS AND SETTINGS** for illustration.)

### Fruits and vegetables

- Store fruits and vegetables in crisper drawers, where trapped moisture helps preserve food quality for longer time periods.
- Do not wash items until ready to use. Remove excess water before placing inside unit.
- Wrap any items that have strong odors or high moisture content.

### Meat

- Wrap raw meat and poultry separately and securely to prevent leaks and contamination of other foods or surfaces.
- Use the Custom-Flex™ Temp Drawer to store meat/poultry for short-term storage. Any meat to be kept longer than two days should be frozen.

### Frozen food storage

- Keep the freezer compartment at 0°F (-18°C) or lower.
- A freezer operates most efficiently when it is at least ¾ full.

### Packaging foods for freezing

- To minimize food dehydration and quality deterioration, use aluminum foil, freezer wrap, freezer bags, or airtight containers. Force as much air out of the packages as possible and seal them tightly. Trapped air can cause food to dry out, change color, and develop an off-flavor (freezer burn).
- Wrap fresh meats and poultry with suitable freezer wrap prior to freezing.
- Do not refreeze meat that has completely thawed.

### Loading the freezer

- Prior to grocery shopping, activate **Freeze Boost** so newly purchased

food designated for the freezer will be preserved as quickly as possible.

- Activating **Freeze Boost** also will help the freezer more efficiently maintain the selected temperature after placing new purchases with pre-existing frozen foods.
- Avoid adding too much warm food to the freezer at one time. This overloads the freezer, slows the rate of freezing, and can raise the temperature of frozen foods.
- Leave a space between packages, so cold air can circulate freely, allowing food to freeze as quickly as possible.

## Ideas for saving energy

### Installation

- Locate the refrigerator in the coolest part of the room, out of direct sunlight, and away from heating ducts or registers.
- Do not place the refrigerator next to heat-producing appliances such as a range, oven, or dishwasher. If this is not possible, a section of cabinetry or an added layer of insulation between the two appliances will help the refrigerator operate more efficiently.
- Level the refrigerator so that the doors close tightly.

### Temperature settings

- Refer to **CONTROLS AND SETTINGS** for illustration and recommended settings.

### Food storage

- Avoid overcrowding the refrigerator or blocking cold air vents. Doing so causes the refrigerator to run longer and use more energy.
- Cover foods and wipe containers dry before placing them in the refrigerator. This cuts down on moisture build-up inside the unit.
- Organize the refrigerator to reduce door openings. Remove as many items as needed at one time and close the door as soon as possible.
- Do not place a hot container directly on a cold shelf. Remember, such an extreme temperature change may damage the glass.

## Understanding the sounds coming from the refrigerator

High-efficiency refrigerators may introduce *unfamiliar sounds*. These sounds normally indicate the refrigerator is operating correctly. Some surfaces on floors, walls, and kitchen cabinets may make these sounds more noticeable.

The following is a list of major components in the refrigerator and the *sounds* they can cause:

- A Evaporators** Refrigerant through the evaporators may create a *boiling or gurgling* sound.
- B Evaporator fans** Sounds of *air being forced through the refrigerator* by the evaporator fans may be heard.
- C Defrost heaters** During defrost cycles, water dripping onto the defrost heaters may cause a *hissing or sizzling* sound. After defrosting, a *popping* sound may occur.
- D Automatic ice maker** When ice has been produced, sounds of *ice cubes falling* into the ice bin may be heard. Ice maker fan, water valve activation, and refrigerant gas fluid may create sounds from its operation.
- E Electronic control & automatic defrost control** These parts can produce a *snapping or clicking* sound when turning the cooling system on and off.
- F Condenser fan** Sounds of *air being forced through the condenser* may be heard.
- G Compressor** Modern, high-efficiency compressors run much faster than previous models. The compressor may have a *noticeable hum or pulsating* sound during operation.
- H Water valves** Make a *buzzing* sound each time they open to fill the ice maker.
- I Drain pan** (not removable) Sounds of *water dripping* into the drain pan during the defrost cycle may be heard.
- J Condenser** May create minimal sounds from *forced air*.
- K Motorized damper** May produce a *light humming* during operation.

- L Ice dispenser** When dispensing ice, a *snapping, clicking, or popping* sound may be heard.

### NOTE

Energy efficient foam in the refrigerator is not a sound insulator.

### NOTE

During automatic defrost cycle, a red glow in the back wall vents of the freezer compartment is normal.

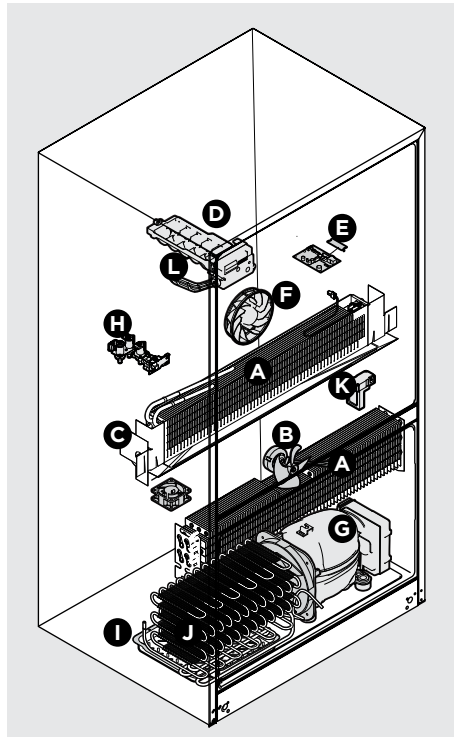

## PureAir® AF-2™ Air Filter (select models)

The air filter is located in the top center of the fresh food compartment.

### Replacing Your Air Filter

To ensure optimal filtering of refrigerator odors, change the air filter every 6 months (**Replace Air Filter** on the appliance control display indicates replacing the filter after 6 months).

1. Remove the air filter cover by squeezing the top and bottom of the cover together and removing from liner.
2. Remove the old filter and discard it.
3. Unpack the new filter and snap it into the filter cover. The open face (carbon media) of the filter should be installed facing outward in the cover.
4. Replace the air filter cover by squeezing the sides and snapping it back into place.
5. To reset, press and hold **Reset Air Filter** on the appliance control display for 3 seconds. Tone will sounds once it has been reset.

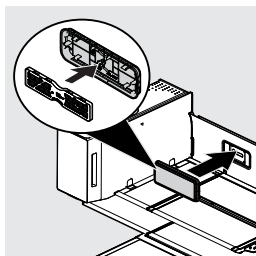

### Ordering Replacement Air Filters

Order replacement filters online at Frigidaire.com, by calling 1-800-374- 4432 or through the dealer from which the refrigerator was purchased. Frigidaire recommends replacing filters at least once every 6 months.

Here is the product number to request when ordering:

**PureAir AF-2 Air Filter**  
Part #FRGPAAF2

## PurePour Connect™ PWF-2™ Water Filter

The refrigerator is equipped with a water filtering system. The water filtering system filters all dispensed drinking water, as well as the water used to produce ice. The water filter is located at the top right side of the fresh food compartment.

### Accessing Your Water Filter

Change the water filter every 6 months to ensure the highest possible water quality. **Replace Water Filter** on the display indicates when to replace the filter after a standard amount of water (125 gallons/473 liters for **PurePour Connect PWF-2**) has flowed through the system.

If the refrigerator has not been used for a period of time (during moving for example), change the filter before reinstalling the refrigerator.

**To Remove:** Pull the cover forward and the cover will drop down and allow access to the filter. Push on the end/face of the filter to remove it from the unit and discard it.

**To Reinstall:** Push the cover up toward the liner, and then push it toward the rear of the cabinet. The filter cover will snap back into place.

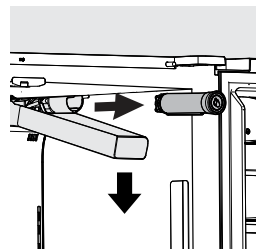

### Ordering Replacement Water Filters

Order replacement filters online at Frigidaire.com, by calling 1-800-374-4432 or through the dealer from which the refrigerator was purchased. We recommend replacing filters at least once every 6 months.

Here is the product number to request when ordering:

**PurePour Connect PWF-2**  
Part #FPPWFU02

### NOTE

When ordering replacement filters, please reorder the same filter type that is currently in the refrigerator.

# 30 FILTER REPLACEMENT

Keep safe, great-tasting water flowing with a **PurePour Connect PWF-2** water filter. Using a **PurePour Connect PWF-2** water filter:

- **Makes Safer Water Second Nature**  
**PurePour Connect PWF-2** water filters are certified to reduce contaminants\* and keep great-tasting water flowing for you and your family.
- **Produces Purity You Can Trust**  
Know for certain your **PurePour Connect PWF-2** water filter is a protector. Counterfeits and knockoffs put your refrigerator and health at risk. Frigidaire Genuine Filters are the smarter, safer choice.
- **Every Drop Gives Back**  
Partnered on sustainability efforts, the use of a **PurePour Connect PWF-2** water filter saves the cost of bottled water and cuts back on plastic.

\*For the complete list, please see Performance DataSheet on Frigidaire.com

## PurePour Connect PWF-2 Authentication

Your refrigerator contains a water filter authentication system to protect you from the harm that can occur when using counterfeit filters. We recommend you use only the **PurePour Connect PWF-2** water filter with this appliance. Using any other filter can cause an error (**Er FA**) to appear on the appliance control display.

Errors can occur:

- If an authentic expired filter is removed and reinserted into the appliance
- If an authentic, but incorrect filter is installed
- If a non-authentic filter is installed
- If the filter is not installed properly

In the cases above, the appliance control display may show an error code related to the filter authentication, and **Replace Water Filter** will appear on the display. You can still use dispensing functions while the error displays. You can temporarily dismiss the error twice by holding **Water Filter** for 3 seconds to delay the alert each time it appears. On the third appearance of the error, the error code permanently displays on the appliance control until you install a new authentic filter.

## More about the Advanced Water Filter



Tested and certified by NSF/ANSI Standards 42, 53, 401 and CSA B483.1 in **PurePour Connect PWF-2** systems for the reduction of claims specified on the performance data sheet.

Do not use with water that is microbiologically unsafe or of unknown quality without adequate disinfection before or after the system. Use systems certified for cyst reduction on disinfected waters that may contain filterable cysts.

### Test & certification results:

- Rated Capacity - 125 gal/453 L for **PurePour Connect PWF-2** ice and water filter
- Rated service flow - .50 gal/min.
- Operating Temp: Min. 33°F, Max. 100°F
- Maximum Rated Pressure - 100 lbs/in<sup>2</sup>
- Recommended Minimum Operating Pressure: 30 lbs/in<sup>2</sup>

### Replacing Your Water Filter:

It is not necessary to turn the water supply off to change the filter. Be ready to wipe up any small amounts of water released during the filter replacement.

1. Turn Off the ice maker(s).
2. Pull the water filter cover forward and the cover will drop down to allow access to the filter.
3. Remove the filter by pushing on the end/face of the filter (you should hear a click as the cartridge disengages the snap-in connector).
4. Slide the old water filter cartridge straight out of the housing and discard it.
5. Unpack the new filter cartridge. Remove the 2 clear plastic cap covers on the filter connector. Using the alignment guide, slide the filter gently into the filter housing until it stops against the snap-in connector at the back of the housing.
6. Push firmly until the cartridge snaps into place (you should hear a click as the cartridge engages the snap-in connector).

7. Press a drinking glass against the water dispenser while checking for any leaks at the filter housing. Any spurts and sputters that occur as the system purges air out of the dispenser system are normal.
8. Push the cover up toward the liner. Then push the filter cover toward the rear of the cabinet. The filter cover will snap back into place.
9. After filling one glass of water, continue flushing the system for about 4 minutes. See **Priming the water supply system** for more information.
10. Once you have properly installed the filter, the authentication process may take up to 30 seconds to complete. After authentication is complete, the filter status on the display will automatically update based on the condition of the filter.
11. Turn on the ice maker(s).

## PureAir PK-2 Produce Keeper Plus™

Keep fruits and vegetables fresher longer with **PureAir Produce Keeper Plus**. Our produce keeper absorbs ethylene gas, the natural gas that causes produce to ripen quicker. Reduce food waste, save money and enjoy fresh-tasting produce with a longer storage life.

### Ordering Replacement Filters

Order replacement filters online at [Frigidaire.com](http://Frigidaire.com), by calling 1-800-374-4432 or through the dealer from which the refrigerator was purchased. Frigidaire recommends replacing filters at least once every 12 months.

Here is the product number to request when ordering:

### PureAir Produce Keeper Plus

Part # **FRPAK2RF™**

### Installing the PureAir Produce Keeper Plus:

1. Remove the plastic wrapper. Insert the packet into the holder in the rear of the Crisper.
2. For optimal results, replace the refill every 12 months along with your air filter.

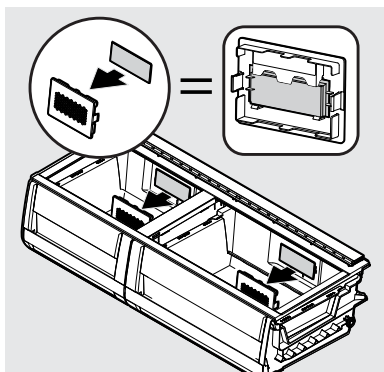
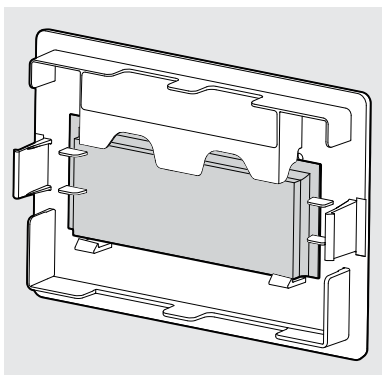

### CAUTION

**DO NOT OPEN CLOTH POUCH.** Keep out of the reach of children.

**DO NOT EAT.** If ingested, seek medical treatment immediately.

**WASH HANDS AFTER HANDLING.**

**DO NOT SUBMERGE IN WATER.**

# 32 CARE AND CLEANING

## Care & Cleaning Tips

Keeping the refrigerator clean maintains its appearance and prevents odor build-up. Wipe up any spills immediately and clean the freezer and fresh food compartments at least twice a year.



### NOTE

Do not use abrasive cleaners such as window sprays, scouring cleansers, flammable fluids, cleaning waxes, concentrated detergents, bleaches, or cleansers containing petroleum products on plastic parts, interior doors, gaskets, or cabinet liners. Do not use scouring pads or other abrasive cleaning materials.

- Never use metallic scouring pads, brushes, abrasive cleaners, or strong alkaline solutions on any surface.
- Never use CHLORIDE or cleaners with bleach to clean stainless steel.
- Do not wash any removable parts in a dishwasher.



### NOTE

When setting temperature controls to turn off cooling, power to lights and other electrical components will continue until the power cord is unplugged from the wall outlet.

- Always unplug the electrical power cord from the wall outlet before cleaning.
- Remove adhesive labels by hand. Do not use razor blades or other sharp instruments which can scratch the appliance surface.
- Do not remove the serial plate. Removal of the serial plate voids the warranty.
- Before moving refrigerator, raise the anti-tip brackets so the rollers will work correctly. This will prevent the floor from being damaged.

Refer to the guide on the next page for details on caring and cleaning specific areas of refrigerator.



### CAUTION

- Pull the refrigerator straight out to move it. Shifting it from side to side may damage flooring. Be careful not to move the refrigerator beyond the plumbing connections.
- Damp objects stick to cold metal surfaces. Do not touch refrigerated surfaces with wet or damp hands.



### IMPORTANT

When storing or moving refrigerator in freezing temperatures, be sure to completely drain the water supply system. Failure to do so could result in water leaks when the refrigerator is put back into service. Contact a service representative to perform this operation.

## Vacation and moving tips

### Occasion Tips

#### Short Vacations

- Leave refrigerator operating during vacations of 3 weeks or less.
- Use all perishable items from refrigerator compartment.
- Turn automatic ice maker off and empty ice bucket, even if only away a few days.

#### Long Vacations

- Remove all food and ice if leaving for one month or more.
- Turn the cooling system off (see **CONTROLS AND SETTINGS** for the location of **On/Off**) and disconnect the power cord.
- Turn the water supply valve to close.
- Clean interior thoroughly.
- Leave both doors open to prevent odors and mold build-up. Block doors open if necessary.

#### Moving

- Unplug the unit.
- Remove all food and ice.
- If using a handcart, load from the side.
- Adjust rollers all the way up to protect them during sliding or moving.
- Pad cabinet to avoid scratching surface.



Care & Cleaning Tips		
Part	What To Use	Tips and Precautions
<b>Interior &amp; Door Liners</b>	<ul style="list-style-type: none"> <li>• Soap and water</li> <li>• Baking soda and water</li> </ul>	Use two tablespoons of baking soda in one quart of warm water. <b>Be sure to wring excess water out of sponge or cloth before cleaning around controls, light bulb or any electrical part.</b>
<b>Door Gaskets</b>	<ul style="list-style-type: none"> <li>• Soap and water</li> </ul>	Wipe gaskets with a clean soft cloth.
<b>Drawers &amp; Bins</b>	<ul style="list-style-type: none"> <li>• Soap and water</li> </ul>	Use a soft cloth to clean drawer runners and tracks.
<b>Glass Shelves</b>	<ul style="list-style-type: none"> <li>• Soap and water</li> <li>• Glass cleaner</li> <li>• Mild liquid sprays</li> </ul>	Allow glass to warm to room temperature before immersing in warm water.
<b>Exterior &amp; Handles</b>	<ul style="list-style-type: none"> <li>• Soap and water</li> <li>• Non Abrasive Glass Cleaner</li> </ul>	Do not use commercial household cleaners containing ammonia, bleach or alcohol to clean handles. Use a soft cloth to clean smooth handles or exterior. <b>DO NOT use a dry cloth to clean smooth doors.</b>
<b>Exterior &amp; Handles (Stainless Steel Models Only)</b>	<ul style="list-style-type: none"> <li>• Soap and water</li> <li>• Stainless Steel Cleaners such as <b>Frigidaire ReadyClean™ Stainless Steel Cleaner.</b></li> </ul>	<p><b>Never use CHLORIDE or cleaners with bleach to clean stainless steel.</b></p> <p>Clean stainless steel front and handles with non-abrasive soapy water and a dish-cloth. Rinse with clean water and a soft cloth. Use a non-abrasive stainless steel cleaner. These cleaners can be purchased at most home improvement or major department stores. Always follow manufacturer's instructions. Do not use household cleaners containing ammonia or bleach.</p> <p><b>NOTE: Always clean, wipe and dry with the grain to prevent scratching.</b> Wash the rest of the cabinet with warm water and mild liquid detergent. Rinse well, and wipe dry with a clean soft cloth. Stainless steel cleaning supplies can be purchased from <a href="http://Frigidaire.com">Frigidaire.com</a></p>

# 34 TROUBLESHOOTING

---

Let us help you troubleshoot your concern! This section will help you with common issues. If you need us, visit our website, chat with an agent, or call us. We may be able to help you avoid a service visit. If you do need service, we can get that started for you!

**1-800-374-4432 (United States)**  
**Frigidaire.com**

**1-800-265-8352 (Canada)**  
**Frigidaire.ca**

<b>Concern</b>	<b>Potential Cause</b>	<b>Common Solution</b>
<b>Automatic Ice Maker</b>		
Ice maker is not making any ice.	<ul style="list-style-type: none"><li>• Ice maker is turned off.</li><li>• Refrigerator is not connected to water line or water valve is not open.</li><li>• The water supply line is kinked.</li><li>• The water filter is not seated properly.</li><li>• The water filter may be clogged with foreign material.</li></ul>	<ul style="list-style-type: none"><li>• Press and hold the ice maker button on the appliance control display for 3 seconds. The LED indicator will illuminate to indicate that the ice maker is ON.</li><li>• Connect the unit to the household water supply and ensure the water valve is open.</li><li>• Ensure that the supply line does not kink when the refrigerator is pushed into place against the wall.</li><li>• Remove and re-install the water filter. Be sure to seat it fully into the locked position.</li><li>• If water dispenses slowly or not at all, or if the filter is six months old or older, it should be replaced.</li></ul>

Concern	Potential Cause	Common Solution
<b>Automatic Ice Maker (continued)</b>		
Ice maker is not making enough ice.	<ul style="list-style-type: none"> <li>• Ice maker is producing less ice than expected.</li>   <li>• The water filter may be clogged with foreign material.</li>   <li>• The water supply line is kinked.</li>   <li>• Saddle valve on cold water pipe is clogged or restricted by foreign material.</li>   <li>• Water pressure is extremely low. Cut-off and cut-on pressures are too low (well systems only).</li>   <li>• Reverse osmosis system is in regenerative phase.</li>   <li>• Heavy traffic, opening or closing of the doors excessively.</li> </ul>	<ul style="list-style-type: none"> <li>• Both counter depth and standard depth model ice makers should produce 3.2 to 3.7 pounds of ice per 24 hours depending on usage conditions. The counter depth ice bin will hold about 4 pounds of ice, and the standard depth ice bin will hold about 5 pounds of ice.</li>   <li>• If water dispenses slower than normal, or if the filter is six months old or older, it should be replaced.</li>   <li>• Ensure that the supply line does not kink when the refrigerator is pushed into place against the wall.</li>   <li>• Turn off household water line valve. Remove valve. Ensure that valve is not a self-piercing saddle valve. Clean valve. Replace valve if necessary.</li>   <li>• Have someone turn up the cut-off and cut-on pressure on the water pump system (well systems only).</li>   <li>• It is normal for a reverse osmosis system to be below 20 psi during the regenerative phase.</li> </ul>
Ice cubes are freezing together.	<ul style="list-style-type: none"> <li>• Ice cubes are not being used frequently enough or interruption of power for prolonged time.</li>   <li>• Ice cubes are hollow (shells of ice with water inside). The hollow cubes break open in the bin and leak their water onto existing ice, which causes it to freeze together.</li> </ul>	<ul style="list-style-type: none"> <li>• Remove ice container and discard ice. The ice maker will produce fresh supply. Ice should be used at least twice weekly to keep the cubes separated.</li>   <li>• This generally occurs when the ice maker does not get enough water. This is usually the result of a clogged water filter or restricted water supply. Replace the water filter and if the condition still occurs, check to see if the water valve is not turned on all the way or if there is a kinked water supply line.</li> </ul>

# 36 TROUBLESHOOTING

Concern	Potential Cause	Common Solution
<b>Dispenser</b>		
Dispenser will not dispense ice.	<ul style="list-style-type: none"> <li>• There is no ice in the bin to be dispensed.</li> <li>• The refrigerator doors are not completely closed.</li> <li>• Dispenser paddle has been pressed too long and the dispenser motor has overheated.</li> </ul>	<ul style="list-style-type: none"> <li>• See the <b>Ice maker is not making any ice</b> section.</li> <li>• Be sure the refrigerator doors are completely closed.</li> <li>• The motor overload protector will reset in about three minutes and then ice can be dispensed.</li> </ul>
Ice dispenser is jammed.	<ul style="list-style-type: none"> <li>• Ice has melted and frozen around auger due to infrequent use, temperature fluctuations, and/or power outages.</li> <li>• Ice cubes are jammed between ice maker and back of ice container.</li> </ul>	<ul style="list-style-type: none"> <li>• Remove ice container, thaw, and empty the contents. Clean container, wipe dry, and replace in proper position. When new ice is made, dispenser should operate.</li> <li>• Remove ice cubes that are jamming the dispenser.</li> </ul>
Dispenser will not dispense water.	<ul style="list-style-type: none"> <li>• Water filter not seated properly.</li> <li>• Water filter is clogged.</li> <li>• Household water line valve is not open.</li> </ul>	<ul style="list-style-type: none"> <li>• Remove and reinstall the water filter. For <b>PurePour Connect</b>, be sure to push the filter in all the way until it clicks into place and is secured inside of the water filter housing.</li> <li>• Replace filter cartridge. Be sure to push filter all the way in until it clicks into place and is secured inside of the water filter housing.</li> <li>• Open household water line valve. See <b>CONCERN</b> column <b>AUTOMATIC ICE MAKER</b>.</li> </ul>
Water not cold enough.	<ul style="list-style-type: none"> <li>• As warmer tap water goes through the filter and enters the water supply system, the chilled water is pushed through to the dispenser. Once the chilled water is used up, it will take several hours to bring the freshly replaced water to a cooler temperature.</li> </ul>	<ul style="list-style-type: none"> <li>• Add ice to cup or container before dispensing water.</li> </ul> <p>Note: Only first 26 ounces are chilled.</p>
Water has an odd taste and/or odor.	<ul style="list-style-type: none"> <li>• Water has not been dispensed for an extended period of time.</li> <li>• Unit not properly connected to cold water line.</li> </ul>	<ul style="list-style-type: none"> <li>• Draw and discard 10-12 glasses of water to freshen the supply.</li> <li>• Connect unit to cold water line that supplies water to the kitchen faucet.</li> </ul>

Concern	Potential Cause	Common Solution
<b>Opening/Closing Of Doors/Drawers</b>		
Door(s) will not close.	<ul style="list-style-type: none"> <li>• Door was closed too hard, causing other door to open slightly.</li> <li>• Refrigerator is not level. It rocks on the floor when moved slightly.</li> <li>• Refrigerator is touching a wall or cabinet.</li> <li>• Food/packaging is obstructing the door from closing.</li> <li>• Flipper mullion on left fresh food door is not in the correct position.</li> </ul>	<ul style="list-style-type: none"> <li>• Close both doors gently.</li> <li>• Ensure floor is level and solid, and can adequately support the refrigerator. Contact a carpenter to correct a sagging or sloping floor.</li> <li>• Ensure floor is level and solid, and can adequately support the refrigerator. Contact a carpenter to correct a sagging or sloping floor.</li> <li>• Make sure there is no food/packaging blocking the doorway.</li> <li>• Ensure the flipper mullion is in the correct position to allow the door to close. (See <b>Flipper Mullion</b> in <b>INSTALLATION.</b>)</li> </ul>
Drawers are difficult to move.	<ul style="list-style-type: none"> <li>• Food is touching shelf on top of drawer.</li> <li>• Track that drawers slide on is dirty.</li> </ul>	<ul style="list-style-type: none"> <li>• Remove top layer of items in drawer.</li> <li>• Ensure drawer is properly installed on track.</li> <li>• Clean drawer, rollers, and track. See <b>CARE AND CLEANING.</b></li> </ul>
<b>Running of Refrigerator</b>		
Compressor does not run.	<ul style="list-style-type: none"> <li>• Refrigerator is in defrost cycle.</li> <li>• Plug at electrical outlet is disconnected.</li> <li>• House fuse blown or tripped circuit breaker.</li> <li>• Power outage.</li> </ul>	<ul style="list-style-type: none"> <li>• This is normal for a fully automatic defrost refrigerator. The defrost cycle occurs periodically, lasting about 30 minutes.</li> <li>• Ensure plug is tightly pushed into outlet.</li> <li>• Check/replace fuse with a 15-amp time-delay fuse. Reset circuit breaker.</li> <li>• Check house lights. Call local electric company.</li> </ul>
Refrigerator seems to run too much or too long.	<ul style="list-style-type: none"> <li>• The variable speed compressor is designed to run 100% of the time except during the defrost cycle. At times it will run faster, such as after a defrost cycle.</li> </ul>	<ul style="list-style-type: none"> <li>• It is normal for the compressor to run continuously except during defrost mode.</li> </ul>

# 38 TROUBLESHOOTING

Concern	Potential Cause	Common Solution
<b>Digital Temperature Setting Display</b>		
Digital temperature displays an error.	<ul style="list-style-type: none"> <li>Electronic control system has detected a performance problem.</li> </ul>	<ul style="list-style-type: none"> <li>For assistance with any errors or codes flashing in the appliance control display call 1-800-374-4432.</li> </ul>
<b>Water/Moisture/Frost Inside Refrigerator</b>		
Moisture collects on inside of refrigerator walls.	<ul style="list-style-type: none"> <li>Weather is hot and humid.</li> <li>Flipper mullion</li> </ul>	<ul style="list-style-type: none"> <li>The rate of frost buildup and internal sweating increases.</li> <li>Adjust flipper mullion. (See <b>Flipper Mullion</b> in <b>INSTALLATION</b>.)</li> </ul>
Water collects on bottom side of drawer cover.	<ul style="list-style-type: none"> <li>Vegetables contain and give off moisture.</li> </ul>	<ul style="list-style-type: none"> <li>It is not unusual to have moisture on the bottom side of the cover.</li> <li>Both crispers contain an automatic humidity control, which should adjust automatically to the varying levels of moisture inside the drawer without creating additional condensation or drying out the air inside the crisper drawer, works with various types of produce. If excess moisture is noticed, check to verify humidity membrane is not damaged and replace as necessary.</li> </ul>
Water collects in bottom of drawer.	<ul style="list-style-type: none"> <li>Washed vegetables and fruit drain while in the drawer.</li> </ul>	<ul style="list-style-type: none"> <li>Dry items before putting them in the drawer. Water collecting in bottom of drawer is normal.</li> </ul>
<b>Water/Moisture/Frost Outside Refrigerator</b>		
Moisture collects on outside of refrigerator or between doors.	<ul style="list-style-type: none"> <li>Weather is humid.</li> </ul>	<ul style="list-style-type: none"> <li>This is normal in humid weather. When humidity is lower, the moisture should disappear.</li> </ul>
<b>Food/Drinks in Fresh Food Compartment/Custom-Flex Drawer</b>		
Food is freezing.	<ul style="list-style-type: none"> <li>Temperature setting is too low.</li> <li>Temperature sensor is covered by food (right side of fresh food area).</li> <li>Food is covering the air ports.</li> </ul>	<ul style="list-style-type: none"> <li>Move the setting to a higher degree.</li> <li>Allow space for air flow to the sensor.</li> <li>Allow space between the air ports and the food.</li> </ul>

Your appliance is covered by a one year limited warranty. For one year from your original date of purchase, Electrolux will pay all costs for repairing or replacing any parts of this appliance that prove to be defective in materials or workmanship when such appliance is installed, used and maintained in accordance with the provided instructions.

#### Exclusions

This warranty does not cover the following:

1. Products with original serial numbers that have been removed, altered or cannot be readily determined.
2. Product that has been transferred from its original owner to another party or removed outside the USA or Canada.
3. Rust on the interior or exterior of the unit.
4. Products purchased "as-is" are not covered by this warranty.
5. Food loss due to any refrigerator or freezer failures.
6. Products used in a commercial setting.
7. Service calls which do not involve malfunction or defects in materials or workmanship, or for appliances not in ordinary household use or used other than in accordance with the provided instructions.
8. Service calls to correct the installation of your appliance or to instruct you how to use your appliance.
9. Expenses for making the appliance accessible for servicing, such as removal of trim, cupboards, shelves, etc., which are not a part of the appliance when it is shipped from the factory.
10. Service calls to repair or replace appliance light bulbs, air filters, water filters, other consumables, or knobs, handles, or other cosmetic parts.
11. Surcharges including, but not limited to, any after hour, weekend, or holiday service calls, tolls, ferry trip charges, or mileage expense for service calls to remote areas, including the state of Alaska.
12. Damages to the finish of appliance or home incurred during installation, including but not limited to floors, cabinets, walls, etc.
13. Damages caused by: services performed by unauthorized service companies; use of parts other than genuine Electrolux parts or parts obtained from persons other than authorized service companies; or external causes such as abuse, misuse, inadequate power supply, accidents, fires, or acts of God.

#### DISCLAIMER OF IMPLIED WARRANTIES; LIMITATION OF REMEDIES

CUSTOMER'S SOLE AND EXCLUSIVE REMEDY UNDER THIS LIMITED WARRANTY SHALL BE PRODUCT REPAIR OR REPLACEMENT AS PROVIDED HEREIN. CLAIMS BASED ON IMPLIED WARRANTIES, INCLUDING WARRANTIES OF MERCHANTABILITY OR FITNESS FOR A PARTICULAR PURPOSE, ARE LIMITED TO ONE YEAR OR THE SHORTEST PERIOD ALLOWED BY LAW, BUT NOT LESS THAN ONE YEAR. ELECTROLUX SHALL NOT BE LIABLE FOR CONSEQUENTIAL OR INCIDENTAL DAMAGES SUCH AS PROPERTY DAMAGE AND INCIDENTAL EXPENSES RESULTING FROM ANY BREACH OF THIS WRITTEN LIMITED WARRANTY OR ANY IMPLIED WARRANTY. SOME STATES AND PROVINCES DO NOT ALLOW THE EXCLUSION OR LIMITATION OF INCIDENTAL OR CONSEQUENTIAL DAMAGES, OR LIMITATIONS ON THE DURATION OF IMPLIED WARRANTIES, SO THESE LIMITATIONS OR EXCLUSIONS MAY NOT APPLY TO YOU. THIS WRITTEN WARRANTY GIVES YOU SPECIFIC LEGAL RIGHTS. YOU MAY ALSO HAVE OTHER RIGHTS THAT VARY FROM STATE TO STATE.

#### If You Need Service

Keep your receipt, delivery slip, or some other appropriate payment record to establish the warranty period should service be required. If service is performed, it is in your best interest to obtain and keep all receipts. Service under this warranty must be obtained by contacting Electrolux at the addresses or phone numbers below.

This warranty only applies in the USA and Canada. In the USA, your appliance is warranted by Electrolux Major Appliances North America, a division of Electrolux Home Products, Inc. In Canada, your appliance is warranted by Electrolux Canada Corp. Electrolux authorizes no person to change or add to any obligations under this warranty. Obligations for service and parts under this warranty must be performed by Electrolux or an authorized service company. Product features or specifications as described or illustrated are subject to change without notice.

**USA**  
**1-800-374-4432**  
Frigidaire  
10200 David Taylor Drive  
Charlotte, NC 28262



**Canada**  
**1.800.265.8352**  
Electrolux Canada Corp.  
5855 Terry Fox Way  
Mississauga, Ontario, Canada  
L5V 3E4

# FRIGIDAIRE®

welcome **home**

Our home is your home. Visit us if you need help with any of these things:



owner support



accessories



service



registration

(See your registration card for more information.)

Frigidaire.com  
1-800-374-4432

Frigidaire.ca  
1-800-265-8352



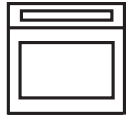

# SINGLE WALL OVEN

## *use & care*

Introduction . . . . .	2
Important Safety Instructions . . . . .	3
Cooking Recommendations . . . . .	9
Before Setting Oven Controls . . . . .	13

Setting Oven Controls . . . . .	19
Care and Cleaning . . . . .	46
Before You Call . . . . .	52
Warranty . . . . .	55

# 2

## INTRODUCTION

Welcome to our *family*

Thank you for bringing Frigidaire into your home! We see your purchase as the beginning of a long relationship together.

This manual is your resource for the use and care of your product. Please read it before using your appliance. Keep it handy for quick reference. If something doesn't seem right, the troubleshooting section will help you with common issues.

FAQs, helpful tips and videos, cleaning products, and kitchen and home accessories are available at [www.frigidaire.com](http://www.frigidaire.com).

We are here for you! Visit our website, chat with an agent, or call us if you need help. We may be able to help you avoid a service visit. If you do need service, we can get that started for you.

Let's make it official! Be sure to register your product.

Keep your product info here so it's easy to find.

Model Number: \_\_\_\_\_

Serial Number: \_\_\_\_\_

Purchase Date: \_\_\_\_\_

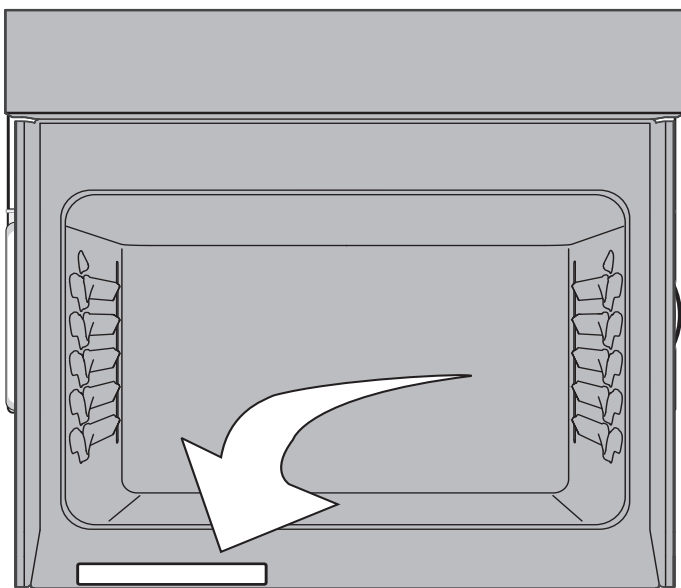

**Serial Number Location**



### Installation Checklist

- Read all the safety instructions in the front of your Use & Care Manual.
- Remove all packaging materials from your appliance before cooking.
- Confirm that the electrical power to the appliance is turned on.
- Wipe out the inside of the oven cavity with a damp cloth.
- Apply a thin layer of cooking oil to the sides of the oven racks to keep them gliding smoothly.
- Set the clock. See (page 16) for instructions.
- Before cooking, set the oven to bake at 350°F (177°C) for 30 minutes (page ref). Some noise and odors are normal on the first cooking cycle.
- Remember to complete your product registration!

Read all instructions before using this appliance.

This manual contains important safety symbols and instructions. Please pay attention to these symbols and follow all instructions given.

Do not attempt to install or operate your appliance until you have read the safety precautions in this manual. Safety items throughout this manual are labeled with a WARNING or CAUTION statement based on the risk type.

Warnings and important instructions appearing in this guide are not meant to cover all possible conditions and situations that may occur. Common sense, caution, and care must be exercised with installing, maintaining, or operating your appliance.

## DEFINITIONS

 This is the safety alert symbol. It is used to alert of potential personal injury hazards. Obey all safety messages that follow this symbol to avoid possible injury or death.

### WARNING

Indicates a potentially hazardous situation which, if not avoided, may result in death or serious injury.

### CAUTION

Indicates a potentially hazardous situation which, if not avoided, may result in minor or moderate injury.

### IMPORTANT

Indicates installation, operation or maintenance information which is important but not hazard-related.

### NOTE

Indicates a short, informal reference – something written down to assist the memory or for future reference.

### WARNING

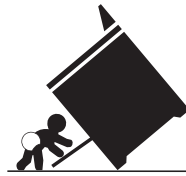

#### Tip Over Hazard

- A child or adult can tip the oven and be killed.
- Install the anti-tip device to oven and/or structure per installation instructions.
- Ensure the anti-tip device is re-engaged when the oven is moved.
- Do not operate the oven without the anti-tip device in place and engaged.
- Failure to follow these instructions can result in death or serious burns to children and adults.

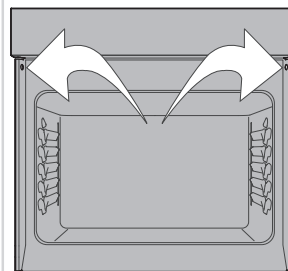

Refer to the installation instructions supplied with your appliance for proper installation.

#### Anti-tip mounting holes

Check for proper installation with a visual check that the anti-tip screws are present. Test the installation with light downward pressure on the open oven door. The oven should not tip forward.

# 4

## IMPORTANT SAFETY INSTRUCTIONS

---

### IMPORTANT INSTRUCTIONS FOR UNPACKING AND INSTALLATION

#### IMPORTANT

Read and follow the below instructions and precautions for unpacking, installing, and servicing your appliance.

Remove all tape and packaging before using the appliance. Destroy the carton and plastic bags after unpacking the appliance. Never allow children to play with packaging material. Do not remove the wiring label and other literature attached to the appliance. Do not remove model/serial number plate.

Cold temperatures can damage the electronic control. When using this appliance for the first time, or when the appliance has not been used for an extended period of time, be sure the appliance has been in temperatures above 32°F (0°C) for at least 3 hours before turning on the power to the appliance.

All materials used in construction of cabinets, enclosures, and supports surrounding the product must have a temperature rating above 194°F (90°C).

Never modify or alter the construction of the appliance by removing the leveling legs, panels, wire covers, anti-tip brackets/screws, or any other part of the appliance.

Be sure to have an appropriate foam-type fire extinguisher available, visible, and easily accessible located near the appliance.

### GROUNDING INSTRUCTIONS

#### WARNING

- Avoid fire hazard or electrical shock. Failure to follow this warning may cause serious injury, fire, or death.
- Avoid fire hazard or electrical shock. Do not use an adapter plug, use an extension cord, or remove grounding prong from the power cord. Failure to follow this warning may cause serious injury, fire, or death.

Proper Installation—Be sure your appliance is properly installed and grounded by a qualified technician. In the United States, install in accordance with the National Fuel Gas Code ANSI Z223.1/NPFA No. 54, latest edition and National Electrical Code NFPA No. 70 latest edition, and local electrical code requirements. In Canada, install in accordance with CAN/CGA B149.1 and CAN/CGA B149.2 and CSA Standard C22.1, Canadian Electrical code, Part 1-latest editions and local electrical code requirements. Install only per installation instructions provided in the literature package for this appliance.

For personal safety, this appliance must be properly grounded. For maximum safety, the power cord must be securely connected to an electrical outlet or junction box that is the correct voltage, is correctly polarized and properly grounded, and protected by a circuit breaker in accordance with local codes.

It is the personal responsibility of the consumer to have the appropriate outlet or junction box with the correct, properly grounded wall receptacle installed by a qualified electrician. It is the responsibility and obligation of the consumer to contact a qualified installer to assure that

---

the electrical installation is adequate and is in conformance with all local codes and ordinances.

See the installation instructions packaged with this appliance for complete installation and grounding instructions.

**IMPORTANT INSTRUCTIONS FOR USING THE APPLIANCE**

 **WARNING**

- Storage In or On Appliance—Flammable materials should not be stored in an oven or microwave, near surface burners or elements, or in the storage or warmer drawer (if equipped). This includes paper, plastic, and cloth items, such as cookbooks, plastic ware, and towels, as well as flammable liquids. Do not store explosives, such as aerosol cans, on or near the appliance.
- Do not leave children alone - Children should not be left alone or unattended in the area where appliance is in use. They should never be allowed to sit or stand on any part of the appliance, including the storage drawer, lower broiler drawer, warmer drawer, or lower double oven.
- Do not store items of interest to children in the cabinets above the appliance or on the backguards of ranges. Children climbing on or near the appliance to reach items could be seriously injured.
- Do not allow children to climb or play around the appliance. The weight of a child on an open oven door may cause the appliance to tip, resulting in serious burns or other injury. An open drawer when hot may cause burns.

 **WARNING**

- Stepping, leaning, or sitting on the door or drawers of this appliance can result in serious injuries and also cause damage to the appliance.
- Never cover any slots, holes or passages in the oven bottom or cover and entire rack with materials such as aluminum foil. Aluminum foil linings may also trap heat, causing a fire hazard.
- Do not use oven or warmer drawer (if equipped) for storage.
- Never use your appliance as a space heater to heat or warm the room. Doing so may result in carbon monoxide poisoning and overheating of the appliance.

 **CAUTION**

- When heating fat or grease, watch it closely. Grease may catch fire if it becomes too hot.
- Do not use water or flour on grease fires. Smother fire or flame or use dry chemical or foam-type extinguisher. Cover the fire with a pan lid or use baking soda.
- Use dry potholders. Moist or damp potholders on hot surfaces may result in burns from steam. Do not let potholders touch hot cooking areas. Do not use towels or other bulky cloths.
- Do not heat unopened food containers - Build-up of pressure may cause container to burst and result in injury.

# 6

## IMPORTANT SAFETY INSTRUCTIONS

---

### CAUTION

- Wear proper apparel - Loose-fitting or hanging garments should never be worn while using the appliance. Do not let clothing or other flammable materials contact hot surfaces.
- Do not touch surface burners or elements, areas near these burners or elements, interior surfaces of the oven, or the warmer drawer (if equipped). Surface burners and elements may be hot even though they appear cool. Areas near surface burners and elements may become hot enough to cause burns. During and after use, do not touch, or let clothing or other flammable materials touch these areas until they are cool. These areas may include the cooktop, surfaces facing the cooktop, oven vent areas, oven door, and oven window.
- Do not attempt to operate the appliance during a power failure. If the power fails, always turn off the appliance. If the appliance is not turned off and the power resumes, electric surface elements may resume operation when power is restored. Once the power resumes, reset the clock and the oven function.

### IMPORTANT INSTRUCTIONS FOR USING YOUR OVEN

Protective liners—Do not use aluminum foil, aftermarket oven liners, or any other materials or devices to line oven bottom, oven racks, or any other part of the appliance. Only use aluminum as recommended for baking, such as lining cookware or as a cover placed on food. Any other use of protective liners or aluminum foil may result in a risk of electric shock or fire or a short circuit.

Use care when opening oven door, lower oven door, or warmer drawer (some models). Stand to the side of the appliance when opening the door of a hot oven. Let hot air or steam escape before you remove or replace food in the oven.

Keep oven vent ducts unobstructed. Touching surfaces in this area when the oven is on may cause severe burns. Do not place plastic or heat-sensitive items on or near the oven vent. These items can melt or ignite.

Placement of oven racks - Always place oven racks in desired location while oven is cool. If rack must be moved while oven is hot, do not let potholder contact hot burner or element in oven. Use potholders and grasp the rack with both hands to reposition. Remove all cookware and utensils before moving the rack.

Do not use a broiler pan without its insert. Broiler pans and inserts allow dripping fat to drain away from the high heat of the broiler. Do not cover the broiler insert with aluminum foil; exposed fat and grease could ignite.

Do not cook food on the oven bottom. Always cook in proper cookware and always use the oven racks.

---

**IMPORTANT INSTRUCTIONS FOR CLEANING YOUR APPLIANCE** **CAUTION**

Before manually cleaning any part of the appliance, be sure all controls are turned off and the appliance is cool. Cleaning a hot appliance can cause burns.

Clean the appliance regularly to keep all parts free of grease that could catch fire. Do not allow grease to accumulate. Greasy deposits in the fan could catch fire.

Always follow the manufacturer's recommended directions for use of kitchen cleaners and aerosols. Be aware that excess residue from cleaners and aerosols may ignite causing damage and injury.

Clean ventilating hoods frequently - Grease should not be allowed to accumulate on hood or filter. Follow the manufacturer's instructions for cleaning vent hoods.

**IMPORTANT INSTRUCTIONS FOR SELF CLEANING OVENS** **CAUTION**

Before using self clean, remove the broiler pan, any food, utensils, and cookware from the oven, storage drawer or warming drawer (if equipped). Remove oven racks unless otherwise instructed.

Do not clean the oven door gasket. The door gasket is essential for a good seal. Care should be taken not to rub, damage, or move the gasket.

Do not use oven cleaners. No commercial oven cleaner or oven liner protective coating of any kind should be used in or around any part of the appliance.

Use the self clean cycle to clean only the parts listed in this manual.

Some birds are extremely sensitive to the fumes given off during the self clean cycle of any oven. Move birds to another well-ventilated room.

---

# 8

## IMPORTANT SAFETY INSTRUCTIONS

---

### IMPORTANT INSTRUCTIONS FOR SERVICE AND MAINTENANCE

Do not repair or replace any part of the appliance unless specifically recommended in the manuals. All other servicing should be done only by a qualified technician. This reduces the risk of personal injury and damage to the appliance.

Always contact your dealer, distributor, service agent, or manufacturer about problems or conditions you do not understand.

Ask your dealer to recommend a qualified technician and an authorized repair service. Know how to disconnect the power to the appliance at the circuit breaker or fuse box in case of an emergency.

Remove the oven door from any unused oven if it is to be stored or discarded.

Do not touch a hot oven light bulb with a damp cloth. Doing so could cause the bulb to break. Handle halogen lights (if equipped) with paper towels or soft gloves. Disconnect the appliance or shut off the power to the appliance before removing and replacing the bulb.



### WARNING

California Residents: for cancer and reproductive harm information, visit [www.P65Warnings.ca.gov](http://www.P65Warnings.ca.gov)



**Special Features**



Use the special features of your Frigidaire oven to get the best baking and roasting results.

Goal	Feature
<ul style="list-style-type: none"> <li>• Steaks perfectly cooked to your preference</li> <li>• Juicy pork and poultry</li> <li>• Eggs just as hard or soft as you like them</li> <li>• Vegetables that remain firm and crisp</li> </ul>	<p><b>Air Sous Vide</b></p> <p>The precisely-controlled heat and airflow give you sous vide results without the water bath, preserving natural flavors and locking in moisture.</p>
<ul style="list-style-type: none"> <li>• Breads and pastries that rise higher with a crispy, golden crust and a light and flaky interior</li> </ul>	<p><b>Steam Bake</b></p> <p>Steam baking slows the formation of the crust, allowing your dough to grow longer before the crust forms.</p>
<ul style="list-style-type: none"> <li>• Moist and tender meats with a golden, crispy skin on the outside.</li> </ul>	<p><b>Steam Roast</b></p> <p>The humidity of steam roasting prevents meats from drying out during the cooking process.</p>
<ul style="list-style-type: none"> <li>• Golden, crispy chicken wings</li> <li>• Crunchy vegetable chips</li> <li>• Juicy chicken parmesan</li> <li>• Perfectly crisp tempura shrimp, samosas, and more</li> </ul>	<p><b>Air Fry</b></p> <p>The hot air convection makes crisp, golden fried foods without the splatter. For even heating on all sides and large capacity, use the Air Fry Tray (included).</p>
<ul style="list-style-type: none"> <li>• Airy breads and balanced pizza dough</li> </ul>	<p><b>Bread Proof</b></p> <p>Bread proofing keeps your oven at the best temperature and humidity for yeast to cause your dough to rise.</p>
<ul style="list-style-type: none"> <li>• Prepare convenience foods without delay</li> </ul>	<p><b>No Preheat</b></p> <p>Get your culinary delights on the table faster</p>
<ul style="list-style-type: none"> <li>• Healthy, flavorful fruit snacks</li> <li>• Lean meat jerky</li> <li>• Dried herbs</li> </ul>	<p><b>Dehydrate</b></p> <p>The dehydrate feature keeps the oven on low humidity and low heat to dry foods without cooking them.</p>
<ul style="list-style-type: none"> <li>• Perfectly browned baked goods</li> <li>• Evenly cooked roasts and braises</li> </ul>	<p><b>Convection Bake</b></p> <p>Even your most challenging recipes turn out delicious with the precisely-controlled heat and air circulation of Advanced Convection</p>
<ul style="list-style-type: none"> <li>• Roast turkey that's crispy on the outside and juicy on the inside.</li> </ul>	<p><b>Turkey Option</b></p> <p>Precisely times your convection roast for turkey that is perfectly done.</p>
<ul style="list-style-type: none"> <li>• Prevent build-up of burred, spilled food in the bottom of the oven</li> </ul>	<p><b>One Hour Steam Clean</b></p> <p>Keep your oven looking its best with the one hour Steam Clean cycle that's chemical- and odor-free</p>

# 10 COOKING RECOMMENDATIONS

## Bakeware

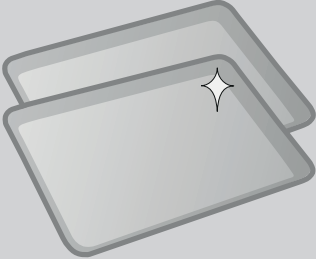
The material of bakeware affects how evenly and quickly it transfers heat from the pan to the food.

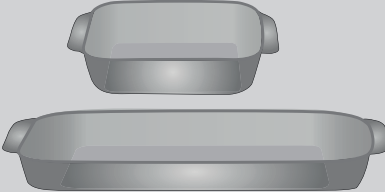
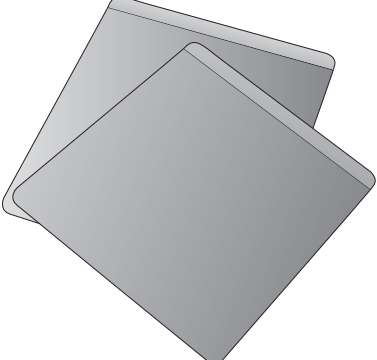
Material	Attributes	Recommendation
<p>Shiny metal bakeware</p> 	<p>Shiny, aluminum, and non-coated bakeware is the best for even heating. It is suitable for all baked goods.</p>	<p>Recommended cooking temperatures and times are based on shiny metal bakeware.</p>
<p>Dark metal bakeware</p> 	<p>Dark bakeware cooks hotter than shiny bakeware.</p>	<p>Reduce the cooking temperature by 25°F (13-14°C) when using dark bakeware.</p>
<p>Glass bakeware</p> 	<p>Glass bakeware cooks hotter than shiny bakeware.</p> <p>Glass is convenient, as the same piece of bakeware can be used for cooking, serving, and storing food.</p>	<p>Reduce the cooking temperature by 25°F (13-14°C) when using glass bakeware.</p>
<p>Insulated bakeware</p> 	<p>Insulated bakeware cooks cooler than shiny bakeware.</p> <p>Insulated bakeware is designed for baking in gas ovens.</p>	<p>When using insulated bakeware, the recipe baking time may be longer than usual.</p>

**Cooking Conditions**

Conditions in your kitchen can affect the performance of your appliance when cooking food.

<b>Condition</b>	<b>Attributes</b>	<b>Recommendation</b>
Aging cookware	As pans age and become discolored, cooking times may need to be reduced slightly.	If food is too dark or overcooked, use the minimum cook time in the recipe or packaging.  If food is too light or undercooked, use the middle to maximum cook time in the recipe or packaging.
High altitude	Air is drier and air pressure is lower.  Water boils at a lower temperature, and liquids evaporate faster.  Foods may take longer to bake.  Doughs may rise faster.	Adjust cooking temperature, cooking time, or recipes as needed.  Increase amount of liquid in baking recipes.  Increase cook time on cooktop. Cover dishes to reduce evaporation.  Increase bake time or oven temperature.  Reduce amount of baking soda or baking powder in recipe. Reduce rising time or punch down dough and allow it to rise twice.

**Cooking Results**

Small adjustments may help you achieve the best results.

<b>Result</b>	<b>Recommendation</b>
Food too light	Use the middle to maximum cook time recommended on packaging or recipe.
Food too dark	Use the minimum cook time recommended on packaging or recipe.

**Cooking Tips**

Use these additional tips to get the best results from your appliance.

<b>Situation</b>	<b>Recommendation</b>
<b>Baking</b>	
Rack placement	Follow the instructions in particular oven mode starting in “Setting Oven Controls” on page 20.
Preheat	Fully preheat the oven before baking items like cookies, cakes, biscuits and breads. Insert food immediately after the beep.
Checking food	Use the window and oven light when checking food. Opening the door may reduce baking performance.
Bake or Convection Bake	Convection bake is the best function to use for baking on multiple racks. For best performance, see “Convection Bake” on page 24
Steam Bake	For directions, tips, and benefits of Steam Bake see “Steam Bake” on page 36.
Food placement	Allow at least 2 inches (5 cm) of space between bakeware for proper air circulation.

# 12 COOKING RECOMMENDATIONS

Material	Recommendation
<b>Broiling / Roasting</b>	
Broiling pan	For best results when broiling, use a broil pan with an insert designed to drain the fat from the food, help avoid spatter, and reduce smoking. The broiler pan will catch grease spills, and the insert helps prevent grease splatters.
<b>Convection Cooking</b>	
Convection attributes	Convection cooking uses a fan to circulate hot air around the oven and food. It browns food more evenly and reduces hot spots in the oven. Convection saves time when using multiple racks or cooking several food items at once.
Convection bake	Reduce cooking temperature by 25° F (13-14° C) from the recipe unless the recipe is written for convection baking. Preheat the oven for best results.
Convection roast	<p>Convection roast is best for meats and does not require preheating for most meats and poultry.</p> <p>Reducing the cooking temperature for convection roast is not recommended. Carefully follow your recipe's temperature and time recommendations, adjusting the cooking time if the recipe does not specify convection roasting time.</p> <p>Since convection roast cooks faster, cook time may be reduced by 25% to 40% depending on food type. You can reduce cook times by 25% from the recommended time of your recipe, and check the food at this time. If needed, continue cooking until the desired doneness is obtained.</p> <p>Use the meat probe included with your appliance. Meat probes are also available from most grocery and home goods stores.</p> <p>Arrange oven racks so large cuts of meat and poultry are on the lowest rack of the oven.</p> <p>Do not cover foods when dry roasting - covering will prevent the meat from browning properly.</p> <p>When cooking meats, use the broiler pan and insert or a roasting rack. The broiler pan will catch grease spills and the insert helps prevent grease splatters.</p>

## ➔ IMPORTANT

Your Frigidaire wall oven has many features that allow you to customize the way your oven works.

Take time to read this section for important safety information and to become familiar with the many menu option settings starting on page 15.

### Oven Vent Location

The oven is vented as shown below. When the oven is on, warm air is released through the vent. This venting is necessary for proper air circulation in the oven and good baking results. Do not block oven vent. Never close off the openings with aluminum foil or any other material. Steam or moisture may appear near the oven vent. This is normal.

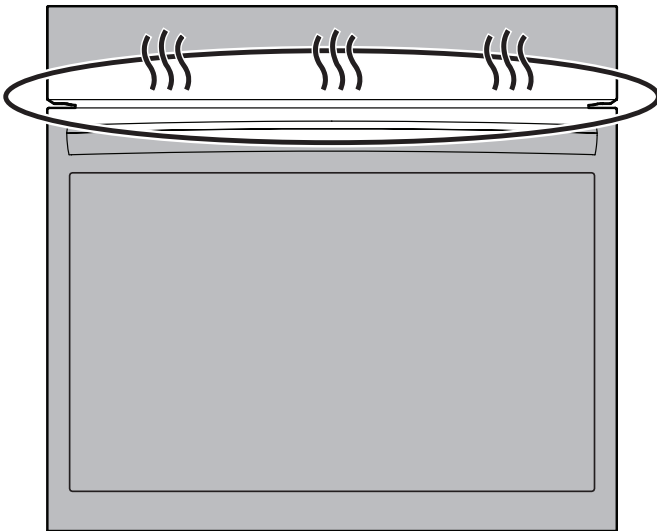

Figure 1: Oven vent

## ! WARNING

**Protective Liners** — Do not use aluminum foil or any other material or liners to line the oven bottom, walls, racks or any other part of the range. Doing so will alter the heat distribution, produce poor baking results, and possibly cause permanent damage to the oven interior. Improper installation of these liners may result in risk of electric shock or fire. During self clean, temperatures in the oven will be hot enough to melt foil.

## ! CAUTION

Always use pot holders or oven mitts when using the oven. When cooking, the oven interior, oven exterior, oven racks, and cooktop will become very hot which can cause burns.

Remove all oven racks before starting a self clean cycle. If oven racks are left inside the oven during a cleaning cycle, the slide ability of the oven racks may be damaged and all of the oven racks will lose their shiny finish.

To prevent possible damage to the oven, do not attempt to close the oven door until all the oven racks are fully positioned back inside the oven cavity.

### Types of Oven Rack

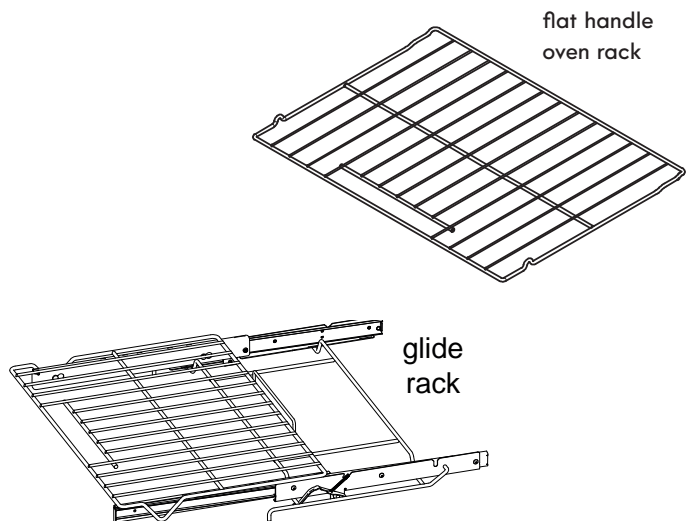

Figure 2: Oven rack types

- **Flat oven racks** may be used for most cooking needs and may be placed in most oven rack positions.
- The fully extendable **glide rack** makes food preparation easier. This oven rack has glide tracks that allow the rack to be pulled away from the oven without rubbing the sides of the oven wall. See glide rack instructions on next page.

# 14 BEFORE SETTING OVEN CONTROLS

## WARNING

Do not line the oven walls, racks, bottom or any other parts of the range with aluminum foil. Doing so will alter heat distribution, produce poor baking results and may cause permanent damage to the oven interior. During self-clean temperatures the oven will be hot enough to melt foil.

## Removing and Replacing the Glide Racks

The fully extendable Glide rack makes food preparation easier. This oven rack has glide tracks that allow the rack to be pulled away from the oven without rubbing the sides of the oven wall.

**To remove** - Make sure the baking rack is in the closed position. Using one hand, reach through handle opening and grasp both the upper and lower bars of the glide rack.

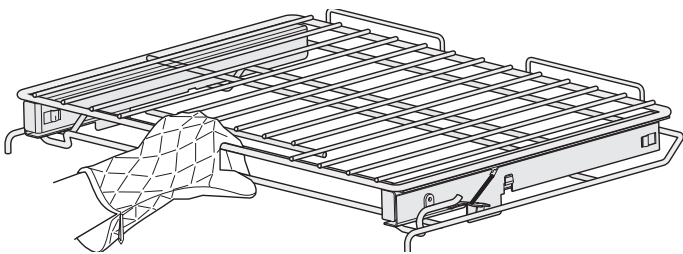

While holding both sections, pull the glide rack out of the oven until the stop position is reached.

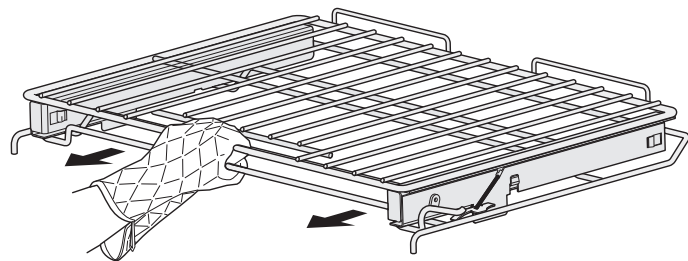

Using both hands, lift up the front of the rack slightly and continue to pull the rack away from the oven. Be sure to grasp both upper and lower rack portions together when removing or handling the glide rack.

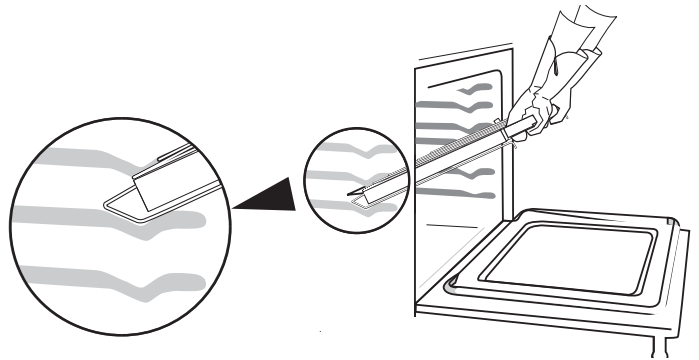

The rack portions move independently and are difficult to handle unless held together.

**To replace** - Make sure the baking rack is in the closed position. Grasp both upper and lower portions of glide rack. Lift and hold the rack level between the oven cavity walls. Tilt the front of the rack upward slightly and slide the rack completely into position.

To prevent possible damage to the oven, do not attempt to close the oven door until all the oven racks are fully positioned back inside the oven cavity.

## IMPORTANT

Remove all oven racks and clean according to instructions provided in the Care & Cleaning section of this manual. Never pick up hot oven racks or parts.

## Using Menu Options to Customize Your Cooking Experience

When you first install your appliance, the screen will prompt you to set your preferences. You can always change them later using the menu ≡ .

1. Touch the Menu Options bars and scroll to find the desired option.
2. Select option and set your preference.
3. Save and go back or **Save & Close**.

You can press the **X** to close without saving changes.

## Clock

When the appliance is first plugged in or when the power supply to the appliance has been interrupted, the display will show 12:00. It is recommended to always set the clock for the correct time of day before using the appliance.

1. Touch **Menu Options** bars and scroll to **Clock**. You will see options to turn off the clock display when the oven is off, to change from 12-hour to 24-hour time, and to set the clock.
2. Touch **Set Clock** and set time using graph.
3. Set AM or PM
4. **Save & Close**

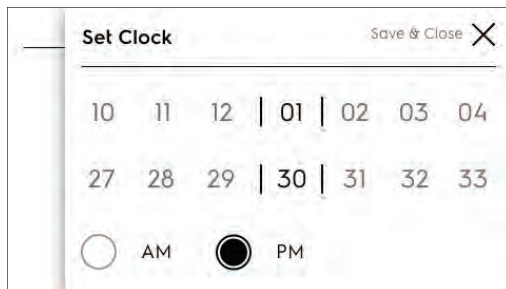

## Energy Saving Mode

The oven control has a factory preset built-in 12-Hour Energy Saving feature that will turn off the oven if the oven is left on for more than 12 hours. The control may be programmed to override this feature to bake continuously.

1. Scroll to **Energy Saving Mode** and touch.
2. Follow the information to override the Energy Saving feature if necessary.
3. **Save & Close**.

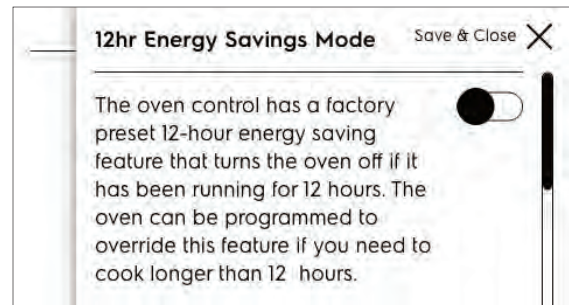

## General Settings

1. Scroll to **General Settings** and touch.
2. Different options will appear.
3. Select an option to see how it is set and change if desired.

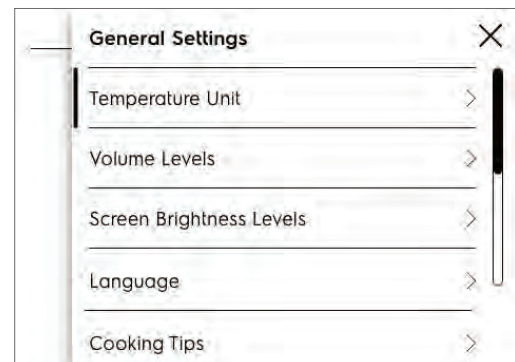

## Temperature Display

The electronic oven control is set to display °F when shipped from the factory. The display may be changed to show either °F or °C oven temperatures.

Temperature Display >  Fahrenheit  
 Celcius

1. Select **Fahrenheit** or **Celcius**.
2. **Save & Close**

# 16 BEFORE SETTING OVEN CONTROLS

## Volume

Volume allows the oven control to operate with strong tones, quiet tones, or no tones. Use the slider to set the volume.

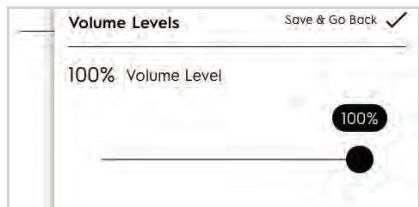

## Screen Brightness

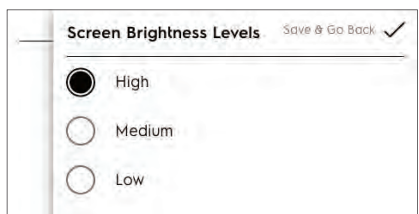

1. Choose brightness and Save & Close.

## Language



1. Select desired language.
2. **Save & Close.**

## Favorites

Scroll to Favorites and touch.

- **Quick Start Options** > Oven 350°F (can change the default when Quick Start is selected)
  1. Change temperature if desired.
  2. **Save.**
- **Temperature Options** > Adjust Custom Preheat default.
  1. 325°F / 163°C
  2. 375°F / 191°C
  3. 400°F / 204°C

### ➔ NOTE

These temperature options are also available in Custom Preheat menu on the main screen

## Cooking Tips

You can switch whether cooking tips are displayed or not by choosing On or Off.

## Oven Temperature Calibration

Your appliance has been factory calibrated and tested to ensure an accurate baking temperature. For the first few uses, follow your recipe times and temperature recommendations carefully. If you think the oven is cooking too hot or too cool for your recipe times, you can adjust the control so the oven cooks hotter or cooler than the temperature displayed.

**Important:** Do not use oven thermometers such as those found in grocery stores to check the temperature settings inside your oven. These oven thermometers may vary as much as 20 to 40 degrees from actual temperatures.

1. Scroll to **Oven Temperature Calibration** and touch.
2. Option to adjust is shown.
3. Use slide to increase or decrease default oven temperature.
4. Save and go back or **Save & Close.**

The oven temperature may be increased as much as +35°F (+19°C) or decreased -35°F (-19°C) from the factory calibrated settings.

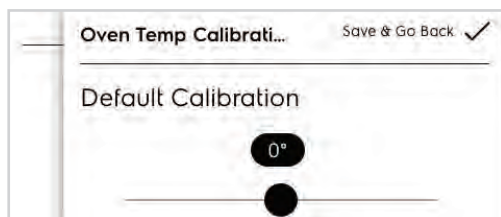



## Sabbath Mode

1. Scroll to **Sabbath Mode**.
2. Read and follow all instructions to set and when finished cancel. See “Setting the Sabbath Feature for the Jewish Sabbath and Holidays (some models)” on page 47 for complete details on how Sabbath mode works with your oven controls.

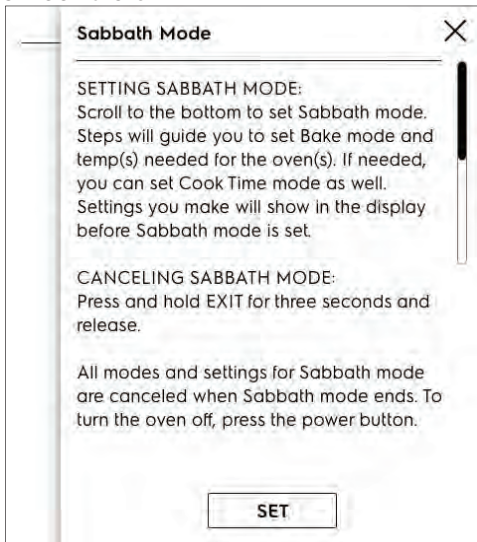

## Factory Reset

1. **Scroll to Factory Reset and touch**
2. **Follow screen prompts**

Note: Your appliance was set with predetermined (default) oven control settings. Over time, users may have made changes to these settings. The following options may have been modified since the appliance was new:

- 12 or 24 hr display mode
- Screen Brightness
- Language
- Favorites
- Show Clock
- All Food Probe settings
- Continuous bake or 12 hour energy savings mode
- Silent or audible control
- Oven temperature display (Fahrenheit or Celsius)
- Oven temperature adjustments (UPO)

If Reset is touched all the settings will return to default.

3. **Are you sure?**
4. **Reset.**
5. **OKAY**

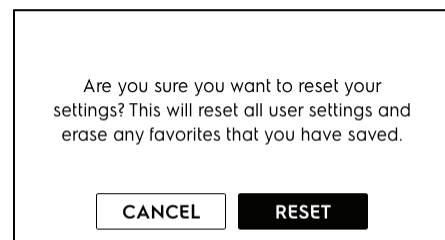

# 18 BEFORE SETTING OVEN CONTROLS

## Food Probe

Food probe options can be found in the Settings menu and the Oven Modes menu. Select Food Probe from the Settings menu to select whether the oven turns off or stays on when the specified temperature is reached during cooking.

1. Scroll to **Food Probe** and touch.
2. Follow instructions on the display.

### NOTE

For setting the oven to use the food probe, see “Cooking with Food Probe” on page 45.

## Lock Screen

As a safety measure the oven doors and controls can be locked. Follow screen directions to lock and unlock.

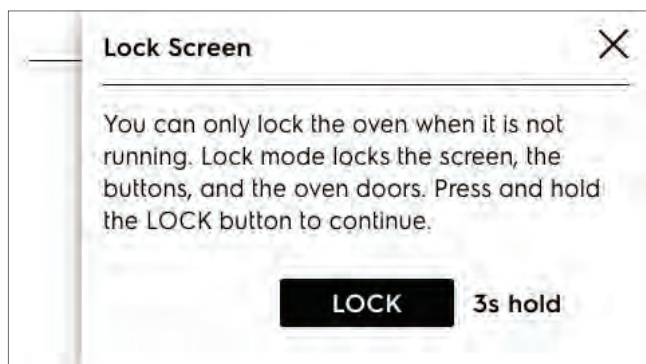

From the Settings Menu, Select **Lock Screen**, then touch and hold **LOCK** for 3 seconds.

When the doors and controls are locked the screen will show the time of day, a note that the oven is locked, and an **UNLOCK** key. Once the controls and door are locked, there is no access to any cooking functions. This ensures that the oven will remain locked and safe.

To unlock the oven door, press the **UNLOCK** key. Once the controls and door are locked, there is no access to any cooking functions.

To unlock the oven door and control, press **UNLOCK** and follow directions on the screen. You will be shown a code to use for unlocking the doors and controls.

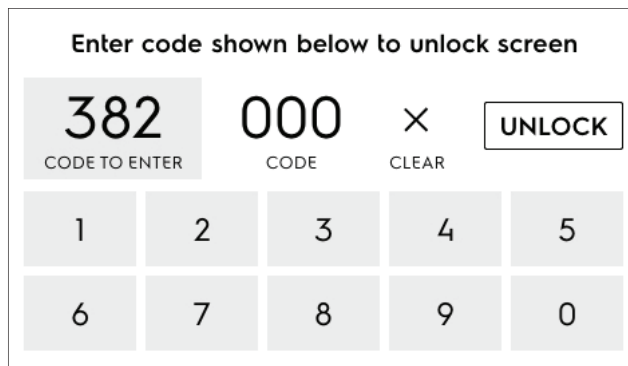

## About the Appliance

1. Scroll to **About the Appliance** and touch.
2. Touch headings to see information.

Important information about the appliance such as the the software version number and contact information for support is listed here.

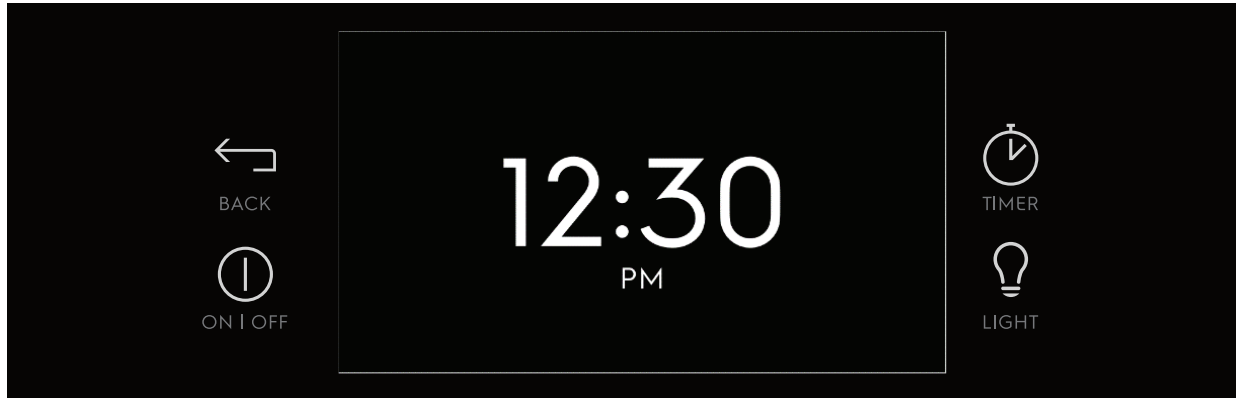

## ON / OFF

When **ON/OFF** is pressed, the display opens to the Quick Start screen.

## LIGHT

Press the Light key to turn the oven light on or off.

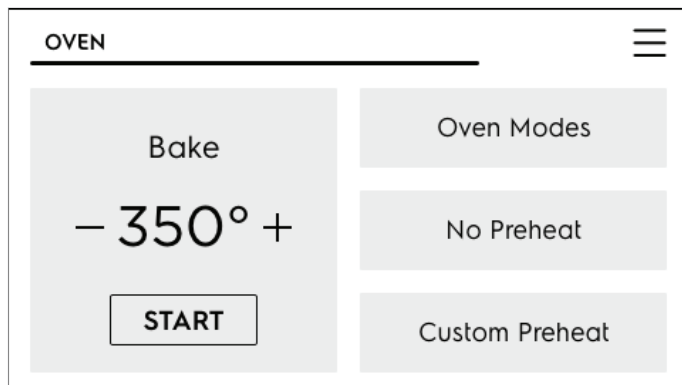

### NOTE

In addition to ON/OFF, touching the screen will also activate the display.

If the oven is on when **ON/OFF** is pressed, it will turn off completely, canceling any functions that are running at the time.

## BACK

Pressing the Back key will return to the previous screen without implementing any changes you may have selected.

## TIMER

Pressing Timer will access the timer function. The timer will count down the amount of time you specify, and a tone will sound when the timer reaches zero. You can set a timer from 1 minute to 11 hours and 59 minutes.

Enter the desired time and press **START**. While the timer is running, you can pause or cancel the countdown. You can also add or subtract time by pressing + or -.

**Table 1: Minimum and maximum control settings**

Feature	Mode	Min Temp/ Time	Max Temp/ Time
No Preheat		170°F (77°C)	550°F (288°C)
Bake		170°F (77°C)	550°F (288°C)
Broil		400°F (205°C)	550°F (288°C)
Air Fry		170°F (77°C)	550°F (288°C)
Sous Vide		100°F (38°C)	205°F (94°C)
Steam Bake		170°F (77°C)	550°F (288°C)
Steam Roast		170°F (77°C)	550°F (288°C)
Conv Bake		170°F (77°C)	550°F (288°C)
Conv Roast		170°F (77°C)	550°F (288°C)
Food Probe		140°F (60°C)	210°F (99°C)
Keep Warm		140°F (60°C)	200°F (93°C)
Bread Proof		100°F (38°C)	11:59 Hr./Min
Dehydrate		95°F (35°C)	170°F (77°C)
Timer		0:01 Min	11:59 Hr./Min.
Clock Time	12 Hr.	1:00 Hr./Min.	11:59 Hr./Min.
	24 Hr	0:00 Min	23:59 Hr./Min.
Delay Start		0:01 Min.	1:00 Hr./Min.
Cook Time	12 Hr.	0:01 Min	11:59 Hr./Min.
	24 Hr	0:01 Min	11:59 Hr./Min.
Self clean		2 hours	4 hours

# 20 SETTING OVEN CONTROLS

## Quick Start

When **ON/OFF** is pressed the display opens to the Quick Start screen.

From the Quick Start screen, you can immediately start the Bake function by pressing **START**. You can adjust the temperature by pressing **+** or **-**.

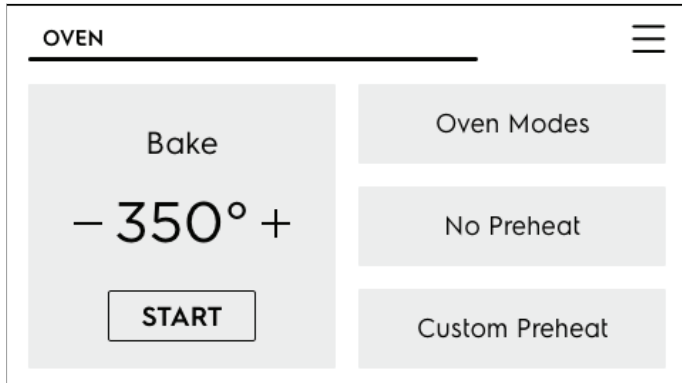

To select other cooking options, touch **Oven Modes** and scroll to the desired feature:

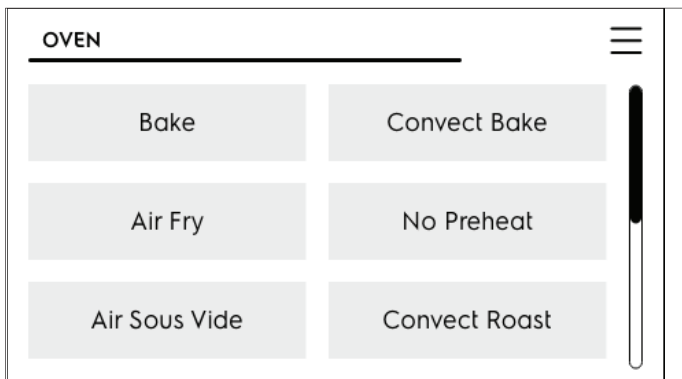

Use the scroll bar to find your oven mode as shown in the oven mode table on the right. When you select a cooking mode simply follow the tips for setting the particular mode.

**Important:** Valuable tips to help you get the best results are included in the display and also can be found in this Use & Care Manual.

## Modes

- Bake (page 21)
- Convection Bake (page 23)
- Air Fry (page 24)
- No Preheat (page 25)
- Slow Cook
  - Air Sous Vide (page 26)
  - Dehydrate (page 29)
  - Bread Proof (page 29)
  - Slow Cook (page 30)
- Convection Roast (page 30)
- Broil (page 32)
- Multi-Rack (page 34)
- Steam Bake (page 35)
- Steam Roast (page 36)
- Keep Warm (page 36)
- Delay Start (page 37)
- Self Clean (page 38)
- Steam Clean (page 41)
- Food Probe (page 42)

## Setting Bake

Bake uses heat that rises from the oven bottom for best baking results.

A reminder tone will sound indicating when the set bake temperature is reached and to place the food in the oven.

Bake may be set for any oven temperature between 170°F (77°C) to 550°F (288°C).

### CAUTION

Always use pot holders or oven mitts when using the oven. When cooking the oven interior, oven racks, and cooktop will become very hot which can cause burns.

## Baking Tips

- Fully preheat the oven before baking items like cookies, cakes, biscuits and breads.
- For all baking except layer cakes, pans should be pulled to the front of the rack. Place layer cake pans as shown.
- Use the convection bake function for best results when baking cookies or cakes on multiple racks.
- For best results when baking layer cakes using two oven racks, place racks in positions 2 (flat) and 5 (glide) and place pans centered on each rack.
- When using any single rack for baking cookies, cakes, biscuits, or muffins use rack position 3.
- Allow at least 2 inches (5 cm) of space between bakeware for proper air circulation.
- Leave oven lights off while baking.

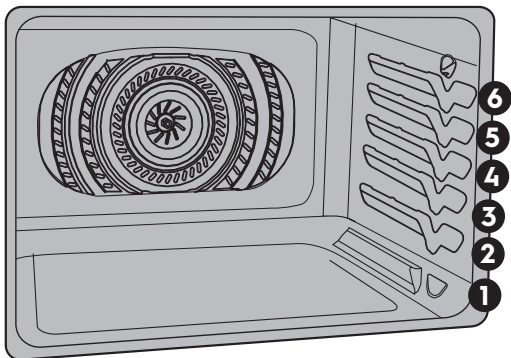

## To set Bake

1. Press **ON/OFF** key.

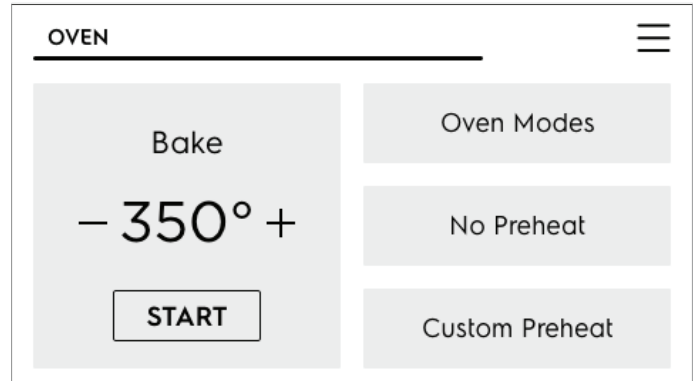

2. Touch **Oven Modes** and touch **Bake**. The default temperature 350°F will show in the display. You can also use the controls on the Quick Start screen.
3. To set the temperature to 375, use the numbered keys to program the new temperature of 375 and touch **START**.
4. The screen shows the current temperature and a **Cook Time** button.
5. Touch **Cook Time** to set a cooking time if needed.

**NOTE:** If a cook time is set the oven will turn off automatically when the time expires.

6. Touch **START**.
7. When cooking has ended, **Off** will be in display.
8. Press **ON/OFF** to return display to show the time of day.

To cancel cooking anytime touch **CANCEL**.

Press **ON/OFF** to turn off the oven and show time of day in the display.

To cancel cooking anytime touch **CANCEL**.

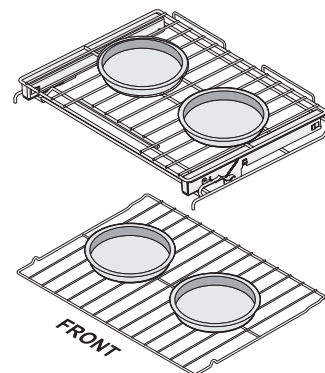

# 22 SETTING OVEN CONTROLS

---

## Setting Cook Time

Use Cook Time to set the amount of time needed for most oven functions. The oven will turn on immediately (or after a specified delay) and stop automatically after the set cook time ends.

In most cases you will see a cooking tip suggesting to set Cook Time after the oven is preheated.

### When the programmed cook time ends:

- **Off** will appear in the display window
  - an alert tone will sound
  - the oven will turn off automatically
- The **Off** message and an **OKAY** button will display until **OKAY** is touched.

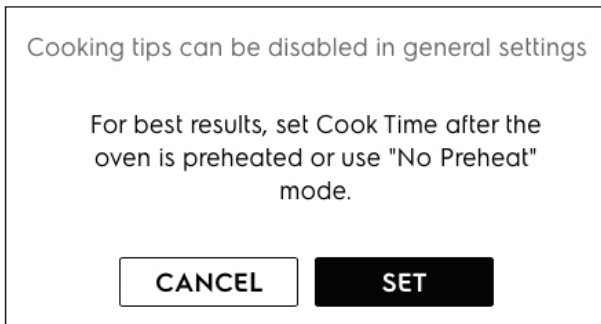

**NOTE:** The maximum cook time setting is 11 hours and 59 minutes unless the oven is set for continuous cooking.

### To change the oven temperature or cook time after baking has started:

- Touch **+** or **-** on either side of the set temperature.
- Touch **TEMP** to access the keypad.

## Convection Bake

Convection Bake uses a fan to circulate the oven's heat uniformly around the oven. This improved heat distribution allows for even cooking and browning results. Heated air flows around the food from all sides.

Convection bake may be set for any oven temperature between 170°F (77°C) and 550°F (288°C).

### Benefits of convection cooking include:

- Multiple rack baking.

### Convection baking tips:

- Use Convection Bake for best results when baking cookies and cakes on 2 racks.
- For best results it is recommended to preheat the oven before baking items like cookies, biscuits and breads and move pans to front of the racks.
- If your recipe is not written for convection baking, reduce the oven temperature by 25° or use Convection Convert option.
- No special pans or bakeware required.
- For cookies use the following racks:
- Single rack baking use 3 (flat rack).
- Two rack baking use 2 (flat) and 5 (glide).
- For baking cakes use the following rack positions and place bakeware as shown in Figure 4. In upper rack use position 4 (glide) or 5 (flat).
- Cookies and biscuits should be baked on pans with no sides or very low side to allow heated air to circulate around the food. Food items baked on pans with a dark finish will cook faster.
- Leave oven lights off while baking.

## Convection Convert

Convection Convert automatically reduces the oven temperature from what is specified in most baking recipes to compensate for the increased cooking efficiency of convection baking.

To set convection bake with a default oven set temperature of 325°F (163°C):

1. Select **Oven Mode** and scroll to **Convection Bake**.
2. Touch **Convection Bake**: Default oven temp of 325° appears.
3. An option for **Convection Convert** is visible on the screen. Using it will lower the oven temperature 25° to account for the increased efficiency of convection. If used, Convection Convert must be selected before pressing Start.
4. Touch **START**:
5. Option to set **Cook Time**.
6. Touch **START**.
7. Oven will turn off when **Cook Time** is complete.
8. Cooking has ended and **Off** will be in display.
9. Press **ON/OFF** to return display to show the time of day.

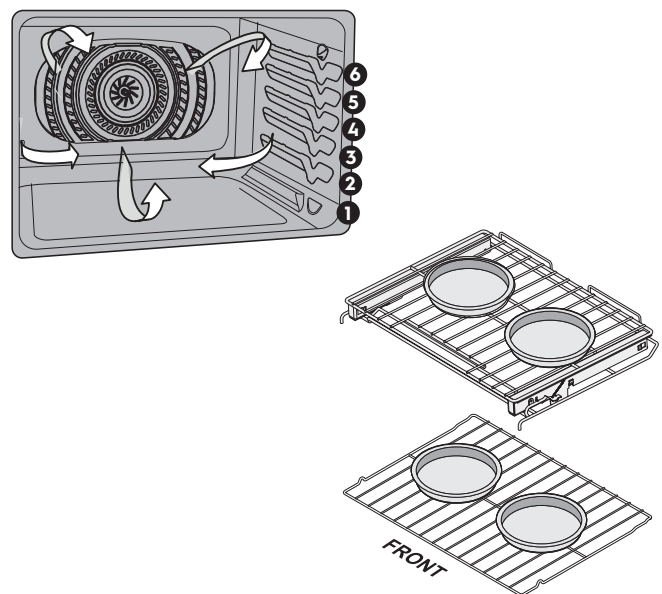
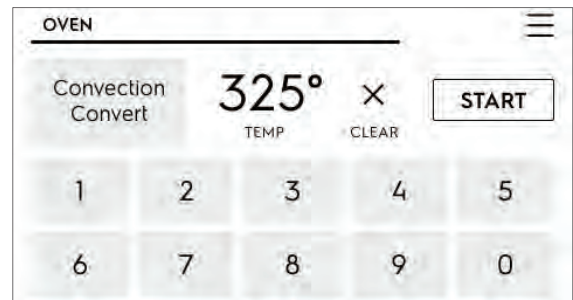

**Figure 3: Pan positions for best results when baking cakes on two racks.**

# 24 SETTING OVEN CONTROLS

## Air Fry

The Air Fry feature works best for single rack baking with packaged and convenience foods. It works well with most recipes and can be programmed for temperatures between 170°F and 550°F. Follow the recipe or package directions for food preparation quantity, time, and temperature.

### Important:

- Food should be arranged in single layers on the air fry tray and placed on rack position 3 for best results.
- When using the Air Fry tray, place a large cookie sheet on rack position 1 to catch any crumbs or drippings.
- Leave oven light off when baking.
- Food may need to be removed early and should be checked at minimum recommended bake time. However, frozen dense foods and items with cook times less than 15 minutes may require additional time.

### To set the Air Fry function:

1. Arrange food on rack as suggested.
2. Select **Air Fry** from Oven Modes.
3. Enter the suggested temperature for particular food. Touch **START**.
4. Press **START**. When preheat tone sounds place the tray on rack position 3 and to prevent smoke, place a baking sheet on rack position 1 below the Air Fry Tray.
5. If setting a Cook Time, set after the oven is preheated. Cook time turns off Air Fry when time is finished. **NOTE:** Setting the timer for the minimum suggested time after preheat is a good option and checking food for doneness.

6. When cook time ends **Off** will be in display.
7. Press **ON/OFF** to return display to show the time of day.

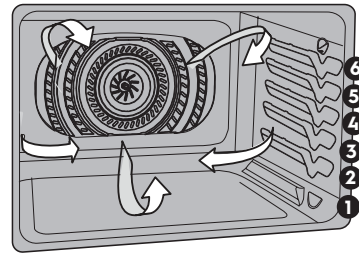

Frigidaire offers an optional Air Fry Tray specifically designed to deliver superior performance.

### Some Benefits of the Optional Air Fry Tray:

- Tray optimized for oven space.
- Fits in the dishwasher for easy clean up.
- Higher yield than countertop models.
- Frees up countertop space.
- Compatible with convection ovens.
- The optional Air Fry tray may be purchased from [www.frigidaire.com](http://www.frigidaire.com).

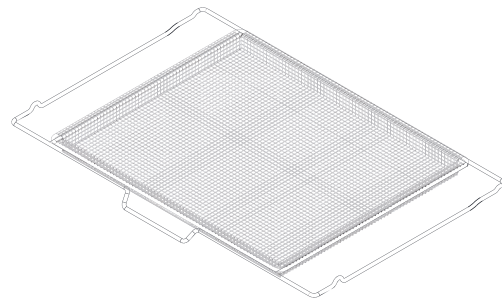

Figure 4: Air Fry Tray

Table 2: Air Fry Table

Food Type	Quantity (oz.)	Temperature	Cook Time (mins)
Frozen Tater Tots	48	450°F - 232°C	29-33
Frozen Golden Fries	48	425°F - 218°C	25-35
Frozen Chicken Nuggets	48	400°F - 205°C	13-15
Frozen Crispy Chicken Strips	48	400°F - 205°C	20-22
Frozen Hot Wings Bone-In	48	450°F - 232°C	25-28
Frozen Chicken Wings	48	375°F - 190°C	60-65
Fresh Chicken Wings	48	450°F - 232°C	30-40



## No Preheat

No Preheat is available for single rack baking with packaged and convenience foods and can be used with regular recipes also. No Preheat may be used with temperatures between 170°F and 550°F. Follow the recipe or package directions for food preparation time and temperature.

During No Preheat function, the oven elements will cycle on and off. The convection fan will turn on and stay on until No Preheat is canceled. Depending on your preference for doneness cooking times may vary. Watch food closely.

### CAUTION

Always use pot holders or oven mitts when using the oven. When cooking the oven interior, oven racks, and cooktop will become very hot which can cause burns.

#### Important:

- Always place food on rack position 3.
- Place the food with the pan or bakeware to the front of the oven rack.
- When using No Preheat, use bakeware with low or no sides. This allows the air to circulate around the food evenly.
- Leave oven light off when baking.
- Food that comes in strips, such as fish sticks and chicken tenders, should be placed on the pan with the ends pointing to the sides of the oven. Follow the package directions for food preparation time and temperature.
- Food may need to be removed early and should be checked at minimum recommended cook time.
- No Preheat works best when cooking foods longer than 10 minutes. If directions call for a shorter cooking time, a few extra minutes may be required for optimal cooking results.
- Do not open the oven door often. Opening the door will reduce the temperature in the oven and may increase cook time.
- Leave oven lights off while cooking.

#### To set the no preheat temperature for 350°F:

1. Arrange the interior oven racks.
2. Press **ON/OFF** key.
3. Touch **Oven Modes** and scroll to **No Preheat**.
4. Follow No Preheat tips and set temperature or use 350°F (default).
5. Touch **START**.

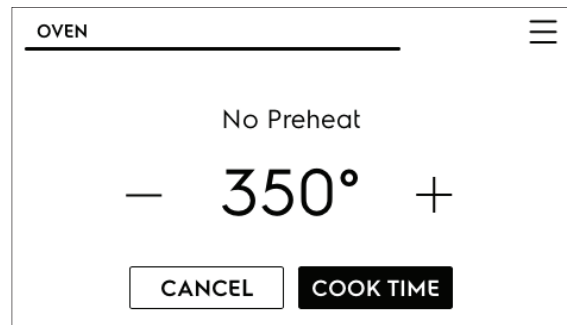

6. Set **Cook Time** if needed.
7. Touch **START**.

- NOTE:** If a cook time is set the oven will turn off automatically when the time expires. Foods with a cook time under 10 minutes may need extra time.
8. When cooking has ended, **Off** will be in display.
  9. Press **ON/OFF** to return display to show the time of day.

To cancel cooking anytime touch **CANCEL**.

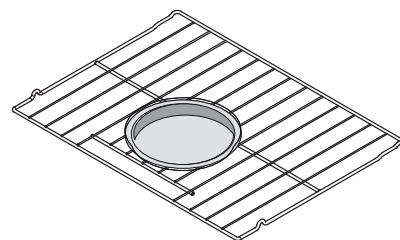
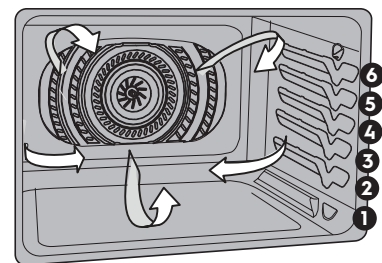

# 26 **SETTING OVEN CONTROLS**

---

## **Air Sous Vide**

Air Sous Vide is ideal for cooking meats to achieve tenderness without overcooking.

### How Sous Vide Works

Sous vide is a French phrase meaning “under vacuum”. In sous vide cooking, food is vacuum-sealed in plastic pouches, which are then placed in a cooking medium of hot water or air.

Your appliance uses hot air circulating around sealed pouches to cook food slowly at relatively low temperatures: 100°F to 205°F (38°C to 94°C). Sous vide cooking is not fast, but with a little planning, it can be very easy.

### **Advantages of Sous Vide**

- Food does not lose flavor or aroma due to evaporation.
- Vitamins and minerals do not escape during cooking.
- The low cooking temperature leaves meat and fish more tender.
- Less spice is needed, as food keeps more of its natural flavor.
- The low cooking temperature greatly reduces the risk of overcooking. The food never gets hotter than the intended serving temperature.
- Timing is less critical. If different dishes are finishing at different times, food that has reached serving temperature can wait, since it stays at serving temperature in the cooking medium.

## **Food Safety**

Because sous vide cooks at relatively low temperatures, safe food handling is especially important.:

- Always keep raw food in safe conditions before you start cooking.
- Clean the raw food before you start cooking.
- Use Table 1, “Recommended Sous Vide Cook Settings,” to find the recommended cooking time and temperature for the food.
- Only use temperatures below 140°F (60°C) to cook foods that can be safely eaten raw.
- Food should be between 34°F and 37°F (normal refrigerator temperatures) when preparing to place food in sous vide vacuum pouch.
- Sous vide dishes are best served immediately after cooking. If food is not served immediately, use an ice bath to chill it quickly and then keep it refrigerated for up to 3 days.
- Do not use sous vide to reheat leftovers.
- Do not allow raw food to contact cooked food during preparation. Do not use the same tools on different food items without washing them.
- If the recipe includes raw eggs, keep the whites and yolks from touching the outsides of the shells.
- Blanching in boiling water or searing in a pan before sous vide cooking can destroy surface bacteria to improve food safety.
- Do not use Delay Start with the Sous Vide function.
- Do not use a meat probe with the Sous Vide function. Food needs to be sealed air-tight in a pouch for sous vide cooking.

## Vacuum Sealing

Sous vide cooking in your oven requires a vacuum sealer and vacuum pouches. The pouch needs to be sealed so no air or liquid can leak out. A pouch that leaks will produce poor cooking results and may produce smoke and residue that can burn during future cooking or when using self-clean. Follow the instructions that come with your sealer and pouches.

- Use pouches that are specified for your sealer and for sous vide cooking.
- Do not reuse vacuum pouches.
- Put food in one layer in the pouch for even cooking.
- It is recommended to use one food portion per vacuum pouch.
- For most sous vide cooking, use the highest vacuum setting for best cooking results.
- Make sure that the closure of the pouch is clean to get a good seal. If cooking at higher temperatures (above 160° F / 71° C), double-seal the pouch.
- Vacuum pouches are solely for sous vide cooking and should not be used for regular baking or broiling.

## Sous Vide Cooking

1. Prepare
  - Start with the freshest, highest quality food possible.
  - Clean and cut the ingredients.
2. Package
  - Place the ingredients in the plastic pouch for your vacuum sealer. Add seasonings for cooking.
  - Note: If cooking multiple items at once, you may want to write the contents on the outside of the pouches before filling and sealing them.
  - Vacuum seal the pouch, removing as much air as possible. Verify that you have achieved an air-tight seal.
  - If not cooking immediately, store the pouch in a refrigerator until ready to cook.

## To cook Air Sous Vide:

1. Touch **Oven Modes** and scroll to **Slow Cook**, then choose **Air Sous Vide** from the sub-menu.
2. Touch **Air Sous Vide**: display shows 130°F (54°C) setting as default.



3. Set desired temperature.
4. Touch **START**.

**IMPORTANT:** Since sous vide cooking allows for a suggested minimum cooking time and a target time, it is recommended to set the timer to at least the minimum time or to any time up to the target suggested time. With sous vide cooking, there is a maximum cooking time which allows the user more flexibility when cooking with no specific end time.

**Note:** Use the settings recommended for the type of food in Table 3 on page 28.

5. Finish
  - Open the plastic pouch and remove the food.
  - You may finish the food with a final searing or grilling to achieve a nice crust and roast flavor.
  - Add final seasonings or sauces if needed.
  - Serve.

## CAUTION

Even though sous vide cooks at relatively low temperatures, use care when handling the pouch and its contents, which will be hot to the touch.

Only use temperatures below 140°F (60°C) for cooking foods that can be safely eaten raw.

## IMPORTANT

The U.S. Department of Agriculture states, “Rare fresh beef is popular, but you should know that cooking it to only 140°F (60°C) means some food poisoning organisms may survive.” (Source: Safe Food Book, Your Kitchen Guide, USDA) The lowest temperature recommended by the USDA is 145°F (63°C) for medium rare fresh beef. For beef medium 160°F, well done 170°F (77°C). Visit the USDA Food Safety and Inspection website at [www.fsis.usda.gov](http://www.fsis.usda.gov).

# 28 SETTING OVEN CONTROLS

Table 3: Sous Vide Table

Food	Doneness	Temperature	Cooking Time		
			Minimum	Target	Maximum
<b>Beef</b>					
Steak	Rare	130° F / 54°-55° C	2 hours	3 hours	4 hours
Steak	Medium Rare	135° F / 57°-58° C	2 hours	3 hours	4 hours
Steak	Medium	145° F / 62°-63° C	2 hours	3 hours	4 hours
Steak	Medium Well	150° F / 65°-66° C	2 hours	3 hours	4 hours
Steak	Well	160° F / 71°-72° C	2 hours	3 hours	4 hours
Roast	Rare	135° F / 57°-58° C	6 hours	7 hours	16 hours
Roast	Medium Rare	140° F / 60° C	6 hours	7 hours	16 hours
Roast	Medium	150° F / 65°-66° C	6 hours	7 hours	16 hours
Roast	Medium Well	155° F / 68°-69° C	6 hours	7 hours	16 hours
Roast	Well	160° F / 71°-72° C	6 hours	7 hours	16 hours
Chuck/Brisket	Rare	140° F / 60° C	20 hours	24 hours	48 hours
Chuck/Brisket	Medium Rare	150° F / 65°-66° C	20 hours	24 hours	48 hours
Chuck/Brisket	Well	180° F / 82°-83° C	20 hours	24 hours	48 hours
<b>Pork</b>					
Chop	Medium	150° F / 65°-66° C	2 hours	3 hours	4 hours
Chop	Well	160° F / 71°-72° C	2 hours	3 hours	4 hours
Roast	Medium	150° F / 65°-66° C	2 hours	3 hours	4 hours
Roast	Well	180° F / 82°-83° C	2 hours	3 hours	4 hours
Shoulder/Belly	Medium	150° F / 65°-66° C	10 hours	24 hours	48 hours
Shoulder/Belly	Well	180° F / 82°-83° C	10 hours	24 hours	48 hours
<b>Chicken</b>					
Parts	Tender	170° F / 76°-77° C	2 hours	2-1/2 hours	4 hours
<b>Fish</b>					
Steak	Tender	105° F / 40°-41° C	1 hour	1-1/2 hours	2 hours
Steak	Flaky	125° F / 51°-52° C	1 hour	1-1/2 hours	2 hours
Steak	Well	145° F / 62°-63° C	1 hour	2 hours	2 hours
Fillet	Tender	105° F / 40°-41° C	45 mins	1 hour	1 1/2 hours
Fillet	Flaky	125° F / 51°-52° C	45 mins	1 hour	1 1/2 hours
Fillet	Well	145° F / 62°-63° C	45 mins	1 hour	1 1/2 hours
<b>Vegetables</b>					
Squash	Cubes	180° F / 82°-83° C	1 hour	1 1/2 hours	4 hours
Roots	Sliced/Cubes	180° F / 82°-83° C	1 hour	1 1/2 hours	4 hours
Potatoes	Sliced/Cubes	200° F / 93°-94° C	1 hour	1 1/2 hours	4 hours
<b>Fruits</b>					
Warm/Ripe	Sliced/Cubes	155° F / 68°-69° C	45mins	105 mins	2 1/2 hours
Soft	Purees	180° F / 82°-83° C	15 mins	30 mins	90 minutes
Steak thickness based on 1.5". Thicker cuts may require longer times.					

## Dehydrate

For best results when dehydrating food use the Air Fry tray which allows air to circulate all around the food for faster preservation.

### Tips

- Always use clean equipment and utensils.
- Keep meat and poultry refrigerated -- 40°F (4°C) or slightly below -- before dehydrating.
- Cut food in evenly sized pieces. Slices should be even and ¼ to ½ inch thick. This will ensure all pieces are dehydrated at same time.
- Use good quality fruits, vegetables, and meats. Overripe or bruised fruits and vegetables may turn black while dehydrating.
- Use lean cuts of meat or trim off excess fat.
- Use a paper towel to dry meat before dehydrating.
- Store dehydrated foods in airtight containers. If moisture appears in containers, the food was not dehydrated properly.
- Follow USDA recommendation when dehydrating.

### To set Dehydrate:

1. Arrange food in a single layer on the Air Fry tray.
2. Touch **Oven Modes** and scroll to **Slow Cook**, then choose **Dehydrate** from the sub-menu.
3. Set dehydrate temperature (between 95°F -170°F).
4. Touch **START**.
5. Press **ON/OFF** to end cooking and return display to show the time of day.

### NOTE

Check food for doneness. If any moisture is present, allow food to dehydrate longer.

## Bread Proof

Bread proofing creates the best conditions for yeast to multiply and cause your dough to rise.

1. Touch **Oven Modes** and scroll to **Slow Cook**, then choose **Bread Proof** from the sub-menu.
2. Touch **Bread Proof**: Shows **Bread Proof 100°F (38°C)**.
3. Touch **START**.

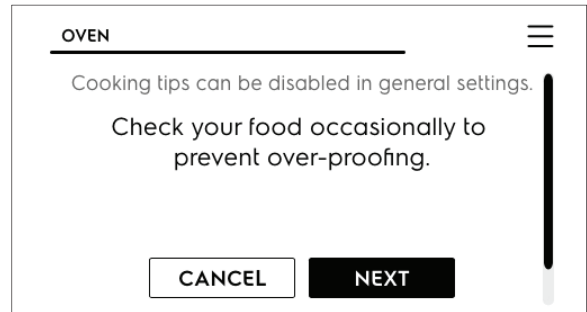

### NOTE

Check often to prevent over-proofing.

**Table 4: Dehydration Temp and Time Suggestions**

Food	Temperature	Hours	Food	Temperature	Hours		
Herbs, flowers	95°F - 35°C	6-10	Citrus Peel 8 - 15 hours	135°F - 57°C	8-15		
Vegetables	125°F - 52°C	8-20	Fruit	145°F - 63°C	5-7		
Tomatoes			6-12			Apples	8-20
Peppers			6-12			Bananas	8-20
Mushrooms			6-12			Strawberries	12-18
Meat	165°F - 74°C	6-18	Fish	145°F - 63°C	8-12		
Root Vegetables	165°F - 74°C	6-10	Fruit Rolls/Leather	165°F - 74°C	8-18		
Carrots			10-15			Nuts and Seeds	150°F - 66°C
Potatoes							

# 30 SETTING OVEN CONTROLS

## Slow Cook

Use Slow Cook for foods that will cook or braise at low temperature for a long period of time.

### For best results when using Slow Cook:

- Completely thaw all frozen foods before cooking.
- When using a single oven rack, place in oven rack position 2 or 3. Position racks to accommodate the size of various bakeware when cooking multiple food items.
- Do not open the oven door often or leave the door open when checking foods. If the oven heat escapes often, the Slow Cook time may need to be extended.
- Cover to keep foods moist or use a loose or vented type cover to allow foods to turn crisp or brown.
- Roasts may be left uncovered so browning can occur. Cook times will vary depending on the weight, fat content, bone, and the shape of the roast. Preheating the oven will not be necessary when using the Slow Cook feature.
- Add any cream or cheese sauces during the last hour.

Slow cooking meats may result in the outside of the meat turning dark; this is normal.

### To set Slow Cook:

1. Touch **Oven Modes** and scroll to **Slow Cook**, then choose **Slow Cook** from the sub-menu.
2. The display shows 175°F (79°C) setting as default. Use the numbered keys to program a different temperature if desired. Touch **START**.
3. The screen shows the current temperature and a **Cook Time** button.
4. Touch **Cook Time** to set a cooking time if needed.  
**NOTE:** If a cook time is set, the oven will turn off automatically when the time expires.
5. Touch **START**.
6. When cooking has ended, **Off** will be in display. Press **OK** to return to the start screen.

Press **ON/OFF** to turn off the oven and show time of day in the display.

To cancel cooking at any time, touch **CANCEL**.

## Convection Roast

Convection roast combines a cook cycle with the convection fan and elements to rapidly roast meats and poultry. Heated air circulates around the meat from all sides, sealing in juices and flavors. Meats cooked with this feature are crispy and brown on the outside while staying moist inside.



### WARNING

Should an oven fire occur, close the oven door and turn the oven off. If the fire continues, use a fire extinguisher. Do not put water or flour on the fire. Flour may be explosive and water can cause a grease fire to spread and cause personal injury.



### CAUTION

Always use pot holders or oven mitts when using the oven. When cooking, the oven interior, oven racks, and cooktop will become very hot which can cause burns.

### To use convection roast at a temperature of 350°F (177°C):

1. Touch **Oven Mode** and scroll to **Convection Roast**.
2. Touch **Convection Roast**.
3. **Set** desired temperature or use default of **350°**.
4. Touch **START**.
5. Option to set **Cook Time**.
6. Touch **START**. Preheating the oven is not necessary.
7. When cooking is completed or to cancel Convection Roast press **ON/OFF**.

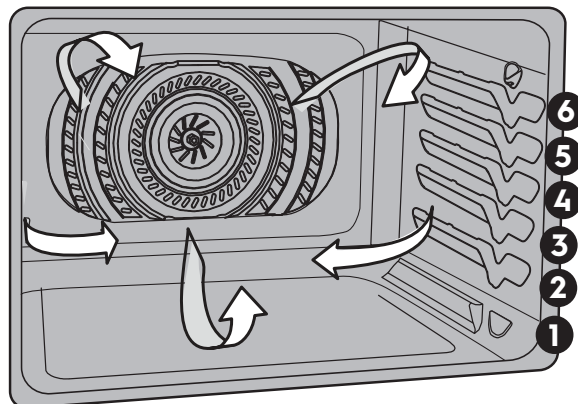

Figure 6: Convection roasting on lower oven racks

**Convection Roasting tips:**

- Preheating for convection roast is not necessary for most meats and poultry.
- Arrange oven racks so meat and poultry are on the lowest rack of the oven.
- Since convection roast cooks faster, may be able to reduce cook times as much as 25% from the recommended time of your recipe (check the food at this time). Then if needed, increase cook time until the desired doneness is obtained.
- Do not cover foods when dry roasting - covering will prevent the meat from browning properly.
- When cooking meats use the broiler pan and insert. The broiler pan will catch grease spills and the insert helps prevent grease splatters.

**Table 5: Convection Roasting recommendations**

Meat		Weight	Oven Temp	Internal Temp	Mins per lb
Beef	Standing rib roast*	4 to 6 lb.	350°F (177°C)	*160°F (71°C)	25-30
	Rib eye roast*	4 to 6 lb.	350°F (177°C)	*160°F (71°C)	25-30
	Tenderloin roast	2 to 3 lb.	400°F (204°C)	*160°F (71°C)	15-25
Poultry	Turkey whole**	12 to 16 lb.	325°F (163°C)	180°F (82°C)	8-10
	Turkey whole**	16 to 20 lb.	325°F (163°C)	180°F (82°C)	10-15
	Turkey whole**	20 to 24 lb.	325°F (163°C)	180°F (82°C)	12-16
	Chicken	3 to 4 lb.	350°F-375°F (177°C-191°C)*	180°F (82°C)	12-16
Pork	Ham roast, fresh	4 to 6 lb.	325°F (163°C)	160°F (71°C)	30-40
	Shoulder blade roast	4 to 6 lb.	325°F (163°C)	160°F (71°C)	20-30
	Loin	3 to 4 lb.	325°F (163°C)	160°F (71°C)	20-25
	Pre-cooked ham	5 to 7 lb.	325°F (163°C)	160°F (71°C)	30-40

\* The U.S. Department of Agriculture states, "Rare fresh beef is popular, but you should know that cooking it to only 140°F (60°C) means some food poisoning organisms may survive." (Source: Safe Food Book, Your Kitchen Guide) The lowest temperature recommended by the USDA is 145°F (63°C) for medium rare fresh beef. For well done 170°F (77°C)\*\* Stuffed turkey requires additional roasting time. Shield legs and breast with foil to prevent over browning and drying of the skin.

# 32 SETTING OVEN CONTROLS

## Setting Broil

Use the broil function to cook foods that require direct exposure to radiant heat for optimum browning results. Broiling may produce smoke. If smoke is excessive, place food further away from the heating element.

The broil feature preset to 550°F. Broil may be set at any temperature between 400°F (205°C) and 550°F (288°C).

### WARNING

Should an oven fire occur, close the oven door and turn the oven off. If the fire continues, use a fire extinguisher. Do not put water or flour on the fire. Flour may be explosive and water can cause a grease fire to spread and cause personal injury.

### CAUTION

Always use pot holders or oven mitts when using the oven. When cooking, the oven interior, oven racks, and cooktop will become very hot which can cause burns.

### IMPORTANT

Broiler pans and inserts allow the grease to drain away from the high heat of the broiler. Do not use the pan without the insert. Do not cover the insert with foil - the exposed grease could ignite.

## To set broil with the default broil oven temperature of 550°F (288°C):

1. Arrange the oven racks when cool. For optimum browning results, preheat oven for 2 minutes before adding food.
2. Select **Oven Mode** and scroll to **Broil**.
3. Default **550°** appears.
4. If lower broil temperature is needed use keypad to select between 400° and 550°.

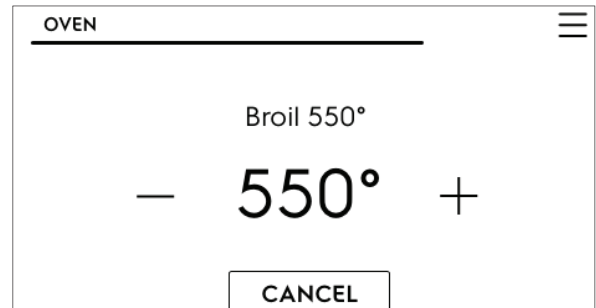

5. Press **START**. Broil with oven door closed.
6. Broil on one side until food is browned; turn and broil other side until done to your satisfaction.
7. When finished broiling, press **ON/OFF**.

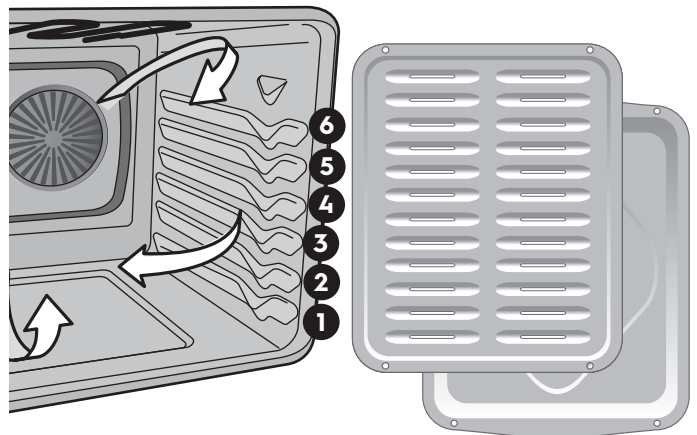



**Important notes:**

- Always arrange oven racks when the oven is cool.
- For best results when broiling, use a broil pan with broil pan insert designed to drain the fat from the food and help avoid spatter and reduce smoking.
- When broiling, always pull the oven rack out to the stop position before turning or removing food.

**Table 6: Broil recommendations**

Food item	Rack Position	Temp	Cook time in minutes		Internal Temperature	Doneness
			1st side	2nd side		
Steak 1" thick	5	550°F (288°C)	4:00	4:00	140°F (60°C)	Rare**
Steak 1" thick	5	550°F (288°C)	6:00	4:00	145°F (63°C)	Medium
Steak 1" thick	5	550°F (288°C)	7:00	5:00	160°F (71°C)	Medium-well
Steak 1" thick	5	550°F (288°C)	8:00	6:00	170°F (77°C)	Well
Pork Chops 3/4 "thick	5	550°F (288°C)	12:00	10:00	170°F (77°C)	Well
Chicken - Bone In	5	450°F (232°C)	20:00	10:00	170°F (77°C)	Well
Chicken Boneless	5	450°F (232°C)	8:00	6:00	170°F (77°C)	Well
Fish	5	550°F (288°C)	as directed		170°F (77°C)	Well
Shrimp	5	550°F (288°C)	as directed		170°F (77°C)	Well
Hamburger 1" thick	5	550°F (288°C)	9:00	7:00	145°F (63°C)	Medium
Hamburger 1" thick	5	550°F (288°C)	10:00	8:00	170°F (77°C)	Well

The U.S. Department of Agriculture states, "\*\*Rare fresh beef is popular, but you should know that cooking it to only 140°F (60°C) means some food poisoning organisms may survive." (Source: Safe Food Book, Your Kitchen Guide, USDA Rev. June 1985.) The lowest temperature recommended by the USDA is 145°F (63°C) for medium rare fresh beef. For well done 170°F (77°C). All cook times shown are after 2 minutes of preheating.

# 34 SETTING OVEN CONTROLS

## Multi-Racks

Multi-Rack is for baking on up to two racks while following recommended time and temperature. The oven will make adjustments for best results.

**IMPORTANT:** Be sure to use suggested rack positions before setting oven.

- Follow recipe for time and temp and the oven will make needed adjustments for best performance.
- Fully preheat the oven for best results.
- Pans and pizzas should be pulled to the front of the rack.
- Allow at least 2 inches (5 cm) of space between bakeware for proper air circulation.
- Leave oven lights off while baking.
- Use flat rack in position 1 and glide rack in position 4.

## To use Multi-Rack:

1. Arrange the oven racks when cool.
2. Select **Oven Mode** and scroll to **Multi Racks**.
3. Touch **Multi Racks**.
4. Default **350°** appears. Set another temperature if desired.
5. Touch **START**.
6. Set **Cook Time** if needed.
7. Press **START**.
8. When Cook Time ends the oven turns off automatically.
9. Cooking has ended and Off will be in display.
10. Press **ON/OFF** to return display to show the time of day.

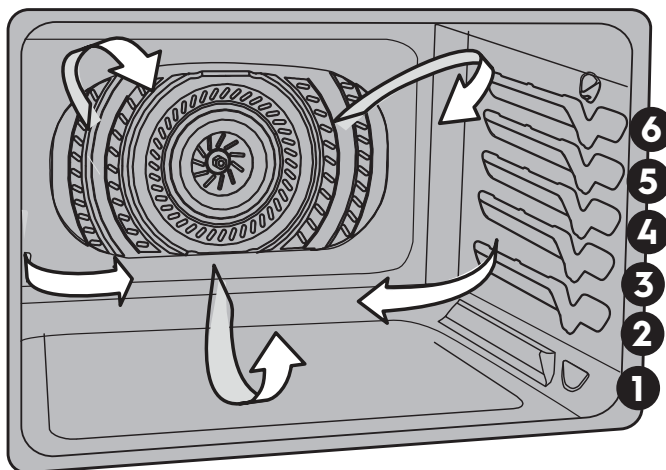

## Cooking with Steam

**Note:** More moisture will be present than during conventional baking or roasting. Moisture could condense on the handle or in the door, and depending on the conditions in your kitchen possibly drip onto the floor.

### Steam Cooking Tips:

#### Oven Positioning

- Use flat rack in the position in the oven for most foods for Steam Roast.
- Lowest position for poultry.

#### Preparing

- Use 2- $\frac{1}{2}$  cups of water for steam bake and steam roast. If steam functions are frequently used, use distilled water.
- Using water container, pour water slowly onto the bottom of oven cavity while still cool.
- Never add water if the oven is warm.
- Never add water during a Steam Bake or Steam Roast cycle.

#### While in Use

- When using Steam, follow the recipe for preheating, cook time, and cook temperature. If the original recipe did not use steam, reduce the temperature by 25°F (14°C), but not below 325°F (163°C).
- Always start with a cold oven.
- Preheating is not necessary when using steam roast.

#### Cleaning

- With a paper towel lightly soaked in distilled white vinegar, wipe out bottom of oven cavity after the oven is cooled or before each use.
- Use the self clean function to clean heavily soiled areas.
- If residue remains after self clean, pour a thin layer of distilled white vinegar onto the bottom of the oven cavity. Allow to sit for 30 minutes. Wipe out vinegar.

## Steam Bake

Steam creates the best conditions for baking bread on a single rack. Baked goods will have improved browning and texture and is recommended for baking moist and flavorful breads and pastries such as baguettes and croissants.

Use flat rack in position 3 for best results for Steam Bake. Pans should be pulled to the front of the rack.

### To set Steam Bake:

1. Select **Oven Modes** and scroll to **Steam Bake**.
2. Add 2- $\frac{1}{2}$  cups of water to oven bottom as directed.
3. Touch **NEXT** and follow Steam Bake instruction for setting temperature.
4. Touch **START**.
5. Set **Cook Time**. (Suggests waiting to set Cook Time until oven preheats.)
6. When **Cook Time** ends oven turns off automatically.
7. **Cooking has ended** and **Off** will be in display.
8. Press **ON/OFF** to return to show the time of day.



### CAUTION

Do not use Steam Bake for cooking at temperatures below 325°F (163°C).



### IMPORTANT

Stand to the side of the oven when opening to allow any steam to escape.



### NOTE

The cooling fan will run on high during steam cooking.

# 36 SETTING OVEN CONTROLS

## Steam Roast

Steam creates the best conditions for roasting proteins. Meats will be crisp outside and juicy inside.

Steam Roast is recommended for meat or poultry. Use flat rack in position 1 for best results for Steam Bake.

### To set Steam Roast:

1. Select **Oven Modes** and scroll to **Steam Roast**.
2. Add 2- $\frac{1}{2}$  cups of water to the bottom of the oven as directed.
3. Touch **NEXT** and follow Steam Roast instruction for setting temperature.
4. Touch **START**.
5. When **Cook Time** ends oven turns off automatically.
6. **Cooking has ended** and **Off** will be in display.
7. Press **ON/OFF** to return display to show the time of day.

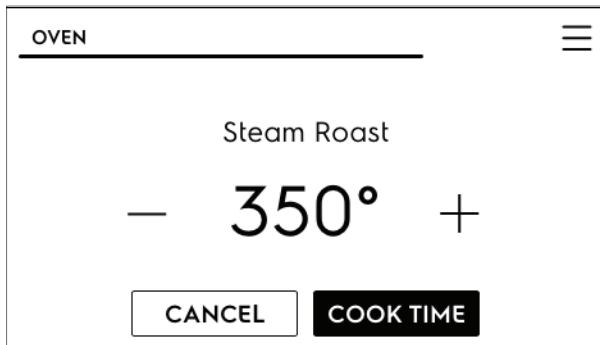

## ! CAUTION

Do not use Steam Roast for cooking at temperatures below 325°F (163°C).

## ➔ IMPORTANT

Stand to the side of the oven when opening to allow any steam to escape.

## ➔ NOTE

The cooling fan will run on high during steam cooking.

## Keep Warm

Keep Warm should only be used with foods that are already at serving temperatures. Keep warm will keep cooked foods warm and ready for serving after cooking has finished.

Keep warm will keep the oven temperature at 140° F - 200° F (60°C - 93°C).

### To set Keep Warm:

1. If needed, arrange oven racks and place cooked food in oven.
2. Press **Oven Modes** and scroll to **Keep Warm**.
3. Touch **Keep Warm**.
4. Set desired temperature.
5. Press **START**.
6. **Keep Warm** will turn off when canceled.

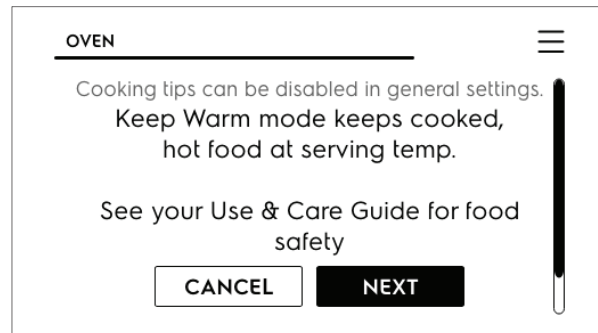

### Setting Delay Start

Delay Start allows a delayed starting time only for Bake, Convection Bake, No Preheat, Convection Roast, Steam Roast, Steam Clean, and Self Clean. Prior to setting a delay start, be sure the time of day is set correctly. The maximum delay for a Delay Start is one hour (12 hours for Self Clean or Steam Clean).

1. Press **ON/OFF** key and touch **Oven Modes**.

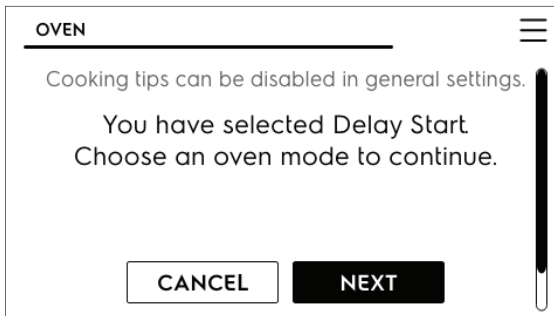

2. Scroll to **Delay Start** and touch.
3. Follow the information on the screen to set delay time, temperature, and cook time.

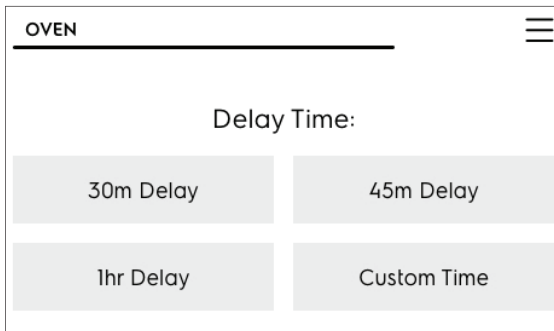

When the Delay Start time is reached, the oven will turn on and begin cooking. The screen will show the oven temperature.

When Cook Time (if used) ends, **Cooking is over** and **Off** and **OKAY** will appear in the display window, and the oven will shut off automatically.

The oven control will sound tones as a reminder until the **OKAY** is pressed.

**! WARNING**

**Food Poisoning Hazard.** Do not let food sit for more than one hour before or after cooking. Doing so can result in food poisoning or sickness.



## To set a self clean cycle:

1. Be sure the oven is empty and all oven racks are removed. Remove all items from the oven. Be sure oven door is completely closed.
2. Touch **Oven Modes** and scroll to **Self Clean**.
3. Touch **Self Clean** and select 2 hour, 3 hour, or 4 hour clean time.
4. Press **TIMER** to start the self clean cycle.

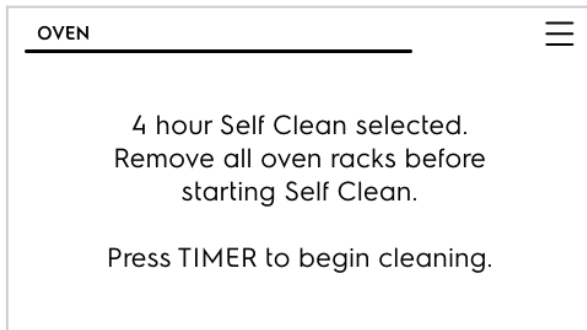

When the oven is set to run a self-clean cycle, the motor door lock will begin locking the oven door. Do not open the oven door while the lock motor is running or when any locking indicators or displays are showing. The oven door is completely locked in about 15 seconds. Once the oven door has locked, CLEAN will appear in the display indicating self clean has started.

Do not force the oven door open when self-clean is active. This can damage the automatic door-locking system. Use caution when opening the door after self-clean cycle is complete; the oven may still be very hot.

## When the self clean cycle has completed:

1. **CLEAN** message will turn off, and **Hot** will appear in display window. The oven door will remain locked while the oven cools.
2. Once the oven has cooled down (about 1 hour) and **Hot** is no longer displayed, the oven door may be opened.
3. When the oven interior has completely cooled, wipe away any residue or powdered ash with a damp cloth or paper towel.

# 40 SETTING OVEN CONTROLS

## Setting Delay Start Self Clean

To start a delay self clean with default clean time of 3 hours.

1. Press **ON/OFF** key and touch **Oven Modes**.
2. Scroll and touch **Delay Start**.

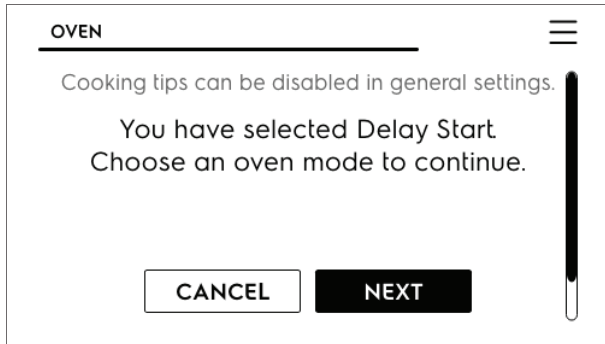

3. Touch **NEXT** and scroll Oven Modes to **Self Clean**. Follow the information on the screen to set delay time, self clean time.

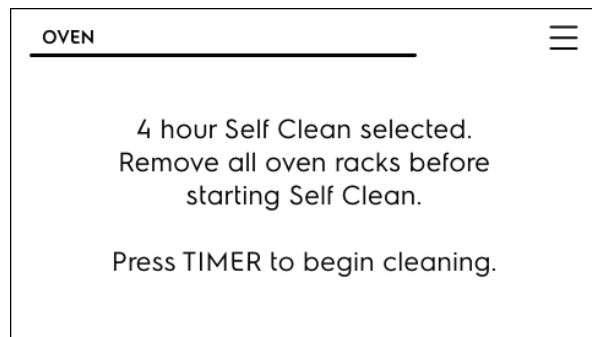
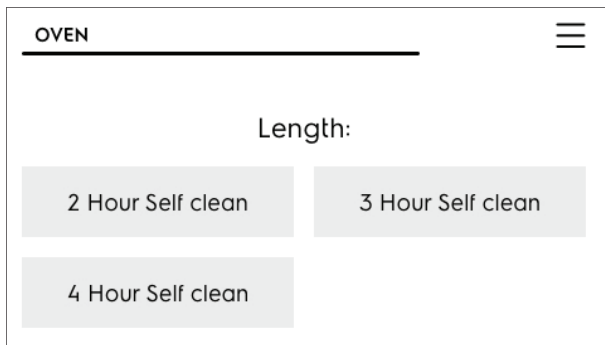

**If it becomes necessary to stop self clean when active:**

- Press **OFF**.
- If self clean has heated the oven to a high temperature, allow enough time for the oven to cool.
- Before restarting self clean, be sure to read important notes below.

### Important notes

- If self clean was active and then interrupted by a power failure or canceled before the oven was thoroughly cleaned, it may be necessary to run another self clean cycle.
- If the oven temperature was high enough when self clean was interrupted the oven control may not allow another self clean cycle to be set for up to 4 hours.



## Steam Clean

The Steam Clean feature offers a chemical free and time saving method to assist in the routine cleaning of small and light soils. For heavier baked on soils use the Self Clean feature.

### CAUTION

Do not add bleach, ammonia, oven cleaner, or any other abrasive household cleaners to the water used for Steam Clean.

Before cleaning any part of the oven, be sure all controls are turned off and the oven is cool. The oven may be hot and can cause burns.

Be sure the oven is level and cool before starting Steam Clean. If the oven temperature is above room temperature a triple beep will be heard and the function will not start. Steam Clean produces best results when started with a cool oven.

#### To set a Steam Clean cycle:

1. Remove all racks and oven accessories.
2. Scrape or wipe loose debris and grease from the oven bottom.
3. Pour 1 cup of tap water onto the oven bottom. Close oven door.

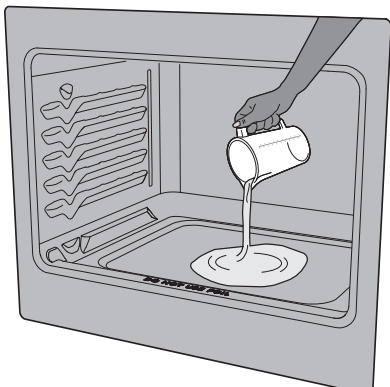

**Figure 8: Add 1 cups of tap water**

4. Touch **Oven Modes**, scroll to and touch **Steam Clean**.
5. Touch **START**.
6. The time the Steam Clean cycle will end is shown in the display. Do not open the door during this time. If door is open while in Steam Clean (d-O) will appear in the display.
7. When the steam clean cycle is complete an alert will sound and the Off message will show in the display. Press off to return to the clock.

8. Take care opening the door when the steam clean is finished. Stand to the side of the oven out of the way of escaping vapor.
9. Wipe oven cavity and bottom. Do not clean oven door gasket. Avoid leaning or resting on the oven door glass while cleaning cavity.



**Figure 9: Clean around the oven door gasket**

#### Notes:

- Opening the oven door during the steam clean cycle prevents the water from reaching the temperature needed to clean.
- For best results, clean oven immediately after the cycle is complete. Steam clean works best for soils on the oven bottom.
- A non-abrasive scouring pad, stainless steel sponge, plastic scraper, or eraser style cleaning pad (without cleaner) can be used for difficult soils. Moisten pads with water before use.
- Place a paper towel or cloth in front of the oven to capture any water that may spill while wiping out.
- Do not leave the residual water in the oven for any length of time.
- Some condensation or water vapor may appear close to the oven vent and the oven door glass. This is normal. The oven gasket may become damp; do not wipe dry.
- Local water sources often contain minerals (hard water). If hard water deposits occur, wipe cavity with a 50/50 solution of water and vinegar or 50/50 solution of lemon juice and water.
- Steam clean cannot be programmed with a delayed start time.
- If Steam Clean results are not satisfactory, run a Self Clean. See "Self Clean" on page 38.

# 42 SETTING OVEN CONTROLS

## Cooking with Food Probe

Use the probe feature for best results when cooking foods such as roasts, hams, or poultry.

The Food Probe works with the following oven modes: Bake, Convection Bake, Air Fry, Convection Roast, Steam Roast, and Turkey.

The probe feature, when set correctly, will signal an alert when the internal food temperature reaches the desired set target temperature. The probe settings for how the oven behaves should be set first in the oven menu.

When active, the probe displays the internal food temperature which is visible in the display during the cooking process. This eliminates any guesswork or the need to open the oven door to check the thermometer.

For meats like poultry and roasts, using a probe to check internal temperature is the safest method to ensure properly cooked food.

**To set Food Probe:** Touch **Oven Modes**, scroll to **Food Probe** and follow directions on the display.



## CAUTION

Do not use kitchen utensils to pull on the probe cable or handles. Always insert and remove the probe using the provided handles, as shown in and always use a pot holder to protect hands from possible burns.

## Proper placement of probe in food.

Insert the probe so that the probe tip rests inside the center of the thickest part of meat or food. For best results, do not allow the probe temperature sensor to contact bone, fat, gristle, or the cookware.

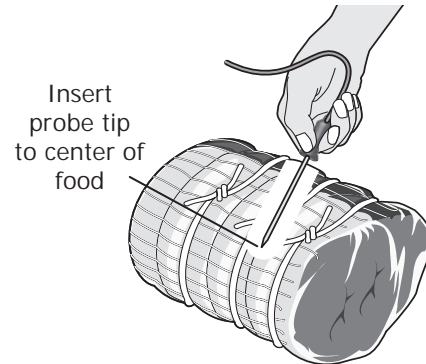

- For bone-in ham or lamb, insert the probe into the center of lowest large muscle or joint.
- For meat loaf or casseroles, insert the probe into center of food.
- When cooking fish, insert meat probe just above the gill.
- For whole poultry or turkey, fully insert the probe sensor into the thickest part of the breast.

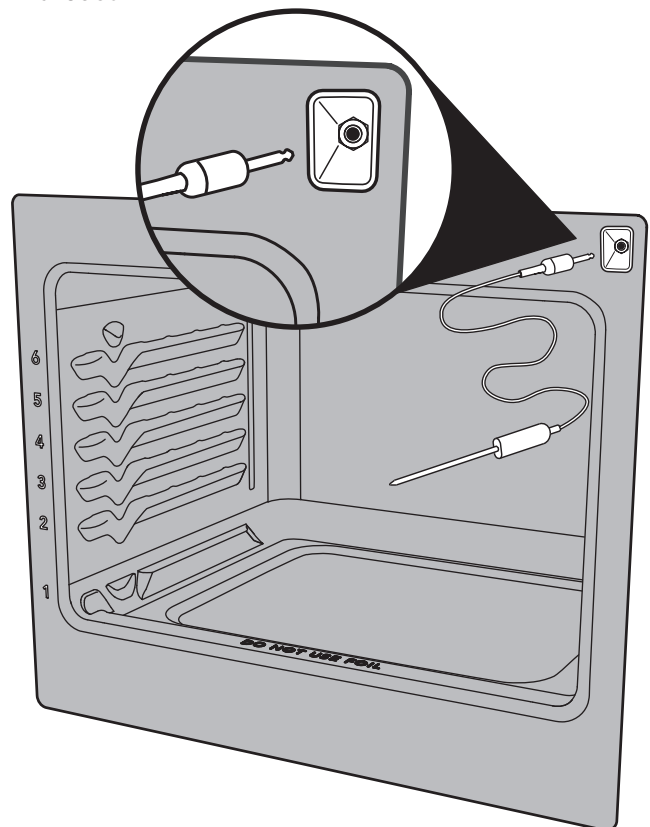

## Using the Food Probe for Turkey

1. Select **Oven Modes** and scroll to **Food Probe**.
2. The display will remind you to insert the probe into the turkey and place in oven on rack position 1.
3. Display reminds you to connect the food probe to the receptacle before setting oven mode:
4. Touch **NEXT**.
5. Touch **Turkey** in Oven Modes.
6. Set target food temperature after pressing **NEXT**.
7. Set oven temperature and press **START**.
8. When the target temperature of the turkey (internal temperature) is reached, the oven will turn off if set for cooking to stop in the Oven Menu settings.

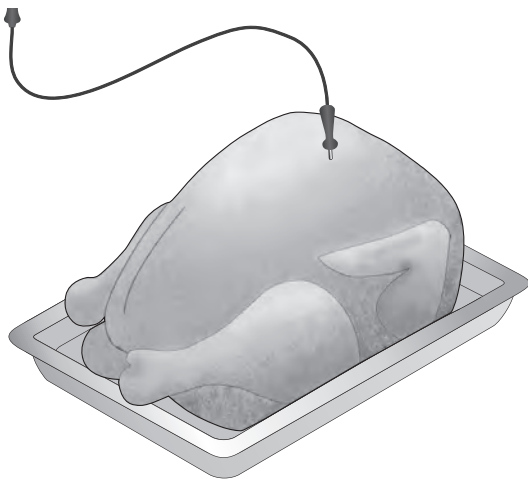

**Table 7: USDA recommended minimum internal cooking temperatures**

Food Type	Internal Temp.
Ground meat and meat mixtures	
Beef, Pork, Veal, Lamb	160°F (71°C)
Turkey, Chicken	165°F (74°C)
Fresh beef, veal, lamb	
Medium rare +	145°F (63°C)
Medium	160°F (71°C)
Well Done	170°F (77°C)
Chicken and Turkey, whole	165°F (74°C)
Poultry Breasts, Roasts	165°F (74°C)
Poultry Thighs, Wings	165°F (74°C)
Stuffing (cooked alone or in bird)	165°F (74°C)
Ham Fresh (raw)	160°F (71°C)
Ham Pre-cooked (to reheat)	140°F (60°C)
Eggs dishes	160°F (71°C)
Leftovers and Casseroles	165°F (74°C)

The U.S. Department of Agriculture states, "Rare fresh beef is popular, but you should know that cooking it to only 140°F (60°C) means some food poisoning organisms may survive." (Source: Safe Food Book, Your Kitchen Guide, USDA) Visit the USDA Food Safety and Inspection website at [www.fsis.usda.gov](http://www.fsis.usda.gov)

### ➔ NOTE

During cooking, the internal food temperature will display in the center of the screen. The oven temperature will be displayed at the bottom of the screen beside the cancel key. To assure accuracy, do not remove the probe from the food or receptacle until the desired internal temperature is reached.

If the probe is removed from the receptacle only, the probe feature will cancel and the oven will turn off. If the probe is removed from the food only, the probe feature will remain active and may eventually generate a probe too hot message.

To change the target (internal food) temperature or the set oven temperature touch the one you want to change and use the **+** or **-** to adjust the temperature.

### ➔ IMPORTANT

Do not store the probe inside the oven. Use only the original probe provided. Connecting any other probe or device could result in damage to the oven control, electronics, and the receptacle.

Before starting self clean, double check that the probe is removed from the oven interior. Defrost frozen foods completely before inserting the probe.

# 44 SETTING OVEN CONTROLS

## Setting the Sabbath Feature for the Jewish Sabbath and Holidays (some models)



For further assistance, guidelines for proper usage, and a complete list of models with the Sabbath feature, please visit the web at [www.star-k.org](http://www.star-k.org).

This appliance provides special settings for use when observing the Jewish Sabbath/Holidays. Sabbath mode disables all audible tones or visual display changes on the oven control. Bake is the only cooking feature available while in the Sabbath mode. Most oven controls are locked during Sabbath mode.

To start Sabbath Mode, first select Sabbath from the settings menu. Next, select Delay (if desired), Bake temperature, and cook time (if desired) and set. Cooking will begin after any specified delay.

If cook time was set, once the time has elapsed, the cooking will end and the display will show Idle to indicate that the cook time has ended.

**Important:** The Sabbath mode will override the factory preset 12 hour energy saving mode, and the appliance will stay on until the cooking features are canceled. If cooking is canceled when the appliance is in the Sabbath mode, no audible or visual indicators will be available to verify the cancellation.

If the oven interior lights are needed, be sure to activate them prior to setting the Sabbath mode. Once the oven light is turned on and the Sabbath mode is active, the oven light will remain on until the Sabbath mode is turned off and the oven lights are turned off. The oven door will not activate the interior oven lights when the oven door is opened or closed.

It is recommended that any oven temperature modification made within an active Sabbath mode press the + or - key.

The temperature will increase or decrease with each press by 5°F or 1°C and the change will be accepted automatically.

## WARNING

Food poisoning hazard. Do not let food sit for more than one hour before or after cooking. Doing so can result in food poisoning or sickness. Foods that can easily spoil such as milk, eggs, fish, meat or poultry, should be chilled in the refrigerator first. Even when chilled, they should not stand in the oven for more than 1 hour before cooking begins, and should be removed promptly when finished cooking.

### Important:

- Do not attempt to activate any other oven function except Bake while the Sabbath feature is active. When the Sabbath feature is active, only the + and - keys and OFF will function. ALL OTHER KEYS should not be used once the Sabbath feature is active.
- You may change the oven temperature once baking has started. Use the + and - keys to raise or lower the oven temperature. Each press of an arrow key will raise or lower the temperature by 5°F (1°C).
- Remember that the oven control will no longer provide audible tones or display any further changes when the Sabbath feature is active.
- The oven will shut-off automatically after completing a bake time and therefore may only be used once during the Sabbath/Jewish Holidays.

**SETTING SABBATH MODE:**

Sabbath Mode is set using the **Menu Options**.

1. Touch the **Menu Options** bars.
2. Scroll to **Sabbath Mode**.
3. Touch **Sabbath Mode** and follow all instructions on screen.



To exit Sabbath Mode, press and hold **EXIT** for three seconds.

# 46 CARE AND CLEANING

Remove spills and any heavy soiling as soon as possible. Regular cleaning will reduce the difficulty of major cleaning later.

## CAUTION

Before cleaning any part of the appliance, be sure all controls are turned off and the appliance is cool.

If ammonia or appliance cleaners are used, they must be removed and the appliance must be thoroughly rinsed before operating. Follow manufacturer's instructions and provide adequate ventilation.

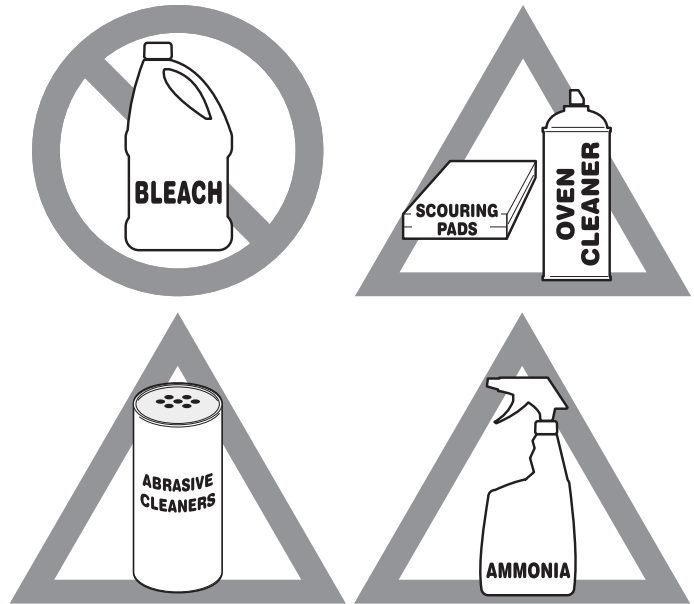
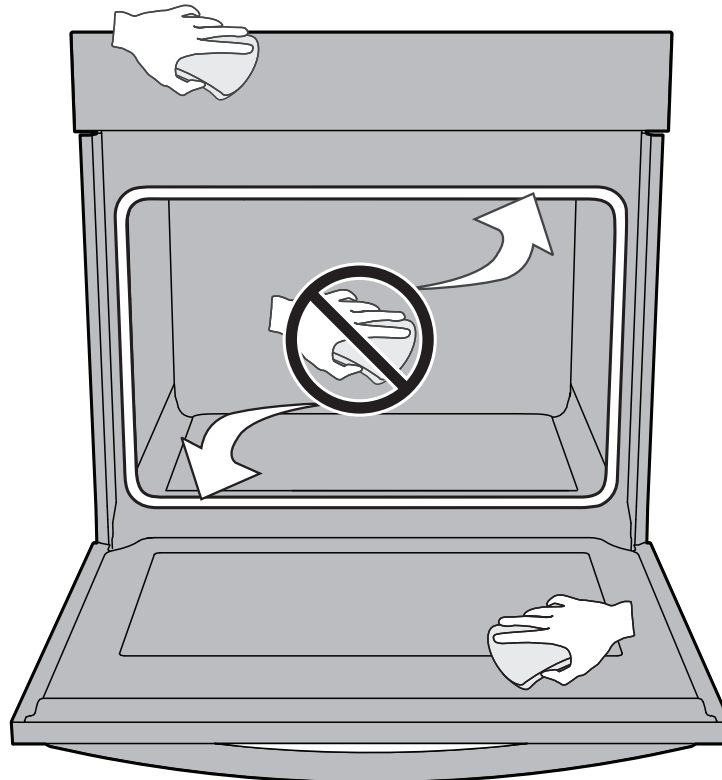

Figure 10: Use cleaners with caution

Surface or Area	Cleaning Recommendation
Aluminum and vinyl	Using a soft cloth, clean with mild dish detergent and water. Rinse with clean water, dry and polish with a soft, clean cloth.
Painted body parts Painted decorative trims	Using a soft cloth, clean with mild dish detergent and water or a 50/50 solution of vinegar and water. Rinse with clean water, dry and polish with a soft, clean cloth. Glass cleaners may be used, but do not apply directly to surface; spray onto cloth and wipe.
Touch display	Using a soft cloth, clean with mild dish detergent and water or a 50/50 solution of vinegar and water. Do not spray liquids directly on the display area. Do not use large amounts of water on the display - excess water may cause damage to the appliance. Do not use other liquid cleaners, abrasive cleaners, scouring pads, or paper towels - they may damage the finish.
Control panel	Using a soft cloth, clean with mild dish detergent and water or a 50/50 solution of vinegar and water. Do not spray liquids directly on the oven control and display area. Do not use large amounts of water on the control panel - excess water on the control area may cause damage to the appliance. Do not use other liquid cleaners, abrasive cleaners, scouring pads, or paper towels - they will damage the finish.
Control knobs	Using a soft cloth, clean with mild dish detergent and water or a 50/50 solution of vinegar and water. To remove control knobs: turn to the OFF position, grasp firmly, and pull off the shaft. To replace knobs after cleaning, line up the OFF markings and push the knobs into place.
Stainless Steel	Using a soft cloth, clean with mild dish detergent and water or a 50/50 solution of vinegar and water. Rinse with clean water, dry with a soft clean cloth. Do not use cleaners containing abrasives, chlorides, chlorine, or ammonia.
Coated Stainless Steel	Using a soft cloth, clean with mild dish detergent and water or a 50/50 solution of vinegar and water. Rinse with clean water, dry with a soft clean cloth. Do not use appliance cleaner, stainless steel cleaner, or cleaner containing abrasives, chlorides, chlorine, or ammonia. These cleaners may damage the finish.

Surface or Area	Cleaning Recommendation
Porcelain-enameled broiler pan and insert Porcelain door liner Porcelain body parts	Rinse with clean water and a damp cloth. Scrub gently with a soapy, non-abrasive scouring pad to remove most spots. Rinse with a 50/50 solution of clean water and ammonia. If necessary, cover difficult spots with an ammonia-soaked paper towel for 30 to 40 minutes. Rinse and wipe dry with a clean cloth. Remove all cleaners or future heating could damage the porcelain. Do not allow food spills with a high sugar or acid content (milk, tomatoes, sauerkraut, fruit juices or pie filling) to remain on porcelain surfaces. These spills may cause a dull spot even after cleaning.
Self-cleaning oven interior	Before setting a self-clean cycle, clean soils from the oven frame, areas outside the oven door gasket, and the small area at the front center of the oven bottom. See "Self Clean" on page 39.
Oven door	Use mild dish detergent and water or a 50/50 solution of vinegar and water to clean the top, sides, and front of the oven door. Rinse well. Glass cleaner may be used on the outside glass of the door. Ceramic smoothtop cleaner or polish may be used on the interior door glass. Do not immerse the door in water. Do not spray or allow water or cleaners to enter the door vents. Do not use oven cleaners, cleaning powders, or any harsh abrasive cleaning materials on the outside of the oven door.  Do not clean the oven door gasket. The oven door gasket is made of a woven material which is essential for a good seal. Do not rub, damage, or remove this gasket.



**Figure 11: Do not clean oven door gasket**

# 48 CARE AND CLEANING

## General Cleaning

Refer to the table at the beginning of this chapter for more information about cleaning specific parts of the oven.

### Follow these cleaning precautions:

- Allow the oven to cool before cleaning.
- Wear rubber gloves when cleaning the appliance manually.

Remove soils using hot, soapy water. Do not allow food spills with a high sugar or acid content (such as milk, tomatoes, sauerkraut, fruit juices or pie filling) to remain on the surface as they may cause a dull spot even after cleaning. Remove spillovers and heavy soiling as soon as possible. Regular cleaning will reduce the effort required for major cleaning later.



### CAUTION

Before manually cleaning any part of the oven, be sure all controls are turned off and the oven is cool. The oven may be hot and can cause burns.

Remove all racks and accessories from the oven before cleaning.

Ammonia must be rinsed before operating the oven. Provide adequate ventilation.

## Cleaning Porcelain Enamel Oven

The oven interior is porcelain on steel, it is safe to clean using oven cleaners.

### To remove heavy soil:

1. Allow a dish of ammonia to sit in the oven overnight or for several hours with the oven door closed. Clean softened dirt spots using hot, soapy water. Rinse well with water and a clean cloth.
2. If soil remains, use a nonabrasive scouring pad or a nonabrasive cleaner. If necessary, use an oven cleaner following manufacturer's instructions. Do not mix ammonia with other cleaners.
3. Clean any soil from the oven frame, the door liner outside the oven door gasket and the small area at the front center of the oven bottom. Clean with hot, soapy water. Rinse well using clean water and a cloth.

### Broiler Pan Cleaning Tips

To prevent grease from baking on, remove the broiler pan from the oven as soon as cooking is completed. Use oven mitts because the broiler pan is extremely hot. Pour off grease. Soak the pan in hot, soapy water.

Clean the broiler pan as soon as possible after each use. If necessary, use soap-filled steel wool pads. Heavy scouring may scratch the grid.

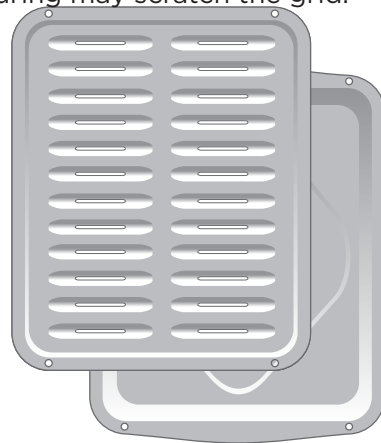

Figure 12: Broiler pan with insert



## Aluminum Foil, Aluminum Utensils, and Oven Liners

### **! WARNING**

Never cover any slots, holes, or passages in the oven bottom or cover an entire oven rack with materials such as aluminum foil. Doing so blocks air flow through the oven and may cause carbon monoxide poisoning. Aluminum foil linings may trap heat, causing a fire hazard.

- Protective liners—Do not use aluminum foil to line the oven bottom. The high heat of the oven can melt these materials to the oven cavity and ruin the oven. These types of materials can also reduce the effectiveness of the air circulation in the oven and produce poor baking results. Only use aluminum foil as recommended in this manual. Improper installation of these liners may result in risk of electric shock or fire.
- Aluminum utensils - The melting point of aluminum is much lower than that of other metals. Care must be taken when aluminum pots or pans are used.
- Oven racks - Do not use aluminum foil to cover the oven racks. Using a liner in the oven restricts the heat and air flow needed to obtain the best possible cooking results for any oven.

## Replacing the Oven Light

### **! CAUTION**

Be sure the oven is unplugged and all parts are cool before replacing the oven light.

The interior oven light is located at the rear of the oven cavity and is covered by a glass shield. The glass shield must be in place whenever the oven is in use.

### To replace the oven interior light bulb:

1. Turn electrical power off at the main source or unplug the appliance.
2. Remove interior oven light shield by turning a quarter turn counter-clockwise.
3. Replace bulb with a new T-4 type Halogen 25 watt appliance bulb.

### **➔ NOTE**

Wear a cotton glove or use a paper towel when installing a new bulb. Do not touch the new bulb with your fingers when replacing. This will shorten the life of the bulb.

4. Replace glass oven light shield by rotating clockwise.
5. Turn power back on again at the main source (or plug the appliance back in).
6. Be sure to reset the time of day on the clock.

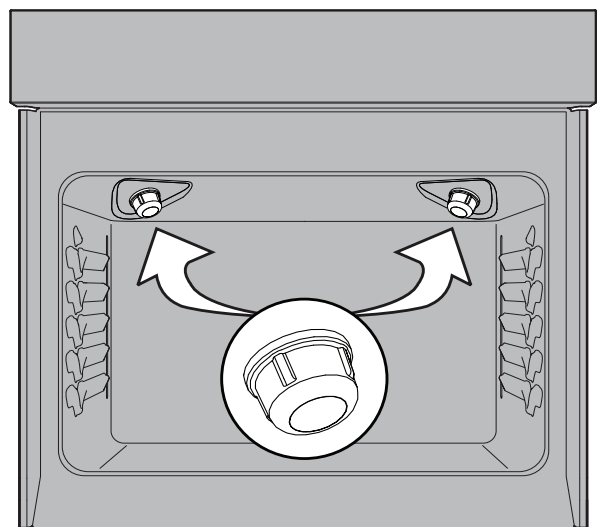

**Figure 13: Wall oven Halogen light**

# 50 CARE AND CLEANING

## Caring for Your Glide Racks

**Caution:** Handle oven racks only when they are cool. After cooking or after the fresh-clean cycle, racks will be very hot and can cause burns.

### Important Notes:

- Remove all oven racks, including ladder racks, before starting a clean cycle.
- Do not use cooking oil, cooking spray, or other oil-based lubrication products on the glide rack extension tracks. Use only the graphite lubrication in this area. To order graphite lubrication, contact your installer, servicer or dealer.
- It is important that the parts of the rack that contact the oven sides always have a light coating of vegetable oil. Apply a thin layer of vegetable oil to the sides of the rack after every fresh-clean cycle and when the rack becomes difficult to reposition in the oven.

### To lubricate the glide rack:

1. Remove the rack from the oven and place the rack on a large flat surface covered with newspaper or scrap cloth. Fully extend the rack.
2. Wipe away debris and crumbs from the glide track using a cloth or sponge.

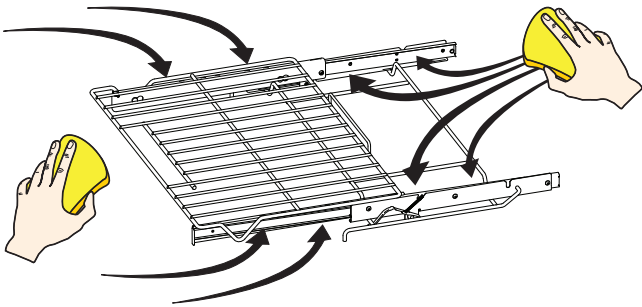

3. Shake graphite lubrication very well before applying. Apply to loading guides, and rotation pin. Repeat on both sides of the glide rack.

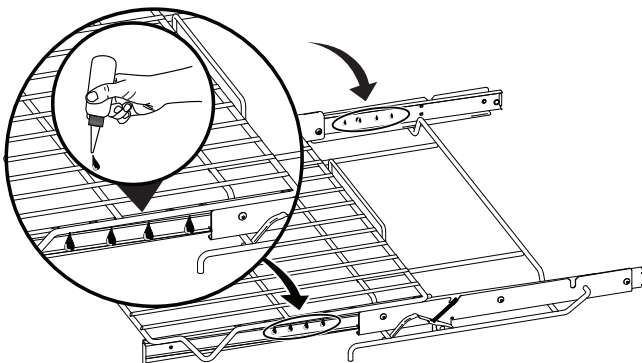

4. Extend and return the glide rack several times along the tracks to distribute the lubrication.

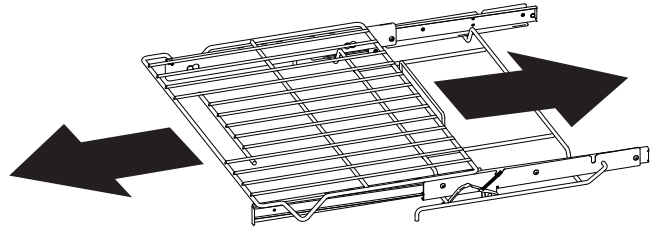

5. Turn the rack upside down and apply graphite lubrication to the insides of the loading guides.

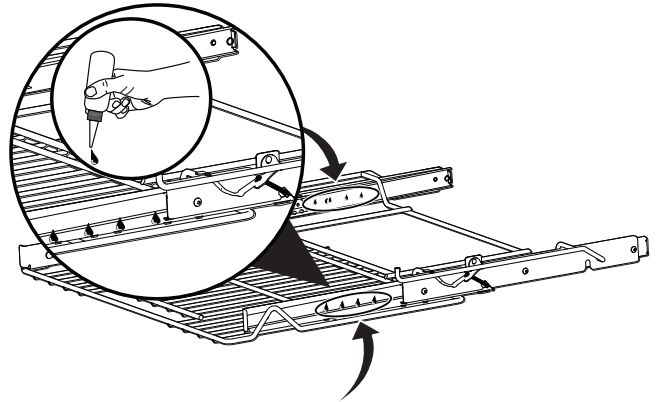

6. Extend and return the glide rack several times along the tracks to distribute the lubrication.
7. Apply a thin layer of cooking oil to the bottom of the "V" and the glide channels. Keeping the frame sides lightly lubricated allows the entire rack to slide easily when changing rack positions.
8. Replace rack in oven right-side up.

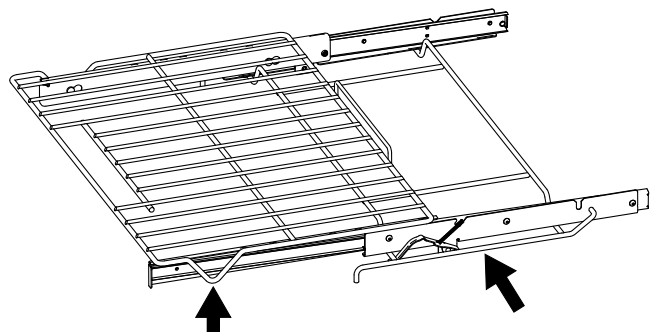

## Removing and Replacing the Oven Door

### CAUTION

The door is heavy. For safe, temporary storage, lay the door flat with the inside of the door facing down.

### IMPORTANT

Special door care instructions - For safe, temporary storage, lay the door flat with the inside of the door facing down.

Most oven doors contain glass that can break. Do not hit the glass with pots, pans, or any other object. Scratching, hitting, jarring, or stressing the glass may weaken its structure, causing an increased risk of breakage at a later time. Do not close the oven door until all of the oven racks are fully in place.

#### To remove the oven door:

1. Open oven door completely, horizontal with floor (Figure 14).
2. Pull up the lock located on each hinge support toward front of the oven until the lock stops. You may have to apply a little upward pressure on the lock to pull it up (Figure 15).
3. Grasp the door by the sides, and close the door until the door frame makes contact with the unlocked hinges (Figure 16).
4. Pull the bottom of the door toward you while rotating the top of the door toward the appliance to completely disengage the hinge levers (Figure 17).

#### To replace the oven door:

1. Firmly grasp both sides of oven door along the door sides. Do not use the oven door handle (Figure 17).
2. Hold the oven door at the same angle as the removal position (Figure 16) Carefully insert the hinge levers into the oven frame until you feel the hinge levers are seated into the hinge notches. The hinge arms must be fully seated into the hinge notches before the oven door can be fully opened.
3. Fully open the oven door, horizontal with floor (Figure 14).
4. Push the door hinge locks up toward and into the oven frame on both left and right oven door hinges to the locked position (Figure 15).
5. Close the oven door.

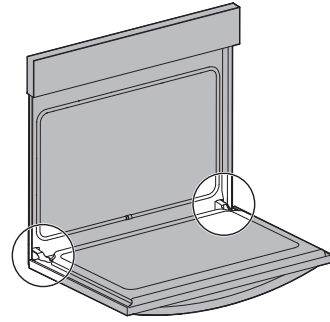

Figure 14: Door hinge location

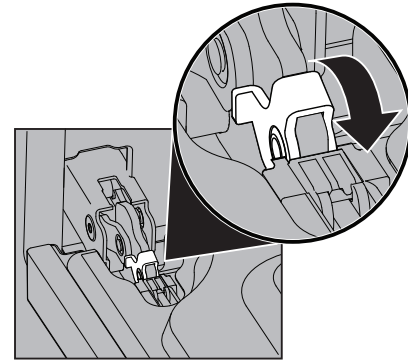

Figure 15: Door hinge lock

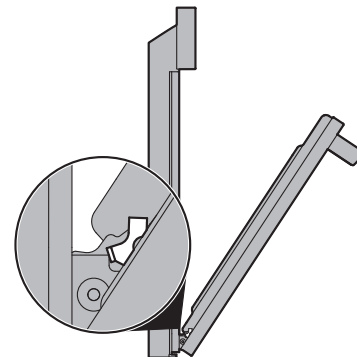

Figure 16: Removal position

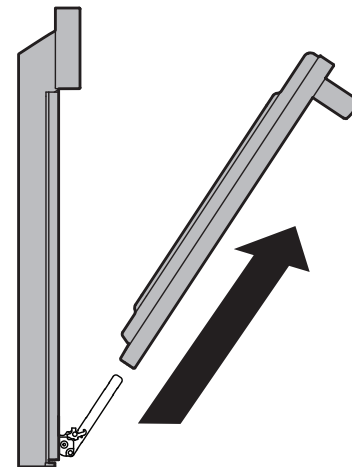







Figure 17: Remove door

### Oven Baking

For best cooking results, preheat the oven before baking cookies, breads, cakes, pies, pastries, etc. There is no need to preheat the oven for roasting meat or baking casseroles. The cooking times and temperatures needed to bake a product may vary slightly from your previously owned appliance.

Baking Problems and Solutions Baking Problems		
Baking Problems	Causes	Corrections
Cookies and biscuits burn on the bottom. 	Cookies and biscuits put into oven before oven is preheated.	Allow oven to preheat to desired temperature before placing food in oven. Choose pan sizes that will permit at least 2" of air space.
Cakes too dark on top or bottom 	Cakes put in oven before oven is preheated. Rack position too high or too low. Oven too hot.	Allow oven to preheat to the selected temperature before placing food in the oven. Use proper rack position for baking needs. Set oven temperature 25°F (13°C) lower than recommended.
Cakes not done in center 	Oven too hot. Incorrect pan size. Pan not centered in oven. Glass cookware slow heat conductor.	Set oven temperature 25°F (13°C) lower than recommended. Use pan size suggested in recipe. Use proper rack position and place pan so there are at least 2" (5.1 cm) of space on all sides of pan. Reduce temperature and increase cook time or use shiny bakeware.
Cakes not level. 	Oven not level. Pan too close to oven wall or rack overcrowded. Pan warped. Oven light left on while baking.	Place a marked glass measuring cup filled with water on the center of the oven rack. If the water level is uneven, refer to the installation instructions for leveling the oven. Use proper rack position and place pan so there are at least 2" (5.1 cm) of space on all sides of pan. Do not use pans that are dented or warped. Do not leave the oven light on while baking.
Foods not done when cooking time is over. 	Oven too cool. Oven overcrowded. Oven door opened too frequently.	Set oven temperature 25°F (13°C) higher than suggested and bake for the recommended time. Be sure to remove all pans from the oven except the ones to be used for baking. Open oven door only after the shortest recommended baking time.

## BEFORE YOU CALL

Let us help you troubleshoot your concern! This section will help you with common issues. If you need us, visit our website, chat with an agent, or call us. We may be able to help you avoid a service visit. If you do need service, we can get that started for you!

1-800-374-4432 (United States)

**Frigidaire.com**

1-800-265-8352 (Canada)

**Frigidaire.ca**

Problem	Cause / Solution
Entire appliance does not operate	Appliance not connected. Make sure power cord is plugged properly into outlet. Check your fuse box or breaker box to make sure the circuit is active.  Electrical power outage. Check house lights to be sure. Call your local electric company for service outage information.

Oven Problems	
Problem	Cause / Solution
Poor baking results.	Many factors affect baking results. Use proper oven rack position. Center food in the oven and space pans to allow air to circulate. Preheat the oven to the set temperature before placing food in the oven. Try adjusting the recipe's recommended temperature or baking time. See "Oven Temperature Calibration" on page 19 if you feel the oven is too hot or too cool.
Flames inside oven or smoking from oven vent	Excessive spills in oven. Grease or food spilled onto the oven bottom or oven cavity. Wipe up excessive spills before starting the oven. If flames or excessive smoke are present when using broil, see "Setting Broil" on page 35.
Oven smokes excessively when broiling.	Incorrect setting. Follow the "Setting Broil" on page 35.  Meat too close to the broil element or burner. Reposition the broil pan to provide proper clearance between the meat and broil element or burner. Remove excess fat from meat. Cut remaining fatty edges to prevent curling, but do not cut into lean.  Grease build up on oven surfaces. Regular cleaning is necessary when broiling frequently. Grease or food splatters will cause excessive smoking.
Convection fan does not rotate.	Oven door is open. The convection fan will turn off if the oven door is opened when convection is active. Close the oven door.

Self-Clean Problems	
Problem	Cause / Solution
Self clean does not work.	Oven control not set properly. See "Self Clean" on page 41.
Oven racks discolored or do not slide easily.	Oven racks left in oven cavity during self clean. Remove oven racks from oven cavity before starting a self-clean cycle. Clean by using a mild abrasive cleaner following manufacturer's instructions. Rinse with clean water, dry, and replace in oven.
Soil not completely removed after self clean.	<p>Self clean was interrupted. Review instructions on "Self Clean" on page 41.</p> <p>Excessive spills on oven bottom. Remove excessive spills before starting self clean.</p> <p>Failure to clean soil from the oven frame, the door liner outside the oven door gasket, and the small area at the front center of the oven bottom. These areas are not in the self-cleaning area, but get hot enough to burn on residue. Clean these areas before starting the self-cleaning cycle. Burned-on residue can be cleaned with a stiff nylon brush and water or a nylon scrubber. Be careful not to damage the oven gasket.</p>

Other Problems	
Problem	Cause / Solution
Appliance is not level.	<p>Poor installation. Place the oven rack in the center of the oven. Place a level on the oven rack. Adjust the leveling legs at the base of the appliance until the rack is level.</p> <p>Kitchen cabinet alignment may make range appear not level. Be sure cabinets are square and have sufficient room for appliance clearance.</p>
Cannot move appliance easily. Appliance must be accessible for service.	Cabinets not square or are built in too tightly. Contact the builder or installer to make the appliance accessible.
Oven light does not work.	Be sure the oven light is secure in the socket. See "Replacing the Oven Light" on page 63.

Your appliance is covered by a one year limited warranty. For one year from your original date of purchase, Electrolux will pay all costs for repairing or replacing any parts of this appliance that prove to be defective in materials or workmanship when such appliance is installed, used and maintained in accordance with the provided instructions.

## Exclusions

This warranty does not cover the following:

Products with original serial numbers that have been removed, altered or cannot be readily determined.

Product that has been transferred from its original owner to another party or removed outside the USA or Canada.

Rust on the interior or exterior of the unit.

Products purchased "as-is" are not covered by this warranty.

Food loss due to any refrigerator or freezer failures.

Products used in a commercial setting.

Service calls which do not involve malfunction or defects in materials or workmanship, or for appliances not in ordinary household use or used other than in accordance with the provided instructions.

Service calls to correct the installation of your appliance or to instruct you how to use your appliance.

Expenses for making the appliance accessible for servicing, such as removal of trim, cupboards, shelves, etc., which are not a part of the appliance when it is shipped from the factory.

Service calls to repair or replace appliance light bulbs, air filters, water filters, other consumables, or knobs, handles, or other cosmetic parts.

Surcharges including, but not limited to, any after hour, weekend, or holiday service calls, tolls, ferry trip charges, or mileage expense for service calls to remote areas, including the state of Alaska.

Damages to the finish of appliance or home incurred during installation, including but not limited to floors, cabinets, walls, etc.

Damages caused by: services performed by unauthorized service companies; use of parts other than genuine Electrolux parts or parts obtained from persons other than authorized service companies; or external causes such as abuse, misuse, inadequate power supply, accidents, fires, or acts of God.

## DISCLAIMER OF IMPLIED WARRANTIES; LIMITATION OF REMEDIES

CUSTOMER'S SOLE AND EXCLUSIVE REMEDY UNDER THIS LIMITED WARRANTY SHALL BE PRODUCT REPAIR OR REPLACEMENT AS PROVIDED HEREIN. CLAIMS BASED ON IMPLIED WARRANTIES, INCLUDING WARRANTIES OF MERCHANTABILITY OR FITNESS FOR A PARTICULAR PURPOSE, ARE LIMITED TO ONE YEAR OR THE SHORTEST PERIOD ALLOWED BY LAW, BUT NOT LESS THAN ONE YEAR. ELECTROLUX SHALL NOT BE LIABLE FOR CONSEQUENTIAL OR INCIDENTAL DAMAGES SUCH AS PROPERTY DAMAGE AND INCIDENTAL EXPENSES RESULTING FROM ANY BREACH OF THIS WRITTEN LIMITED WARRANTY OR ANY IMPLIED WARRANTY. SOME STATES AND PROVINCES DO NOT ALLOW THE EXCLUSION OR LIMITATION OF INCIDENTAL OR CONSEQUENTIAL DAMAGES, OR LIMITATIONS ON THE DURATION OF IMPLIED WARRANTIES, SO THESE LIMITATIONS OR EXCLUSIONS MAY NOT APPLY TO YOU. THIS WRITTEN WARRANTY GIVES YOU SPECIFIC LEGAL RIGHTS. YOU MAY ALSO HAVE OTHER RIGHTS THAT VARY FROM STATE TO STATE.

## If You Need Service

Keep your receipt, delivery slip, or some other appropriate payment record to establish the warranty period should service be required. If service is performed, it is in your best interest to obtain and keep all receipts. Service under this warranty must be obtained by contacting Electrolux at the addresses or phone numbers below.

This warranty only applies in the USA and Canada. In the USA, your appliance is warranted by Electrolux Major Appliances North America, a division of Electrolux Home Products, Inc. In Canada, your appliance is warranted by Electrolux Canada Corp. Electrolux authorizes no person to change or add to any obligations under this warranty. Obligations for service and parts under this warranty must be performed by Electrolux or an authorized service company. Product features or specifications as described or illustrated are subject to change without notice.

## USA

**1-877-435-3827**

Electrolux Major Appliances NA  
10200 David Taylor Drive  
Charlotte, NC 28262  
ElectroluxAppliances.com



# Electrolux

## Canada

**1.800.265.8352**

Electrolux Canada Corp.  
5855 Terry Fox Way  
Mississauga, Ontario, Canada  
L5V 3E4  
ElectroluxAppliances.ca

# FRIGIDAIRE®

welcome *home*

A22383501 A (EN) July 2021

Our home is your home. Visit us if you need help with any of these things:



owner support



accessories



service



registration

(See your registration card for more information.)

Frigidaire.com  
1-800-374-4432

Frigidaire.ca  
1-800-265-8352



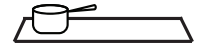

# INDUCTION COOKTOP

## *use & care*

Introduction . . . . .	2	Care and Cleaning . . . . .	20
Important Safety Instructions . . . . .	3	Before You Call . . . . .	23
Before Setting Surface Controls . . . . .	9	Warranty . . . . .	24
Setting Surface Controls . . . . .	15		

# 2

## INTRODUCTION

Welcome to our *family*

Thank you for bringing Frigidaire into your home! We see your purchase as the beginning of a long relationship together.

This manual is your resource for the use and care of your product. Please read it before using your appliance. Keep it handy for quick reference. If something doesn't seem right, the troubleshooting section will help you with common issues.

FAQs, helpful tips and videos, cleaning products, and kitchen and home accessories are available at [www.frigidaire.com](http://www.frigidaire.com).

We are here for you! Visit our website, chat with an agent, or call us if you need help. We may be able to help you avoid a service visit. If you do need service, we can get that started for you.

Let's make it official! Be sure to register your product.

Keep your product info here so it's easy to find.

Model Number: \_\_\_\_\_

Serial Number: \_\_\_\_\_

Purchase Date: \_\_\_\_\_

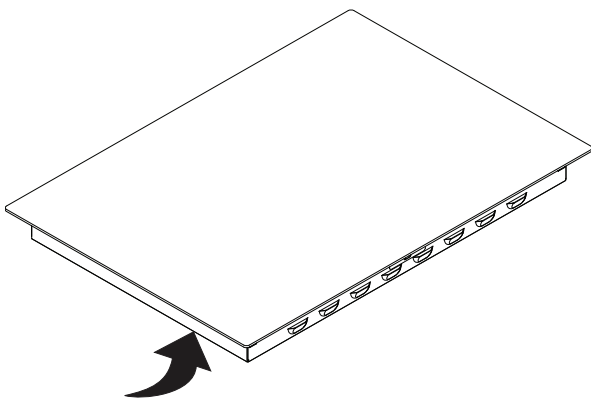

Serial Number Location



### Installation Checklist

- Read all the safety instructions in the front of your Use & Care Manual.
- Remove all packaging materials from your appliance before cooking.
- Confirm that the electrical power to the appliance is turned on.
- Test all cooking zones to make sure they are working properly (page ref).
- Remember to complete your product registration!

Read all instructions before using this appliance.

This manual contains important safety symbols and instructions. Please pay attention to these symbols and follow all instructions given.

Do not attempt to install or operate your appliance until you have read the safety precautions in this manual. Safety items throughout this manual are labeled with a WARNING or CAUTION statement based on the risk type.

Warnings and important instructions appearing in this guide are not meant to cover all possible conditions and situations that may occur. Common sense, caution, and care must be exercised with installing, maintaining, or operating your appliance.

## DEFINITIONS



This is the safety alert symbol. It is used to alert of potential personal injury hazards. Obey all safety messages that follow this symbol to avoid possible injury or death.



### WARNING

Indicates a potentially hazardous situation which, if not avoided, may result in death or serious injury.



### CAUTION

Indicates a potentially hazardous situation which, if not avoided, may result in minor or moderate injury.



### IMPORTANT

Indicates installation, operation or maintenance information which is important but not hazard-related.



### NOTE

Indicates a short, informal reference - something written down to assist the memory or for future reference.

## IMPORTANT INSTRUCTIONS FOR UNPACKING AND INSTALLATION



### IMPORTANT

Read and follow the below instructions and precautions for unpacking, installing, and servicing your appliance.

Remove all tape and packaging before using the appliance. Destroy the carton and plastic bags after unpacking the appliance. Never allow children to play with packaging material. Do not remove the wiring label and other literature attached to the appliance. Do not remove model/serial number plate.

Cold temperatures can damage the electronic control. When using this appliance for the first time, or when the appliance has not been used for an extended period of time, be sure the appliance has been in temperatures above 32°F (0°C) for at least 3 hours before turning on the power to the appliance.

Never modify or alter the construction of the appliance by removing the leveling legs, panels, wire covers, anti-tip brackets/screws, or any other part of the appliance.

Be sure to have an appropriate foam-type fire extinguisher available, visible, and easily accessible located near the appliance.

# 4

## IMPORTANT SAFETY INSTRUCTIONS

### GROUNDING INSTRUCTIONS

#### WARNING

- Avoid fire hazard or electrical shock. Failure to follow this warning may cause serious injury, fire, or death.
- Avoid fire hazard or electrical shock. Do not use an adapter plug, use an extension cord, or remove grounding prong from the power cord. Failure to follow this warning may cause serious injury, fire, or death.

Proper Installation—Be sure your appliance is properly installed and grounded by a qualified technician. In the United States, install in accordance with the National Fuel Gas Code ANSI Z223.1/NPFA No. 54, latest edition and National Electrical Code NFPA No. 70 latest edition, and local electrical code requirements. In Canada, install in accordance with CAN/CGA B149.1 and CAN/CGA B149.2 and CSA Standard C22.1, Canadian Electrical code, Part 1-latest editions and local electrical code requirements. Install only per installation instructions provided in the literature package for this appliance.

For personal safety, this appliance must be properly grounded. For maximum safety, the power cord must be securely connected to an electrical outlet or junction box that is the correct voltage, is correctly polarized and properly grounded, and protected by a circuit breaker in accordance with local codes.

It is the personal responsibility of the consumer to have the appropriate outlet or junction box with the correct, properly grounded wall receptacle installed by a qualified electrician. It is the responsibility and obligation of the consumer to contact a qualified installer to assure that the electrical installation is adequate and is in conformance with all local codes and ordinances.

See the installation instructions packaged with this appliance for complete installation and grounding instructions.

### IMPORTANT INSTRUCTIONS FOR USING THE APPLIANCE

#### WARNING

- Storage In or On Appliance—Flammable materials should not be stored in an oven or microwave, near surface burners or elements, or in the storage or warmer drawer (if equipped). This includes paper, plastic, and cloth items, such as cookbooks, plastic ware, and towels, as well as flammable liquids. Do not store explosives, such as aerosol cans, on or near the appliance.
- Do not leave children alone - Children should not be left alone or unattended in the area where appliance is in use. They should never be allowed to sit or stand on any part of the appliance, including the storage drawer, lower broiler drawer, warmer drawer, or lower double oven.

**! WARNING**

- Do not store items of interest to children in the cabinets above the appliance or on the backguards of ranges. Children climbing on or near the appliance to reach items could be seriously injured.
- Do not allow children to climb or play around the appliance. The weight of a child on an open oven door may cause the appliance to tip, resulting in serious burns or other injury. An open drawer when hot may cause burns. Stepping, leaning, or sitting on the door or drawers of this appliance can result in serious injuries and also cause damage to the appliance.
- Never cover any slots, holes or passages in the oven bottom or cover and entire rack with materials such as aluminum foil. Doing so blocks air flow through the oven and may cause carbon monoxide poisoning. Aluminum foil linings may also trap heat, causing a fire hazard.
- Do not use oven or warmer drawer (if equipped) for storage.
- Never use your appliance as a space heater to heat or warm the room. Doing so may result in carbon monoxide poisoning and overheating of the appliance.

**! CAUTION**

- When heating fat or grease, watch it closely. Grease may catch fire if it becomes too hot.
- Do not use water or flour on grease fires. Smother fire or flame or use dry chemical or foam-type extinguisher. Cover the fire with a pan lid or use baking soda.

**! CAUTION**

- Use dry potholders. Moist or damp potholders on hot surfaces may result in burns from steam. Do not let potholders touch hot cooking areas. Do not use towels or other bulky cloths.
- Do not heat unopened food containers - Build-up of pressure may cause container to burst and result in injury.
- Wear proper apparel - Loose-fitting or hanging garments should never be worn while using the appliance. Do not let clothing or other flammable materials contact hot surfaces.
- Do not touch surface burners or elements, areas near these burners or elements, interior surfaces of the oven, or the warmer drawer (if equipped). Surface burners and elements may be hot even though they appear cool. Areas near surface burners and elements may become hot enough to cause burns. During and after use, do not touch, or let clothing or other flammable materials touch these areas until they are cool. These areas may include the cooktop, surfaces facing the cooktop, oven vent areas, oven door, and oven window.
- Do not attempt to operate the appliance during a power failure. If the power fails, always turn off the appliance. If the appliance is not turned off and the power resumes, electric surface elements may resume operation when power is restored. Once the power resumes, reset the clock and the oven function.

# 6

## IMPORTANT SAFETY INSTRUCTIONS

---

### IMPORTANT INSTRUCTIONS FOR USING YOUR INDUCTION COOKTOP

#### **WARNING**

If an oven installed underneath is performing self-clean, then the surface cooking unit must be turned off.

#### **CAUTION**

Persons with a pacemaker or similar medical device should exercise caution using or standing near an induction unit while it is in operation, as the electromagnetic field may affect the working of the pacemaker or similar medical device. It would be advisable to consult your doctor or the pacemaker or similar medical device manufacturer about your particular situation.

Know which knob or key controls each surface heating area. Place cookware with food on the cooking area before turning it on. Turn the cooking area off before removing the cookware.

Cookware handles should be turned inward and not extend over adjacent surface elements. — To reduce the risk of burns, ignition of flammable materials, and spillage due to unintentional contact with the utensil, the handle of the cookware should be positioned so that it is turned inward, and does not extend over other cooking areas.

Glazed cooking utensils — Only certain types of cookware are suitable for cooktop service and must be magnetic to work properly on the induction zones. Check the manufacturer's recommendations for cooktop use to ensure that the cookware is compatible with induction cooking.

Improper cookware may break due to sudden changes in temperature. Check the cookware manufacturer's recommendations for cooktop use.

Use proper pan size - This appliance is equipped with one or more surface units of different sizes. Select cookware with flat bottoms that match the surface unit size. Using the proper cookware on the cooking area will improve efficiency.

Never leave surface elements unattended. Boil-overs may cause smoking and greasy spills that may ignite. A pan that has boiled dry could be damaged and may damage the cooktop.

When you are flaming foods under a ventilating hood, turn on the fan.

### IMPORTANT INSTRUCTIONS FOR GLASS AND CERAMIC COOKTOPS

Do Not Clean or Operate a Broken Cooktop. If cooktop should break, cleaning solutions and spillovers may penetrate the broken cooktop and create a risk of electric shock. Contact a qualified technician immediately.

Clean cooktop glass with caution. If a wet sponge or cloth is used to wipe spills on a hot cooking area, be careful to avoid a steam burn. Some cleaners can produce harmful fumes if applied to a hot surface.

Avoid scratching the cooktop glass with sharp objects.

---

### IMPORTANT INSTRUCTIONS FOR CLEANING YOUR APPLIANCE

#### CAUTION

Before manually cleaning any part of the appliance, be sure all controls are turned off and the appliance is cool. Cleaning a hot appliance can cause burns.

Clean the appliance regularly to keep all parts free of grease that could catch fire. Do not allow grease to accumulate. Greasy deposits in the fan could catch fire.

Always follow the manufacturer's recommended directions for use of kitchen cleaners and aerosols. Be aware that excess residue from cleaners and aerosols may ignite causing damage and injury.

Clean ventilating hoods frequently - Grease should not be allowed to accumulate on hood or filter. Follow the manufacturer's instructions for cleaning vent hoods.

### IMPORTANT INSTRUCTIONS FOR SERVICE AND MAINTENANCE

Do not repair or replace any part of the appliance unless specifically recommended in the manuals. All other servicing should be done only by a qualified technician. This reduces the risk of personal injury and damage to the appliance.

Always contact your dealer, distributor, service agent, or manufacturer about problems or conditions you do not understand.

Ask your dealer to recommend a qualified technician and an authorized repair service. Know how to disconnect the power to the appliance at the circuit breaker or fuse box in case of an emergency.

Remove the oven door from any unused oven if it is to be stored or discarded.

Do not touch a hot oven light bulb with a damp cloth. Doing so could cause the bulb to break. Handle halogen lights (if equipped) with paper towels or soft gloves. Disconnect the appliance or shut off the power to the appliance before removing and replacing the bulb.

#### WARNING

California Residents: for cancer and reproductive harm information, visit [www.P65Warnings.ca.gov](http://www.P65Warnings.ca.gov)

# 8

## IMPORTANT SAFETY INSTRUCTIONS

---

Important: This appliance has been tested and found to comply with the limits for a class B digital device, pursuant to Part 18 of the FCC rules (United States) and ICES-001 (Canada). These limits are designed to provide reasonable protection against harmful interference in a residential installation. This unit uses and can radiate radio frequency energy and, if not installed and used in accordance with the instructions, may cause harmful interference to radio communications. However there is no guarantee that interference will not occur in a particular installation. If this unit does cause harmful interference to radio or television reception, which can be determined by turning the unit off and on, the user is encouraged to try to correct the interference by one or more of the following measures:

- Reorient or relocate the receiving antennae.
  - Increase distance between unit and receiver.
  - Connect the unit into an outlet or a circuit different from that to which the receiver is connected.
-



## How does induction work?

Most cooking uses radiant heat that must pass through the cookware to get food hot. Induction is a process that induces heat with an energy reaction. When each cooking zone is turned on, power goes to a coil under the cooktop. The powered coil creates an electromagnetic field. The electromagnetic field reacts with compatible materials in cookware, creating heat in the cookware itself. The power level controls the heating level, delivering precise results.

### Induction Benefits

Because heat starts in the cookware instead of the cooktop, induction offers several advantages.

**Cleaner cooking:** Because induction works by heating the cookware and not the cooktop, spills don't cook or stick to the surface.

**Cooler Cooktop:** An induction cooktop will be cooler when you remove cookware than a conventional cooktop would be. The only radiant heat produced in induction is from the cookware itself, so the kitchen stays cooler, too.

**Fast Heating:** Cookware will heat up faster than on a conventional electric cooktop. Pay close attention to avoid scorching food when starting to cook. You may need to use a lower setting for cooking food than you are used to.

**Precise Control:** The heat going into the cookware will change immediately when you change the setting of the cooking zone.

**Even Heating:** Cookware will typically heat more evenly on an induction cooktop, so you are less likely to have hot or cool spots in the cookware.

**Energy Efficiency:** Because induction creates heat directly in the pan, it uses less electricity than a conventional cooktop.

### Before Using Your Cooktop

Before using your cooktop for the first time, apply a ceramic cooktop cleaning cream (available in most hardware, grocery, and department stores) to the ceramic surface. Clean and buff with a clean paper towel. Cooktop cleaning creams leave a protective finish on the glass that will make cleaning easier when the cooktop is soiled from cooking and help prevent scratches and abrasions.



## CAUTION

Although induction cooking zones do not produce heat, **they can become hot from contact with hot cookware**. Burns may occur if a cooking zone or the surrounding area is touched before it has cooled to a safe temperature.

## Sounds

The magnetic field over the induction cooking zone may cause cookware to vibrate, creating a buzzing or humming noise. These sounds are not unusual, especially at high settings.

Cookware that is not perfectly flat on the bottom may vibrate slightly against the cooktop.

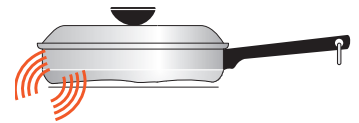

A loose handle may vibrate in its socket.

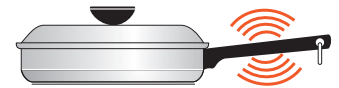

Multi-material cookware may allow small vibrations in its structure.



**Figure 1: Induction sounds**

Sounds are less likely to occur with heavier, higher quality cookware.

An induction cooktop may also produce faint clicking sounds from the electronic switches that maintain the desired cooking temperature. You may also hear a fan that cools the electronics inside the cooktop.



## NOTE

Be sure to read detailed instructions for induction cooktop cleaning in the "Care and Cleaning" section and "Before You Call" checklist section of this Use and Care Manual.

# 10 BEFORE SETTING SURFACE CONTROLS

## Using Proper Cookware

The size and type of cookware used will influence the heat setting needed for best cooking results. Be sure to follow the recommendations for using proper cookware as illustrated in Figure 2.

Check for flatness by rotating a ruler across the bottom of the cookware (see Figure 1). Cookware should have flat bottoms that make good contact with the entire surface of the heating element (see Figure 2).

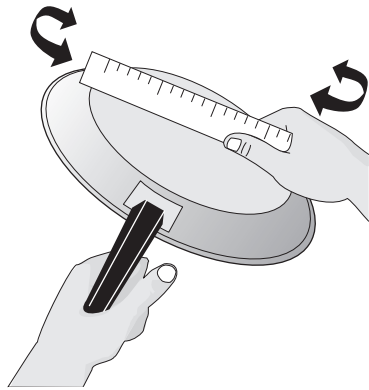

Figure 2: Testing cookware

## Cookware Material Types

Cookware material is especially important when using an induction cooktop. The cookware must contain magnetic iron or steel to work on an induction cooktop. Common materials for induction cookware include the following:

- **Stainless Steel** - Slow heat conductor. Durable, easy to clean, and resists staining. Some types of stainless steel will not work on an induction cooktop. Use the magnet test (see “Figure 4: Magnet test”) to check stainless steel cookware.
- **Cast Iron** - A slow heat conductor that retains heat very well. Cooks evenly once cooking temperature is reached.
- **Porcelain-enamel on metal** - Heating characteristics will vary depending on the base material. Porcelain-enamel on a compatible metal will work on an induction cooktop. Use the magnet test to check porcelain-enamel cookware.

To see if a piece of cookware will work on your induction cooktop, try to stick a magnet to it. If the magnet clings firmly to the bottom of the cookware, the cookware will work on your induction cooktop.

Cookware sold as induction-ready will often have a symbol printed on the bottom by the manufacturer.

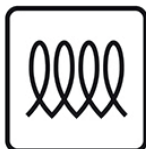

Figure 3: Induction symbol

## The Magnet Test

To see if a piece of cookware will work on your induction cooktop, try to stick a magnet to it (see Figure 2).

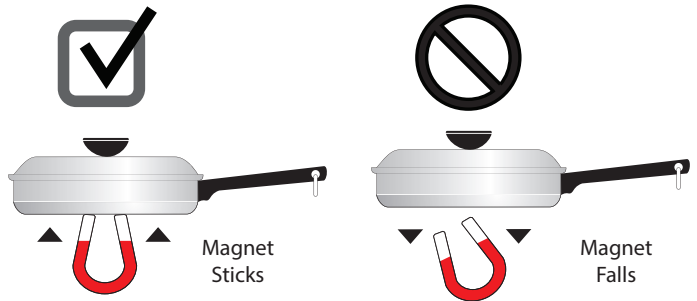

Figure 4: Magnet test

If the magnet clings firmly to the bottom of the cookware, it will work on your induction cooktop. If the magnet clings weakly or not at all, the cookware will not heat up on your induction cooktop.

## CAUTION

Proper cookware on an operating induction cooking zone will heat up very quickly. If an empty piece of cookware is left on an operating induction cooking zone, the rapid change in temperature may warp or damage the cookware.

Do NOT place hot cookware on the control panel. The heat may damage the electronic parts.

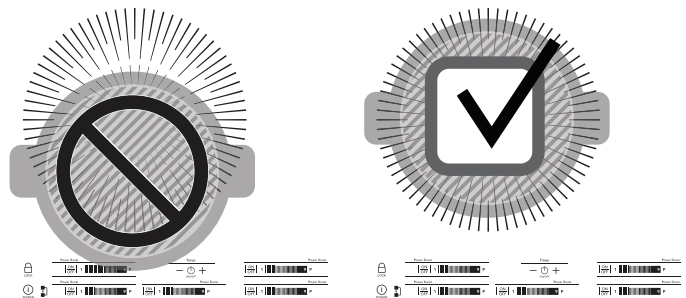

Figure 5: Keep hot cookware away from controls

## BEFORE SETTING SURFACE CONTROLS

### Pan Sensing

When the cooktop is on, the cooking zones automatically detect when cookware is placed on the zone. The control for that zone will light up, making it easy to know which section of the control to use for that cooking zone.

Figure 6 shows conditions that can prevent pan detection.

If you remove a pan from an active cooking zone, the zone will turn off after 30 seconds.

If the cooktop does not detect cookware in any zone for 30 seconds, the whole cooktop will turn off.

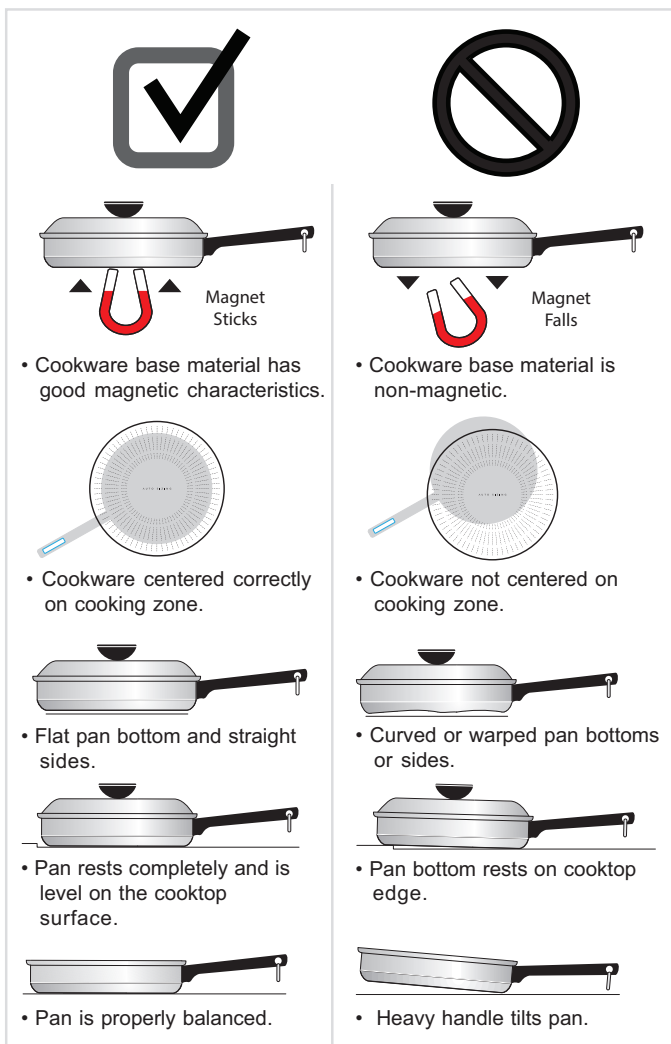

**Figure 6: Pan sensing conditions**

### Minimum and Maximum Pan Size

The cooktop graphics are guides to minimum and maximum pan size for each cooking zone. For best results, use cookware that matches the size of the cooking zone.

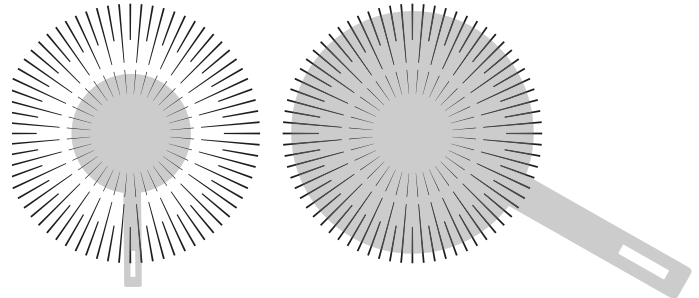
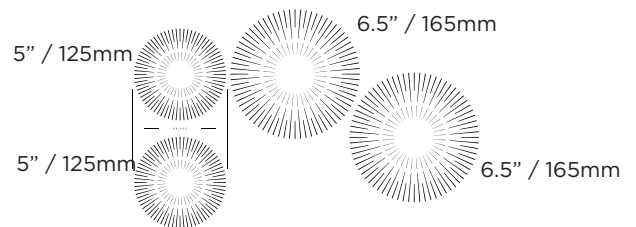

**Figure 7: Min / max pan size**

The inner ring on each cooking zone indicates the smallest pan size for the zone (Figure 8).

The outer ring on the cooktop graphic indicates the largest pan size for that zone (Figure 9).

Cookware that is too small for a zone may not activate the cookware detection sensor. Cookware that is much larger than a cooking zone will still cook, but may be slower and uneven. If your cookware is not a perfect match, it is best to use a zone a little smaller than the bottom of the cookware.



**Figure 8: Cookzone sizes, 4 zones**

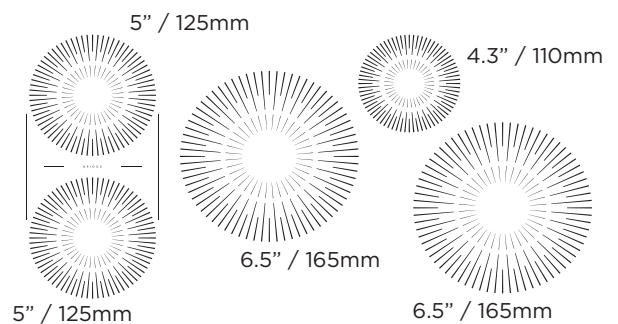

**Figure 9: Cookzone sizes, 5 zones**

# 12

## BEFORE SETTING SURFACE CONTROLS

---

### Hot Surface Indicator

When a cooking zone is turned off, it may remain hot due to contact with hot cookware. The Hot Surface Indicator (H) will come on and remain visible until the cooking zone cools to a safe temperature.



**Figure 10: Hot Surface indicator**

### Key-Stuck Function

If a control key is held for more than 10 seconds, the cooktop will sound an alert of 5 tones. If the key is still held after the alert sound, the cooktop will switch off. This function will also activate if the a zone slider is continually held or adjusted for 10 seconds.

Key-Stuck could be activated by such things as leaving objects on the cook zone controls, some spills on the controls, or resting hands on the controls.

### Lock or Unlock the Cooktop

The lock function deactivates most of the controls on the cooktop to keep cooking zones from being changed by accident.



**LOCK**  
**Figure 11: Lock key**

#### To lock the controls while cooking:

1. Set the cooking zones to the desired settings.
2. Press the **Lock** key.

To unlock the controls, press the **Lock** key again.

Even with the controls locked, you can turn a cooking zone off by pressing its **On/Off** key.

#### To set the lock for child safety:

1. Press the **Power** key to turn the cooktop on.
2. Press the **Lock** key and hold it for 4 seconds. The lock icon will turn red.
3. Press the **Power** key to turn the cooktop off.

When the cooktop is locked for safety, two options are available to unlock it:

#### Complete unlock:

1. Press the **Power** key to turn the cooktop on.
2. Press the **Lock** key and hold it for 4 seconds. The lock will deactivate.
3. Press the **Power** key to turn the cooktop off.

#### Temporary unlock:

1. Press the **Power** key to turn the cooktop on.
2. Hold the **lock** key for 4 seconds.
3. Set the cooking zones.

When the cooking process is finished and the cooktop is turned off, the Lock function will be still active.

### CAUTION

- Although induction cooking zones do not directly generate heat, **they can become hot from contact with hot cookware**. Burns may occur if a cooking zone or the surrounding area is touched before it has cooled to a safe temperature.
- **Do not** place flammable items such as plastic salt and pepper shakers, spoon holders, or plastic wrapping on top of the range when it is in use. Heat radiating from cookware could cause these items to melt or ignite. Potholders, towels, or wooden spoons could catch fire if placed too close to hot cookware.
- **Do not** use aluminum foil to line any part of the cooktop. Improper installation of these liners may result in risk of electric shock or fire. If these items melt on the cooktop, they will damage the cooktop.

### Moving Cookware on a Smooth Cooktop

It's best to lift cookware before moving it on the ceramic glass cooktop. Cookware that has a rough or dirty bottom can mark and scratch the ceramic glass surface. Always start with clean cookware.

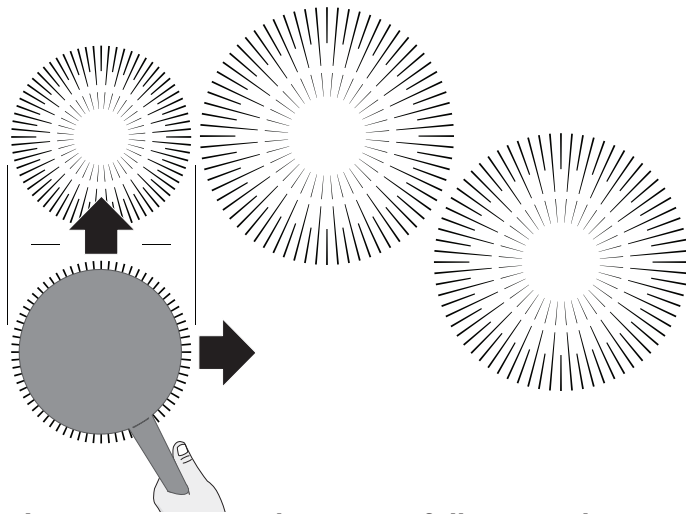

Figure 12: Move cookware carefully on cooktop

### Power Management

Your induction cooktop has 2 or 3 generators and 4 or 5 cooking zones, depending on the model. A generator may power 1 or 2 cooking zones. If you use more than one cooking zone on high power at the same time and they are on the same generator, the cooktop may need to manage power to the two cooking zones.

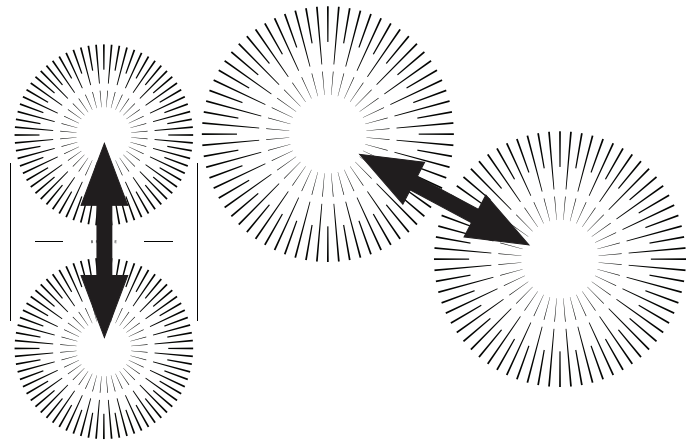

Figure 13: Power management, 4 cook zones

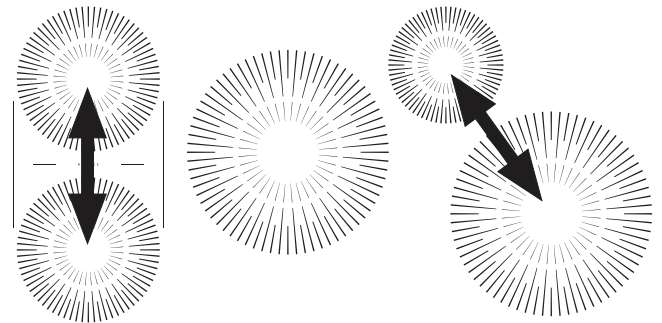

Figure 14: Power management, 5 cook zones

To get the best performance from your cooktop, start cooking on only one cooking zone. After the first piece of cookware has reached cooking temperature, then start cooking on the second cooking zone.

# 14 BEFORE SETTING SURFACE CONTROLS

---

## Home Canning

Be sure to read and observe all the following points when home canning with your appliance. Check with the USDA (United States Department of Agriculture) Web site and be sure to read all the information they have available as well as follow their recommendations for home canning procedures.

- Use only a completely flat bottom canner with no ridges that radiate from the bottom center when home canning. Heat is spread more evenly when the bottom surface is flat. Use a straight-edge to check canner bottom.
- Make sure the diameter of the canner does not exceed 1 inch beyond the surface element markings or burner.
- It is recommended to use smaller diameter canners on electric coil and ceramic glass cooktops and to center canners on the burner grates.
- Start with hot tap water to bring water to boil more quickly.
- Use the highest heat setting when first bringing the water to a boil. Once boiling is achieved, reduce heat to lowest possible setting to maintain that boil.
- Use tested recipes and follow instructions carefully. Check with your local Cooperative Agricultural Extension Service or a manufacturer of glass jars for the latest canning information.
- It is best to can small amounts and light loads.

Do not leave water bath or pressure canners on high heat for an extended amount of time.

---

## Cooktop Controls

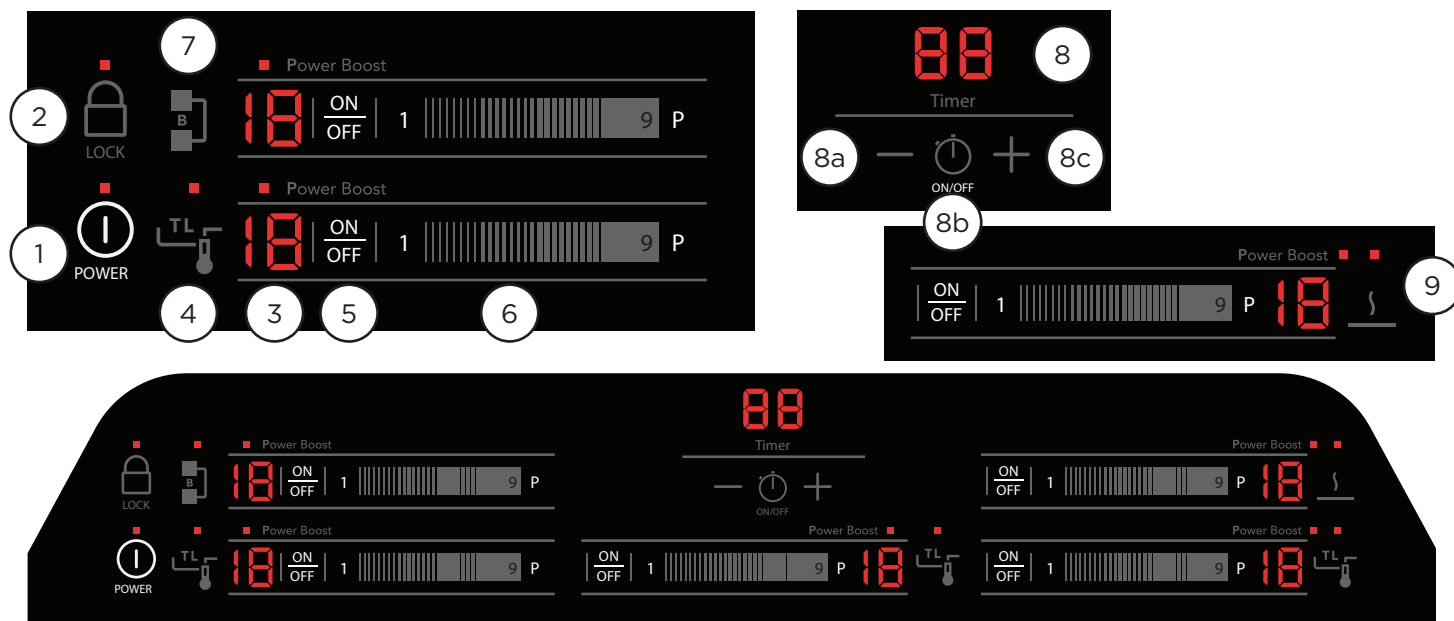

1. **Power:** Press to turn on or turn off the cooktop.
2. **Lock:** Lock the cooktop controls to prevent accidental activation of cooking zones.
3. **Cooking Zone Indicator:** The LEDs (4 or 5 depending on the model) indicate cook zones. The one corresponding to the control's cook zone turns red.
4. **TempLock:** Activates TempLock feature. When pressed, this feature uses a temperature sensor to monitor heat and adjust the power to maintain a consistent temperature during cooking. See page 17.
5. **Cooking Zone On/Off:** When cookware is on the cooking zone, press to turn the zone ON/OFF.
6. **Cooking Zone Power Level:** Slide a finger across or press a number to set the power level. Level 1 is low, level 9 is high, and P is the most powerful setting.
7. **Bridge:** The Bridge indicator is visible on Zone 1 if both left cooking zones detect cookware. The Bridge function makes the two left cooking zones work together to heat a long piece of cookware, like a griddle.
8. **Timer Indicator:** Shows the time currently left on the timer.
  - a. **Reduce Time (-):** Press to reduce the amount of time on the timer.
  - b. **Timer On/Off:** Press to turn the countdown timer on or off.
  - c. **Increase Time (+):** Press to increase the amount of time on the timer.
9. **Serve Warm:** Activates the Serve Warm feature. Serve Warm will set all of the cooking zones to a low power level to keep foods warm.

# 16 SETTING SURFACE CONTROLS

## Setting induction cooking zones

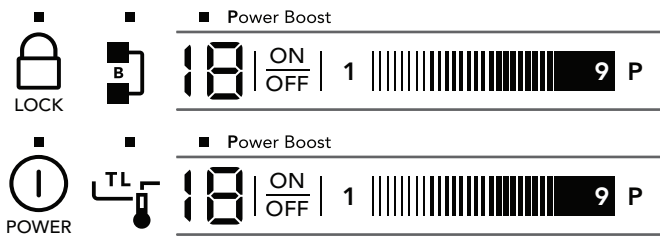

**Figure 15: Induction cooking zone control**

To operate an induction cooking zone:

1. Turn the cooktop on by pressing the **Power** key.
2. Place correctly sized cookware on the cooking zone. The controls for a zone won't activate unless cookware is detected.
3. Press the **On/Off** key for the active cooking zone. The indicator will turn red.
4. Set the cooking zone to the desired level (refer to Table 1) by pressing the number of the desired setting or **P**.
5. When cooking is complete, turn the induction cooking zone OFF by pressing its **On/Off** key or the **Power** key before removing the cookware. If all of the zones are off, the cooktop will automatically power off in 30 seconds.

At any time, you can change the setting for an active cook zone by pressing the number of the new setting.

### ➔ IMPORTANT

Do not leave empty cookware on an operating cooking zone. Cookware will heat very quickly and may be damaged or warped if left on the cooking zone empty.

### ⓘ NOTE

A cooking zone will not become active without proper cookware in position. See “Key-Stuck Function” on page 12page 11.

If the cooktop does not detect cookware within 30 seconds, it will turn off.

## Suggested induction cooking zone settings

Start most cooking operations on a higher setting and then turn to a lower setting to finish cooking.

The suggested settings found in Table 1 below are based on cooking with medium-weight stainless steel pans with lids. Settings may vary when using other types of pans.

**Electrolux Induction Recommendations**

	Temp Range	Power Level	Description
Keep Warm 145°-160°F	Low	1	Keep foods warm
	Medium Low	2-4	Continue cooking, poach, stew
Simmer 185 - 200°F	Medium	5-6	Maintain a slow boil, thicken sauces and gravies, steaming, cooking
	Medium High	7-8	Continue a rapid boil, fry, or deep fry
	High	9	Start most foods, maintain water at a boil, pan cooking, searing
	Power Boil	P	Start heating pans that contain large amounts of food or to bring pots of water to boil

**Table 1: Suggested induction cooking zone settings**

### NOTE:

- The size and type of the cookware used and the amount and type of food being cooked will influence the setting needed for best cooking results.
- The Max setting is available after activating a cooking zone by pressing the **MAX** key. The cooktop will remain on Max for up to 10 minutes. After 10 minutes, the cooking zone will automatically change to the high (9) setting.
- The Hot Surface indicator (Hot) will show in the setting indicator when heat is detected in a cook zone that has been turned off. The indicator will remain on until the heated surface area has cooled sufficiently.



## ■ TempLock

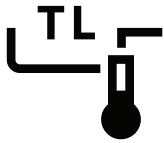

TempLock uses a temperature sensor to maintain a consistent temperature when cooking. When cool batter, liquid, or food is added to a hot pan, the pan cools down a little.

TempLock senses this change and will use extra power to maintain the desired temperature setting. The feature also lets you know when your cookware is preheated, so making pancakes or sautéing fresh food has better results.

The temperature of your cookware will depend on the level you select and the material of the cookware you use. Experiment a little to determine what works for you for cooking various dishes. Different pots and pans will hold at different temperatures, so you will need to learn how your cookware works with this feature.

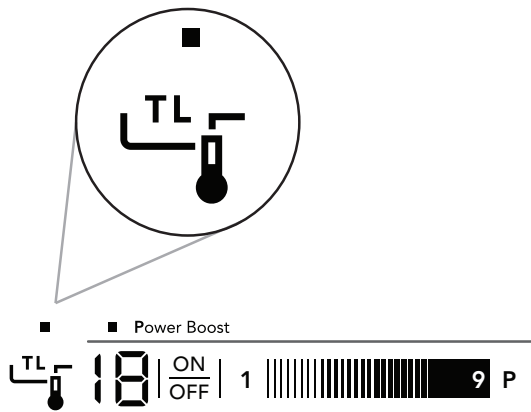

**Figure 16: TempLock Indicator**

TempLock is available for some cooking zones when they are active.

Press the **TempLock Indicator** to activate the TempLock function. The indicator turns red. Press a number key to select one of the 9 preset cooking levels.



**Figure 17: TempLock Set**

## **i** NOTE

To get an idea of how hot a piece of cookware will get at a particular setting, try the Magnet Test (page 10). The more strongly a magnet clings to the cookware, the hotter that cookware will get at any particular setting on the cooktop.

To get consistent results, use the same piece of cookware for particular cooking tasks.

When using small amounts of oil for frying or sautéing, add the oil after the pan is preheated.

Keep an eye on your cookware during preheat. Induction is powerful, and letting cookware get too hot while empty may warp or damage it.

## Preheat Indicators

While the cooking zone is heating, the square above the TempLock Indicator will flash. When the temperature is reached, the square will stay lit steadily.

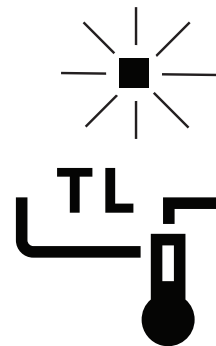

**Figure 18: TempLock heating indicator**

You can change the TempLock setting at any time by pressing another number key. The animated sequence of squares will start again until the new temperature is reached.

To deactivate the TempLock function, press the **TempLock Indicator**.

# 18 SETTING SURFACE CONTROLS

## ■ Bridge Function



The Bridge function allows you to use an extra-long piece of cookware such as a griddle on the left side of your cooktop.

If one of the left cook zones is active and cookware is detected in both of the left zones, the bridge function becomes available and the **Bridge Indicator** will light up.

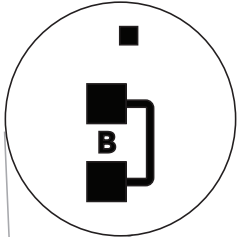

Figure 19: Bridge Indicator

Touch the **Bridge Indicator** to activate the bridge function. The **Bridge Indicator** will turn red. The cook zone indicator for the other bridge cook zone will also turn red, and the cook zone setting for both of the bridged zones will match. The setting controls for the front left zone will control both of the bridged zones as long as the bridge function is active.

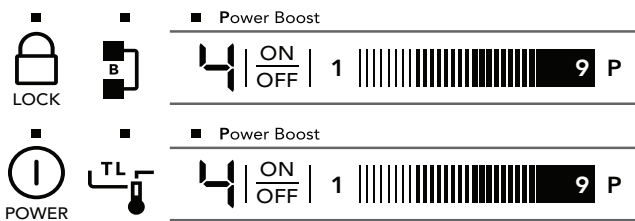

Figure 20: Active bridge function

At any time, you can change the setting for the bridged cook zones by pressing the number of the new setting on the active control.

To deactivate the bridge function, press the **Bridge Indicator** or deactivate one of the bridged cooking zones by pressing its **On/Off** key.

## ■ Serve Warm



Serve Warm allows you to keep cooked food warm for serving. When you activate Serve Warm, all active cooking zones will be set to a low setting.

To activate Serve Warm, press the **Serve Warm Indicator**. The indicator will turn red, and you will see the settings change on the active cooking zones.

To deactivate Serve Warm, press the **Serve Warm Indicator** again. All of the active cooking zones will turn off. You can also press the main **Power** key to turn the cooktop off.

### ! CAUTION

Serve Warm is not intended to cook food. Only use Serve Warm with food that is already cooked. Cover pots with lids to maintain proper serving temperature.

### Setting the Timer (36" Model Only)

The cooktop has a timer function to remind you when food has been cooking for a specified amount of time.

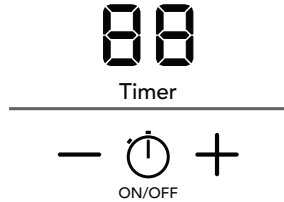

**Figure 21: Cooktop Timer**

To set the timer:

1. Press the Timer On/Off key (⌚) to activate the timer. The countdown timer and the + and - keys will become visible. The timer will show 00.
2. Press + and - to set the desired number of minutes. You can press and hold the + or - key to change the number of minutes faster.

The timer will start counting down a few seconds after you have finished setting it, when the specified time has elapsed, the timer will flash, and a tone will sound. Press the +, the -, or the Timer On/Off key (⌚) to stop the signal.

At any time, you can adjust the remaining time with the + and - keys.

At any time, you can deactivate the timer by pressing the Timer On/Off key (⌚).

**Important:** When the timer stops or the tone sounds, the cooking zones will continue to operate. The timer does not affect the cooking zone settings in any way.

# 20 CARE AND CLEANING

Remove spills and any heavy soiling as soon as possible. Regular cleaning will reduce the difficulty of major cleaning later.

## CAUTION

Before cleaning any part of the appliance, be sure all controls are turned off and the appliance is cool.

If ammonia or appliance cleaners are used, they must be removed and the appliance must be thoroughly rinsed before operating. Follow manufacturer's instructions and provide adequate ventilation.

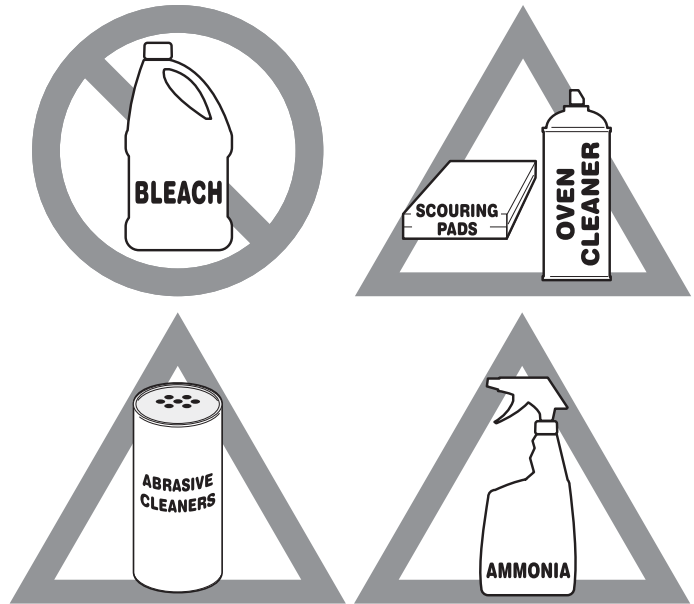

Figure 24: Use cleaners with caution

Surface or Area	Cleaning Recommendation
Aluminum and vinyl	Using a soft cloth, clean with mild dish detergent and water. Rinse with clean water, dry and polish with a soft, clean cloth.
Painted and plastic control knobs Painted body parts Painted decorative trims	Using a soft cloth, clean with mild dish detergent and water or a 50/50 solution of vinegar and water. Rinse with clean water, dry and polish with a soft, clean cloth. Glass cleaners may be used, but do not apply directly to surface; spray onto cloth and wipe.
Control panel	Using a soft cloth, clean with mild dish detergent and water or a 50/50 solution of vinegar and water. Do not spray liquids directly on the oven control and display area. Do not use large amounts of water on the control panel - excess water on the control area may cause damage to the appliance. Do not use other liquid cleaners, abrasive cleaners, scouring pads, or paper towels - they will damage the finish.
Control knobs	Using a soft cloth, clean with mild dish detergent and water or a 50/50 solution of vinegar and water. To remove control knobs: turn to the OFF position, grasp firmly, and pull off the shaft. To replace knobs after cleaning, line up the OFF markings and push the knobs into place.
Stainless Steel	Using a soft cloth, clean with mild dish detergent and water or a 50/50 solution of vinegar and water. Rinse with clean water, dry with a soft clean cloth. Do not use cleaners containing abrasives, chlorides, chlorine, or ammonia.
Smudge Proof™ Stainless Steel Black Stainless Steel	Using a soft cloth, clean with mild dish detergent and water or a 50/50 solution of vinegar and water. Rinse with clean water, dry with a soft clean cloth. Do not use appliance cleaner, stainless steel cleaner, or cleaner containing abrasives, chlorides, chlorine, or ammonia. These cleaners may damage the finish.

Surface or Area	Cleaning Recommendation
<p>Porcelain-enameled broiler pan and insert</p> <p>Porcelain door liner</p> <p>Porcelain body parts</p>	<p>Rinse with clean water and a damp cloth. Scrub gently with a soapy, non-abrasive scouring pad to remove most spots. Rinse with a 50/50 solution of clean water and ammonia. If necessary, cover difficult spots with an ammonia-soaked paper towel for 30 to 40 minutes. Rinse and wipe dry with a clean cloth. Remove all cleaners or future heating could damage the porcelain. Do not allow food spills with a high sugar or acid content (milk, tomatoes, sauerkraut, fruit juices or pie filling) to remain on porcelain surfaces. These spills may cause a dull spot even after cleaning.</p>
<p>Manual clean oven interior</p>	<p>The oven interior is porcelain coated and safe to clean using oven cleaners. Always follow manufacturer's instructions for cleaners. After cleaning, remove any oven cleaner or the porcelain may become damaged during future heating. Do not spray oven cleaner on any electrical controls or switches. Do not spray or allow oven cleaner to build up on the oven temperature sensing probe. Do not spray cleaner on oven door trim, door gasket, plastic drawer glides, handles or any exterior surfaces of the appliance.</p>
<p>Self-cleaning oven interior</p>	<p>Before setting a self-clean cycle, clean soils from the oven frame, areas outside the oven door gasket, and the small area at the front center of the oven bottom. See "Self Clean" on page 23.</p>
<p>Oven door</p>	<p>Use mild dish detergent and water or a 50/50 solution of vinegar and water to clean the top, sides, and front of the oven door. Rinse well. Glass cleaner may be used on the outside glass of the door. Ceramic smoothtop cleaner or polish may be used on the interior door glass. Do not immerse the door in water. Do not spray or allow water or cleaners to enter the door vents. Do not use oven cleaners, cleaning powders, or any harsh abrasive cleaning materials on the outside of the oven door.</p> <p>Do not clean the oven door gasket. The oven door gasket is made of a woven material which is essential for a good seal. Do not rub, damage, or remove this gasket.</p>
<p>Ceramic cooktop</p>	<p>See "Cooktop Cleaning" on page 22.</p>

# 22 CARE AND CLEANING

## Cooktop Maintenance

Consistent and proper cleaning is essential to maintaining your ceramic glass cooktop.

Prior to using your cooktop for the first time, apply a ceramic cooktop cleaning cream (available in most hardware, grocery, and department stores) to the ceramic surface. Clean and buff with a clean paper towel. This will make cleaning easier when soiled from cooking. Cooktop cleaning creams leave a protective finish on the glass to help prevent scratches and abrasions.

Sliding pans on the cooktop can cause metal markings on the cooktop surface. These marks should be removed immediately after the cooktop has cooled using cooktop cleaning cream. Metal marks can become permanent if not removed prior to future use.

Cookware (cast iron, metal, ceramic, or glass) with rough bottoms can mark or scratch the cooktop surface.

### Do not:

- Slide anything metal or glass across the cooktop.
- Use cookware with dirt or dirt build up on the bottom; always use clean cookware.
- Use your cooktop as a cutting board or work surface in the kitchen.
- Cook foods directly on the cooktop surface without a pan.
- Drop heavy or hard objects on the ceramic glass cooktop; they may cause it to crack.

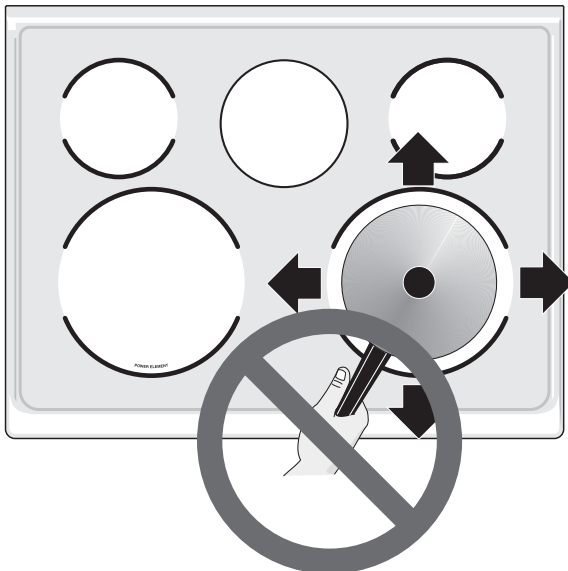

Figure 25: Cooktop care

## Cooktop Cleaning

### CAUTION

Before cleaning the cooktop, be sure the controls are turned to OFF and the cooktop is cool. The glass surface could be hot from contact with hot cookware, and burns may occur if the glass surface is touched before it has cooled sufficiently.

### WARNING

Do not use a cooktop cleaner on a hot cooktop. The fumes can be hazardous to your health, and can chemically damage the ceramic-glass surface.

### For light to moderate soil:

For light to moderate soil: Apply a few drops of cooktop cleaning cream directly to the cooktop. Use a clean paper towel to clean the entire cooktop surface. Make sure the cooktop is cleaned thoroughly, leaving no residue. Do not use the towel you use to clean the cooktop for any other purpose.

### For heavy, burned on soil:

Apply a few drops of cooktop cleaning cream directly to the soiled area. Rub the soiled area using a non-abrasive cleaning tool, applying pressure as needed. Do not use the pad you use to clean the cooktop for any other purpose.

If soils remain, carefully scrape soils with a metal razor blade scraper held at a 30 degree angle to the surface. Finish cleaning with cooktop cleaning cream.

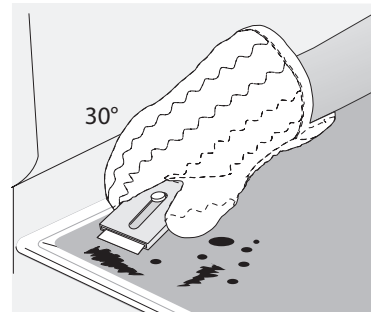

Figure 26: Cooktop cleaning

### IMPORTANT

Damage to the ceramic glass cooktop may occur if you use an abrasive type cleaning pad. Only use cleaning products that have been specifically designed for ceramic glass cooktops.

Let us help you troubleshoot your concern! This section will help you with common issues. If you need us, visit our website, chat with an agent, or call us. We may be able to help you avoid a service visit. If you do need service, we can get that started for you!

1-800-374-4432 (United States)  
**Frigidaire.com**

1-800-265-8352 (Canada)  
**Frigidaire.ca**

Problem	Cause / Solution
Entire appliance does not operate	Appliance not connected. Make sure power cord is plugged properly into outlet. Check your fuse box or breaker box to make sure the circuit is active.  Electrical power outage. Check house lights to be sure. Call your local electric company for service outage information.

<b>Cooktop Problems</b>	
Problem	Cause / Solution
Cooking zone does not heat or does not heat evenly.	Be sure the correct surface control knob is turned on for the element needed.  Be sure to use the correct cookware material type for induction cooking. Use cookware specifically identified by the manufacturer to use for induction cooking. If you're not sure, use a magnet to test whether the cookware type will work. If a magnet sticks to the bottom of the cookware, the material type is correct for induction cooking.  Be sure to read about pan-sensing in the Induction Cooking section and correct any pan-sensing issues in the checklist provided.
Control for the cooking zone does not work.	Incorrect cookware used. See "Using Proper Cookware" on page 10.  Cookware is the wrong size or incorrectly positioned in the cooking zone. See "Pan Sensing" on page 11  More than one control was pressed at a time. Make sure that when you try to configure the control, nothing is touching another control.
Areas of discoloration with metallic sheen on cooktop surface.	Mineral deposits from water and food. Remove them using cooktop cleaning creme applied to the ceramic surface. Buff with a non-abrasive cloth or sponge.
Scratches or abrasions on cooktop surface.	Coarse particles such as salt or hardened soils between cooktop and utensils can cause scratches. Be sure the cooktop surface and bottoms of utensils are clean before use. Small scratches do not affect cooking and will become less visible with time.  Cleaning materials not recommended for ceramic-glass cooktop have been used. Apply cooktop cleaning creme to the ceramic surface. Buff with a non-abrasive cloth or sponge.  Cookware with a rough bottom was used. Use smooth, flat-bottomed cookware.
Metal marks on the cooktop.	Sliding or scraping of metal utensils on cooktop surface. Do not slide metal utensils on the cooktop surface. Apply cooktop cleaning creme to the ceramic surface. Buff with a non-abrasive cloth or sponge. For more information, see "Cooktop Maintenance" on page 22.
Brown streaks or specks on cooktop surface.	Boil overs are cooked onto the surface. When cooktop is cool, use a razor blade scraper to remove soil. For more information see "Cooktop Maintenance" on page 21.

# 24 WARRANTY

## WARRANTY

Your appliance is covered by a one year limited warranty. For one year from your original date of purchase, Electrolux will pay all costs for repairing or replacing any parts of this appliance that prove to be defective in materials or workmanship when such appliance is installed, used and maintained in accordance with the provided instructions.

### Exclusions

This warranty does not cover the following:

1. Products with original serial numbers that have been removed, altered or cannot be readily determined.
2. Product that has been transferred from its original owner to another party or removed outside the USA or Canada.
3. Rust on the interior or exterior of the unit.
4. Products purchased "as-is" are not covered by this warranty.
5. Food loss due to any refrigerator or freezer failures.
6. Products used in a commercial setting.
7. Service calls which do not involve malfunction or defects in materials or workmanship, or for appliances not in ordinary household use or used other than in accordance with the provided instructions.
8. Service calls to correct the installation of your appliance or to instruct you how to use your appliance.
9. Expenses for making the appliance accessible for servicing, such as removal of trim, cupboards, shelves, etc., which are not a part of the appliance when it is shipped from the factory.
10. Service calls to repair or replace appliance light bulbs, air filters, water filters, other consumables, or knobs, handles, or other cosmetic parts.
11. Surcharges including, but not limited to, any after hour, weekend, or holiday service calls, tolls, ferry trip charges, or mileage expense for service calls to remote areas, including the state of Alaska.
12. Damages to the finish of appliance or home incurred during installation, including but not limited to floors, cabinets, walls, etc.
13. Damages caused by: services performed by unauthorized service companies; use of parts other than genuine Electrolux parts or parts obtained from persons other than authorized service companies; or external causes such as abuse, misuse, inadequate power supply, accidents, fires, or acts of God.

### DISCLAIMER OF IMPLIED WARRANTIES; LIMITATION OF REMEDIES

CUSTOMER'S SOLE AND EXCLUSIVE REMEDY UNDER THIS LIMITED WARRANTY SHALL BE PRODUCT REPAIR OR REPLACEMENT AS PROVIDED HEREIN. CLAIMS BASED ON IMPLIED WARRANTIES, INCLUDING WARRANTIES OF MERCHANTABILITY OR FITNESS FOR A PARTICULAR PURPOSE, ARE LIMITED TO ONE YEAR OR THE SHORTEST PERIOD ALLOWED BY LAW, BUT NOT LESS THAN ONE YEAR. ELECTROLUX SHALL NOT BE LIABLE FOR CONSEQUENTIAL OR INCIDENTAL DAMAGES SUCH AS PROPERTY DAMAGE AND INCIDENTAL EXPENSES RESULTING FROM ANY BREACH OF THIS WRITTEN LIMITED WARRANTY OR ANY IMPLIED WARRANTY. SOME STATES AND PROVINCES DO NOT ALLOW THE EXCLUSION OR LIMITATION OF INCIDENTAL OR CONSEQUENTIAL DAMAGES, OR LIMITATIONS ON THE DURATION OF IMPLIED WARRANTIES, SO THESE LIMITATIONS OR EXCLUSIONS MAY NOT APPLY TO YOU. THIS WRITTEN WARRANTY GIVES YOU SPECIFIC LEGAL RIGHTS. YOU MAY ALSO HAVE OTHER RIGHTS THAT VARY FROM STATE TO STATE.

### If You Need Service

Keep your receipt, delivery slip, or some other appropriate payment record to establish the warranty period should service be required. If service is performed, it is in your best interest to obtain and keep all receipts. Service under this warranty must be obtained by contacting Electrolux at the addresses or phone numbers below.

This warranty only applies in the USA and Canada. In the USA, your appliance is warranted by Electrolux Major Appliances North America, a division of Electrolux Home Products, Inc. In Canada, your appliance is warranted by Electrolux Canada Corp. Electrolux authorizes no person to change or add to any obligations under this warranty. Obligations for service and parts under this warranty must be performed by Electrolux or an authorized service company. Product features or specifications as described or illustrated are subject to change without notice.

**USA**  
**1-800-374-4432**  
Frigidaire  
10200 David Taylor Drive  
Charlotte, NC 28262



**Canada**  
**1.800.265.8352**  
Electrolux Canada Corp.  
5855 Terry Fox Way  
Mississauga, Ontario, Canada  
L5V 3E4



# FRIGIDAIRE®

A01704804 A 10/2021

welcome *home*

Our home is your home. Visit us if you need help with any of these things:



owner support



accessories



service



registration

(See your registration card for more information.)

Frigidaire.com  
1-800-374-4432

Frigidaire.ca  
1-800-265-8352

Use & care guide  
Guia de uso y cuidado  
Guide d'utilisation et d'entretien

30" and 36" Free-Standing Range Hood

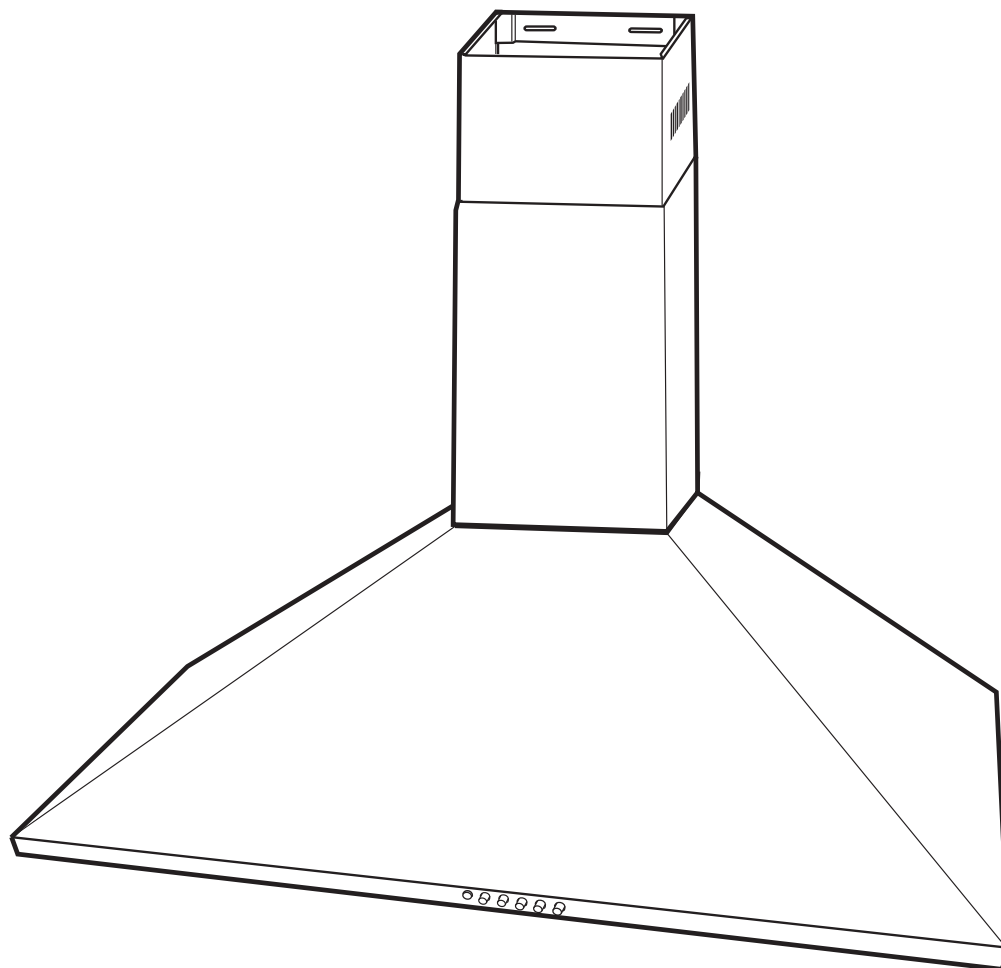

# 2 Finding information

## Table of contents

Please read and save this guide .....	02
Keep a record for quick reference .....	02
Important safety instructions .....	02-04
Electrical requirements .....	04-05
Intended use .....	05
Parts supplied .....	05
Installing the hood.....	05-11
Operation.....	11
Cleaning and maintenance.....	11-12
Technical data.....	12
Troubleshooting .....	12
Environmental protection.....	12
Warranty information .....	13

## Please read and save this guide

Thank you for choosing **Frigidaire**, the new premium brand in home appliances. This Use & Care Guide is part of our commitment to customer satisfaction and product quality throughout the service life of your new appliance.

We view your purchase as the beginning of a relationship. To ensure our ability to continue serving you, please use this page to record important product information.

## Keep a record for quick reference

Purchase date

---

Model number

---

Serial number

---

## NOTE

Registering your product with Frigidaire enhances our ability to serve you. You can register online at [www.frigidaire.com](http://www.frigidaire.com) or by dropping your Product Registration Card in the mail.

## Questions?

For toll-free telephone support in the U.S.: **1-800-944-9044** or Canada: **1-800-265-8352**

For online support and Internet production information visit <http://www.frigidaire.com>

## Important safety instructions

Do not attempt to install or operate this appliance until you have read the safety instructions in this manual. Safety items throughout this manual are labelled with a **Danger**, **Warning**, or **Caution** based on the risk type.

## Definitions

 This is the safety alert symbol. It is used to alert you to potential personal injury hazards. Obey all safety messages that follow this symbol to avoid possible injury or death.

## DANGER

**DANGER** indicates an imminently hazardous situation which, if not avoided, will result in death or serious injury.

## WARNING

**WARNING** indicates a potentially hazardous situation which, if not avoided, could result in death or serious injury.

## CAUTION

**CAUTION** indicates a potentially hazardous situation which, if not avoided, could result in minor or moderate injury.

## Important safety instructions

### **IMPORTANT**

Indicates installation, operation, or maintenance information which is important but not hazard-related.

### **Child safety**

Packing materials:

- Packing cartons covered with rugs, bedspreads, plastic sheets, or stretch wrap may become airtight chambers and can quickly cause suffocation.
- Remove the protective film covering the appliance before putting it into operation.
- Destroy or recycle the appliance's carton, plastic bags, and any other exterior wrapping material immediately after the product is unpacked. Children should never play with these items. **Danger of suffocation!**



### **IMPORTANT**

**PLEASE READ THESE INSTRUCTIONS CAREFULLY BEFORE INSTALLATION AND USE.**

**INSTALLATION MUST COMPLY WITH ALL LOCAL CODES.**

**IMPORTANT:** Save these instructions for the Local Electrical Inspector's use.

**INSTALLER:** Please leave these instructions with this appliance for the owner.

**OWNER:** Please retain these instructions for future reference.

### **DANGER**

Always switch off the electricity supply at the mains during installation and maintenance such as for light bulb replacement.

### **WARNING**

To reduce the risk of fire, electric shock, or injury to persons, observe the following:

- **FOR RESIDENTIAL USE ONLY.**
- Use this appliance only in the manner intended by the manufacturer. If you have questions, contact the manufacturer.
- Installation work and electrical wiring must be done by qualified person(s) in accordance with applicable codes & standards, including fire-rated construction.
- Sufficient air is needed for proper combustion and exhausting of gases through the flue (chimney) of fuel burning equipment to prevent back-drafting. Follow the heating equipment manufacturers guideline and safety standards such as those published by the National Fire Protection Association (NFPA), the American Society for Heating, Refrigeration and Air Conditioning Engineers (ASHRAE), and the local code authorities.
- When cutting or drilling into wall or ceiling, do not damage electrical wiring and other hidden utilities (e.g. gas pipes).
- Ducted systems must always be vented to the outdoors.

### **WARNING**

- Before servicing or cleaning the unit, switch power off at service panel and lock service panel disconnecting means to prevent power from being switched on accidentally. When the service disconnecting means cannot be locked, securely fasten a prominent warning device, such as a tag, to the service panel.

### **CAUTION**

For general ventilating use only. **DO NOT** use to exhaust hazardous or explosive materials or vapors.

### **CAUTION**

To reduce risk of fire and to properly exhaust air, be sure to duct air outside – do not vent exhaust air into spaces within walls, ceilings, attics, crawl spaces, or garages.

# 4 Important safety instructions

## Important safety instructions

### WARNING

To reduce the risk of fire, use only metal duct work. Install this hood in accordance with all requirements specified.

### WARNING

To reduce the risk of fire or electric shock, do not use this hood with any external solid state speed control device.

### WARNING

To reduce the risk of a cooker top grease fire:

- Never leave surface units unattended at high settings. Boilovers cause smoking and greasy spillovers that may ignite. Heat oils slowly on low or medium settings.
- Always turn hood ON when cooking at high heat or when flambéing food (i.e. Crepes Suzette, Cherries Jubilee, Peppercorn Beef Flambé).

### WARNING

- Clean ventilating fans frequently. Grease should not be allowed to accumulate on fan or filter.
- Do not use the range hood without the grease filters, or if the filters are excessively greasy.
- Use proper pan size. Always use cookware appropriate for the size of the surface element.

### WARNING

**NEVER PICK UP A FLAMING PAN - you may be burned.**

### WARNING

To reduce the risk of injury to persons, in the event of a cooker top grease fire, observe the following:

- Smother flames with a close-fitting lid, cookie sheet, or other metal tray, then turn off the gas burner or the electric element. Be careful to prevent burns. If the flames do not go out immediately, evacuate and call the fire department.
- Never pick up a flaming pan – you may be burned.
- Do not use water, including wet dishcloths or towels – a violent steam explosion will result.
- Use an extinguisher only if:
  - You know you have a class ABC extinguisher, and you already know how to operate it.
  - The fire is small and contained in the area where it started.
  - The fire department is being called.
  - You can fight the fire with your back to an exit.

### CAUTION

Always leave safety grills and filters in place. Without these components, operating blowers could catch onto hair, fingers and loose clothing.

## Electrical requirements

### IMPORTANT

Observe all governing codes and ordinances.

It is the customer's responsibility:

- to contact a qualified electrical installer.
- to assure that the electrical installation is adequate and in conformance with National Electrical Code, ANSI/NFPA 70 – latest edition\*, or CSA Standards C22.1-94, Canadian Electrical Code, Part 1 and C22.2 No.0-M91-latest edition\*\* and all local codes and ordinances.

If codes permit and a separate ground wire is used, it is recommended that a qualified electrician determines that the ground path is adequate.

- Do not ground to a gas pipe.
- Check with a qualified electrician if you are not sure range hood is properly grounded.
- Do not have a fuse in the neutral or ground circuit.

## ➔ IMPORTANT

Save installation instructions for electrical inspector's use.

The range hood must be connected with copper wire only.

The range hood should be connected directly to the fused disconnect (or circuit breaker) box through metal electrical conduit.

Wire sizes must conform to the requirements of the National Electrical Code ANSI/NFPA 70 – latest edition”, or CSA Standards C22.1-94, Canadian Electrical Code Part 1 and C22.2 No.0-M91 – latest edition\*\* and all local codes and ordinances.

A U.L.- or C.S.A.-listed conduit connector must be provided at each end of the power supply conduit (at the range hood and at the junction box).

Copies of the standards listed may be obtained from:

\* National Fire Protection Association Batterymarch Park Quincy, Massachusetts 02269

\*\* CSA International 8501 East Pleasant Valley Road Cleveland, Ohio 44131-5575

Power requirement:









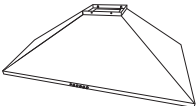
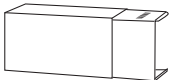

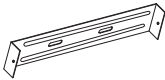
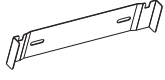
120V~, 60Hz, 15 or 20A branch circuit

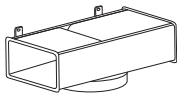
## Intended use

- Your range hood is intended for exhaust operation only. This range hood is not recommended to be used over indoor grills. Do not use it to exhaust hazardous or explosive materials or vapors.

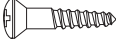
## Parts supplied

No.	Part	Qty.
1	 Range hood	1
2	 Upper and lower chimney	1 + 1

3		Upper bracket	1
4		Lower bracket	1
5		Collar	1
6		Recirculation kit (optional accessories) FHW RKT55LS	1
7		Bulb 20W, 120V~, GU10 (pre-assembled)	2
8		Long screw (4mm x 32mm)	8
9		Wall plug	8
10		Short screw (4mm x 12mm)	4
11		Wood screw (4mm x 50mm)	4
12		Stainless steel screw (3.5mm x 10mm)	2
13		Short screw (3.5mmx8mm)	2
14		10' extension chimney kit (optional accessories) FHW10X55LS	1
15		Assembly template (stencilled)	1

# 6 Installing the hood

## Installing the hood

### ▶ IMPORTANT

We recommend that two people carry out the installation. Pay attention to the procedure described in the assembly instructions.



### Preparation

- Determine the exact location of the range hood.
- Plan the route for venting exhaust to the outdoors (fig. ③).
- Plan the power connection prior to installation so that electrical wiring will not be visible afterwards.
- **House wiring location:** The junction box is located on the top right side of the hood. Wiring should enter the back wall at least 20" above the bottom of the installation height, and within 3-3/8" to 4-3/4" of the right side of the centerline (fig. ①/②).

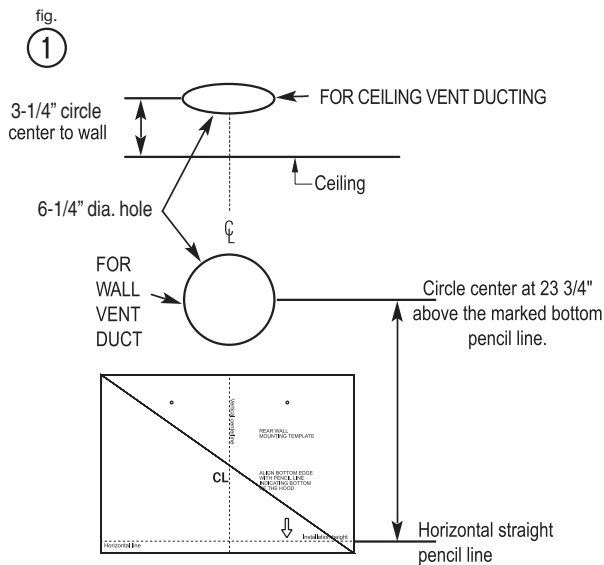

- Use the shortest and straightest duct route possible.
- The wall breakthrough must be carried out by a professional prior to installing the range hood. Pay attention to the length of the exhaust hose when planning the wall breakthrough. The exhaust hose must reach the outer edge of the wall without any kinks. **Important!** If the exhaust hose leads through an outer wall, install a wall cap with damper or roof cap at the exterior opening (not delivered). This can be installed by the professional that performs the wall breakthrough.
- If open fireplaces are operated in the same room,

ask your local chimney sweeper about the local regulations prior to installation.

- If you are renting, then approval must be obtained from the owner of the property.
- **Attention!** In order for the range hood to reach optimal performance, install it over the middle of the cooking area.
- The following accessories are required to mount the range hood (not included):
  - Exhaust duct
  - Power drill with 3/16" and 1/8" bits
  - Screwdriver
  - Level
  - Cable detector
  - Measuring tape
  - Duct tape

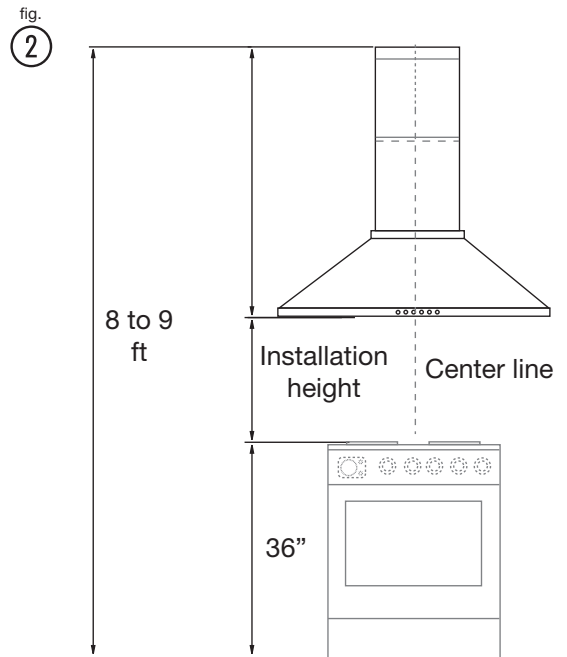

### Ducting installation guidelines

- For safety reasons, ducting should vent directly outdoors (not into an attic, underneath the house, into the garage or into any enclosed space).
- Keep duct runs as short and straight as possible.
- Duct fittings (elbows and transitions) reduce air flow efficiency.
- Back to back elbow and "S" turns give very poor delivery and are not recommended.
- A short straight length of duct at the inlet of the remote blower gives the best delivery.
- Transition to duct from the integral blower or remote duct transition as close to the downdraft as is possible.
- Use a suitable 6" round duct.
- Flexible metal round ducts should only be used when no other duct fitting exists. Limit use to short lengths and do not crush when making corners.

## Examples of possible ducting or air recirculation

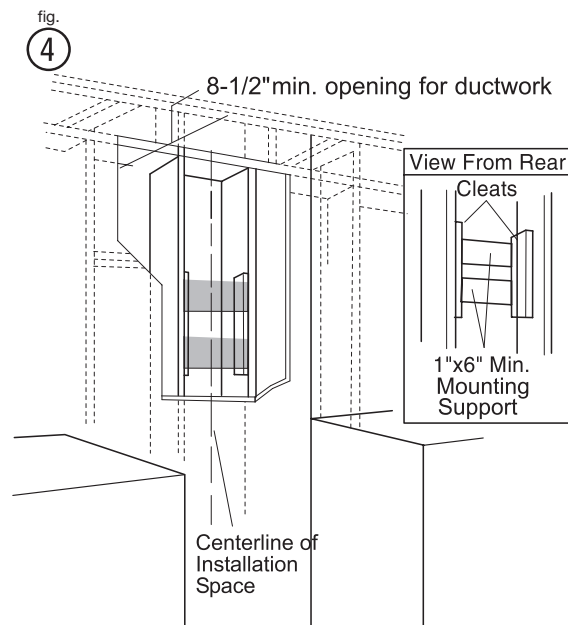
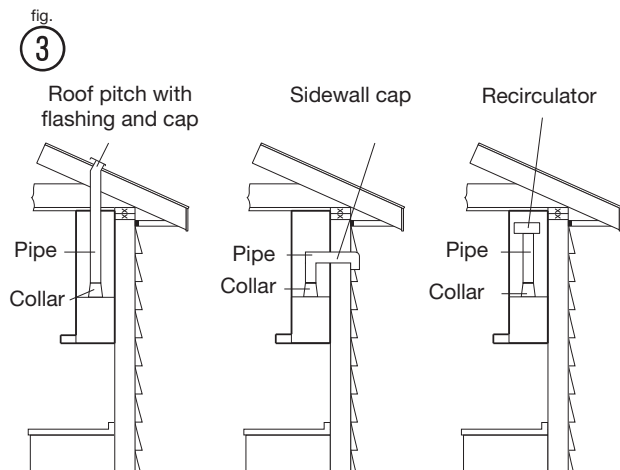

## Installing range hood to the wall (Exhaust operation)

### → IMPORTANT

This range hood is very heavy. Adequate structure and support must be provided in all types of installations.

### Install framing for hood support

- If drywall is present, mark the screw hole locations.
- Cut away enough drywall to expose 2 vertical studs at the holes location indicated by the template. Install two horizontal supports at least 1" x 6" between two wall studs at the bottom and top mounting holes installation location (fig. 4).
- The horizontal support must be flush with the room side of the studs. Use cleats behind both sides of the support to secure to wall studs.
- Reinstall drywall and refinish.

### → IMPORTANT

Framing must be capable of supporting 100 lbs.

#### Step 1:

- Make sure that no cables or pipes will become damaged (e.g. electric, gas, water; test the areas in question with a cable detector).
- Using supplied template (15), mark and drill 8 holes in the wall. Drill the holes according to the measured distances from the diagram (fig. 5).
- Upper/Lower bracket (3, 4): Insert 4 wall plugs (9) into the 4 drilled holes.
- Range hood (1): Installation is depending on wall type:

Wall type	Required fasteners
Wood	No wall plugs (9) required
Brick/Concrete	4 wall plugs (9)



# 8 Installing the hood

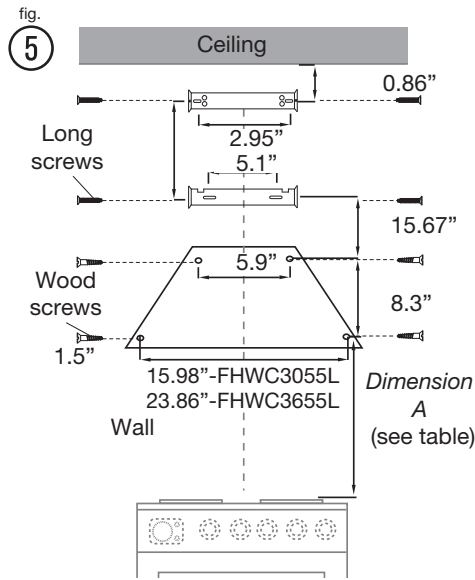

## Desired range hood distance above a 36" high cook top

Ceiling height			
	8 Feet	9 Feet	10 Feet *1
	A*2	A*2	A*2
26"*3	27-5/16"		
27"*3	28-5/16"	28-5/16"	
28"*3	29-5/16"	29-5/16"	29-5/16"
29"*3	30-5/16"*4	30-5/16"	30-5/16"
30"*3	31-5/16"*4	31-5/16"	31-5/16"
31"*3	32-5/16"*4	32-5/16"	32-5/16"
32"*3	33-5/16"*4	33-5/16"	33-5/16"
33"		34-5/16"	34-5/16"
34"		35-5/16"	35-5/16"
35"		36-5/16"	36-5/16"

\*1: with 10' Extension chimney kit FHW10X55LS (14) (not supplied). Please call Frigidaire at 1.800.944.9044 to order this kit.

\*2: "Dimension A" in the chart represents the height from cook top to where the bottom screw mounting holes would be located.

\*3: Recommended mounting height

\*4: Recirculation Kit cannot be installed.

### Step 2:

- Install the range hood (1) either with wood screws or long screws, depending on the wall type:

Wall type	Required screws
Wood	4 wood screws (11)
Brick/Concrete	4 long screws (8)

- Insert 2 screws (8 or 11) in the top location, but do not fully insert the screws (fig. 8). Mount the range hood (1) to the wall and tighten the screws. Insert and tighten the 2 remaining screws on the bottom location of the range hood (fig. 6/7).
- Attach the collar (5) to the range hood (1). Secure with 2 short screws (8) (fig. 9).

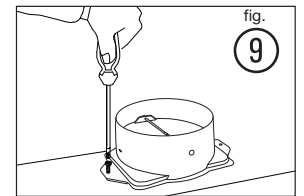
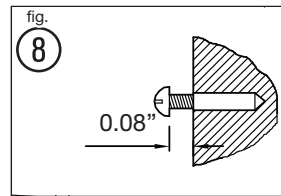
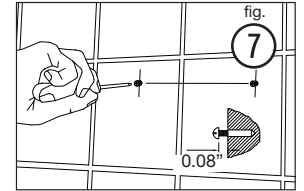
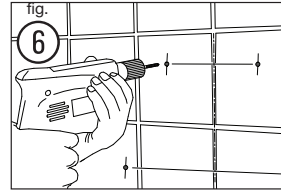

### NOTE

Sometimes, sponge tape covers the holes. If the holes are located behind the sponge tape, simply insert the screw through the sponge tape.

### Step 3:

- Mount upper and lower brackets (3, 4) on the wall. Secure with the remaining 4 sets of long screws (8). The notches of the lower bracket should be facing up towards the ceiling (fig. 10).
- Attach the exhaust duct. In the example below a round metal duct furnace pipe has been used. The airtight connection of the exhaust duct should then be improved with a duct tape. This ensures tight fit and that no grease vapors will escape from the duct (fig. 11).

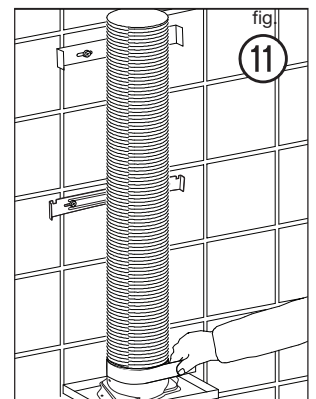
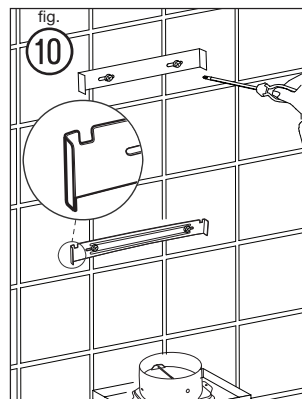

## Electrical connections

### DANGER

Danger of electric shock! All fittings must be installed by a competent person in accordance with current wiring regulations and local building regulations. If in doubt, consult a qualified electrician.

### IMPORTANT

Always switch off the electricity supply at the mains during installation, cleaning and maintenance. We recommend that the fuse is withdrawn or circuit breaker switched off at the distribution board while work is in progress.

#### Step 4:

- Loosen the 2 short screws from the junction box (fig. 12).

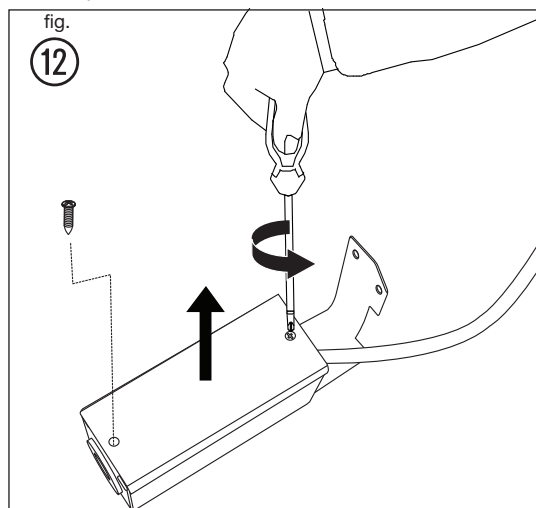

- Connect the incoming positive, neutral and ground cables to the respective terminals. The ground cable is already pre-assembled onto the junction box to provide grounding (fig. 13).

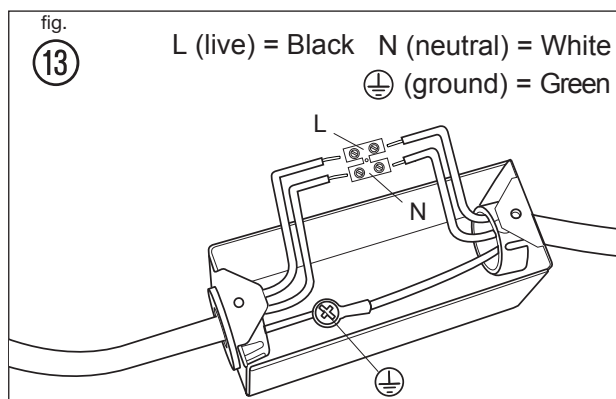

- Mount the junction box onto the range hood using 2 short screws (13) (fig. 14).

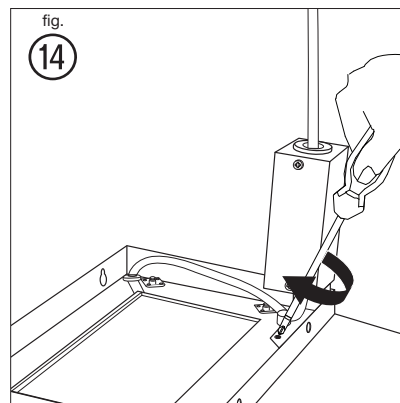

#### Step 5:

- Insert the upper chimney (2) into the lower chimney (3) from top to bottom (fig. 15).
- Mount lower chimney (2) on the range hood (1).
- Fit the tab, which is bend by 90 degrees, into the lower bracket notch and mount to the lower bracket (4) (fig. 16/17).
- Fix it with 2 screws (12) (fig. 17).

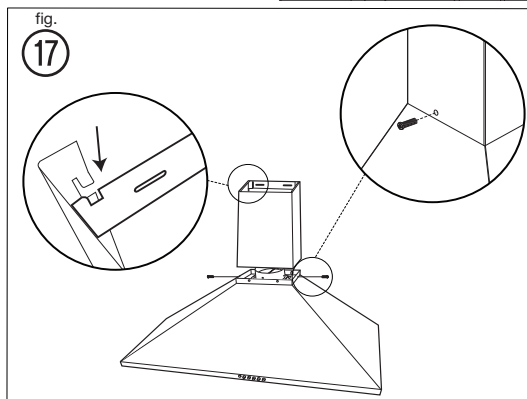
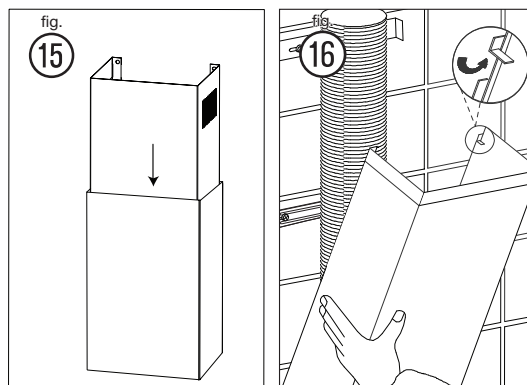

- Pull the upper chimney (2) to the upward position to match the screw hole of the upper bracket. Mount to the upper bracket (3) with 2 side screws (10) (fig. 18).

# 10 Installing the hood

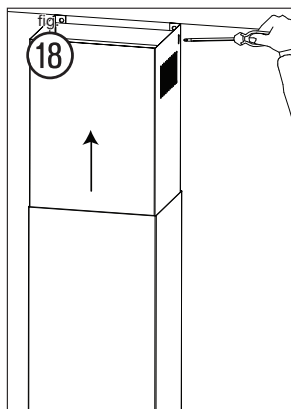

## CAUTION

Danger of injury. The chimney skirts may have some sharp edges.

## Exhaust operation

- During exhaust operation, the range hood removes air from a room. If other fire sources that require the surrounding air for combustion are being operated in the same room, (e.g. gas, oil or coal heaters), the oxygen they require is taken away. Thus flames could be suffocated and gas could leak out or the fumes could be drawn back into the room.
- In order to guarantee a safe operation, there should be non-closable openings in doors, windows to ensure a fresh supply of combustion air. This will prevent the combustion fumes from being drawn back into the room.
- When assessing the measures necessary, always take the entire ventilation system of the house into consideration.
- Never secure the range hood to a ventilation duct, or a room or exhaust gas chimney! Do not let the air that is removed from the room be drawn into a duct where warm air is circulating. The extracted air should only be drawn outdoors through a separate ventilating duct that is only for the extractor hood.
- When in extraction mode, air in the room is being removed by the range hood. Please make sure that proper ventilation measures are being observed. The range hood removes odors from room but not steam.
- There shall be adequate ventilation of the room when the range hood is used at the same time as appliances burning gas or other fuels (not applicable to appliances that only discharge the air back into the room).

- The air must not be discharged into a flue that is used for exhausting fumes from appliances burning gas or other fuels (not applicable to appliances that only discharge the air back into the room).

## Air recirculation operation

- **Recirculated air:** Kitchen fumes are removed and after purification are fed back into the room through the upper ventilation openings. The purification takes place via metallic anti-grease filter. No wall breakthrough is required for *recirculated air operation*.

## Installing range hood to the wall in recirculation mode

- For the operation of the range hood with *recirculation mode* a recirculator, model no. FHWRKT55LS, needs to be obtained. Please call Frigidaire at 1.800.944.9044 to order this kit.
- Follow steps 1 to 4 from *Installing range hood to the wall (Exhaust operation)* chapter.
- To install the recirculator (6) drill 2 additional holes in the wall. Use the template included in recirculation kit for proper position.
- Fix the recirculator (6) to the wall with 2 sets of long screws (8) and wall plugs (9) (fig. 19).
- Attach the exhaust duct on the bottom of the recirculator (6).
- Follow step 5 from *Installing range hood to the wall (Exhaust operation)* sub-chapter.

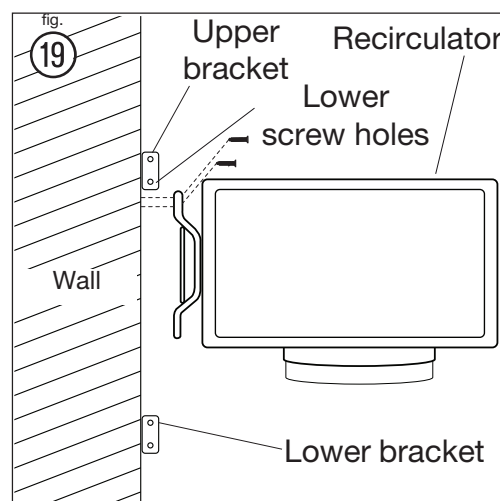

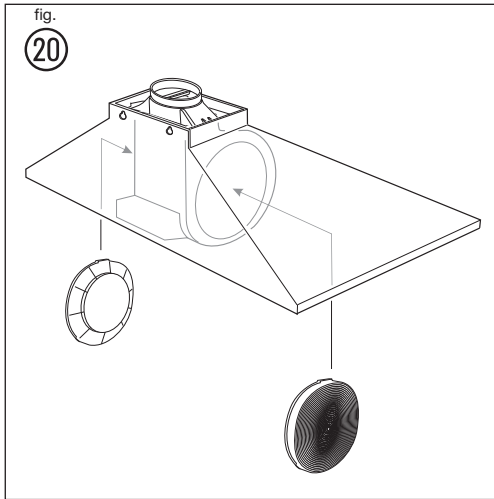

- Take out the grease filters and fit charcoal filters to two lateral sides of the motor blower. Assemble back the grease filters (fig. 20).

## Operation

- Press one of the speed (• / •• / •••) buttons to turn the appliance on.

Button	Function
○	Press button ○ to switch the appliance off (pilot lamp is lit when appliance is switched on).
•	Press button • for low speed.
••	Press button •• for medium speed.
•••	Press button ••• for high speed.
☀	Press button ☀ to turn on lights. Press again to switch lights off.

### For best performance

#### NOTE

Continuous use of range hood while cooking helps keep the kitchen comfortable and less humid.

It also reduces cooking odors and soiling moisture that create a frequent need for cleaning.

- Turn on the range hood before starting to cook.
- Clean the filters frequently (refer to **Cleaning and maintenance** below).
- Use low speed for normal use and higher speed for strong odors or fumes.

## Cleaning and maintenance

### Cleaning

#### ⚠ DANGER

Always switch off the electricity supply at the mains during installation, cleaning and maintenance such as for light bulb replacement.

#### NOTE

The efficiency of the range hood depends on the cleanliness of the intake and filters. Grease should not be allowed to accumulate on hood or filter.

- Clean the appliance in the following intervals:

<b>Regularly</b>	Use a soft cloth moistened with hand-warm mildly soapy water or household cleaning detergent. Never use metal pads, chemical, abrasive material or stiff brush to clean the appliance.
<b>Monthly</b>	<p><b>Metallic anti-grease filter:</b> The filter collects grease, smoke and dust so the filter is directly affecting the efficiency of the range hood. If not cleaned, the grease residue (potential flammable) will saturate on the filter. Clean it with household cleaning detergent. The filter is dishwasher safe.</p> <p><b>Recirculator:</b> clean the ventilation openings on the top sides.</p>
<b>every 4 - 6 months</b>	<p><b>Charcoal filters:</b></p> <ul style="list-style-type: none"> <li>• If the model is not vented to the outside, the air will be recirculated through disposable charcoal filters that help remove smoke and odors.</li> <li>• The charcoal filters cannot be cleaned, they must be replaced regularly (depending on range hood usage).</li> <li>• <b>NOTE:</b> Do not rinse or put charcoal filters in a dishwasher.</li> <li>• <b>NOTE:</b> Charcoal filters are not included with the range hood. Please call Frigidaire at 1.800.944.9044 to order this kit. When calling our customer service center, also have this range hood's model number ready.</li> </ul>

# 12 Troubleshooting

## ➔ IMPORTANT

Clean the filter every month to prevent risk of fire.

### Maintenance

- User servicing – Do not repair or replace any part of the appliance unless specifically recommended in the manual. All other servicing should be referred to a qualified technician.

### Light bulb replacement

- Switch the appliance off and disconnect the power supply.
- In order to replace the light bulb (7), the metallic anti-grease filter should be detached first.
- Pull the spring lock downward (fig. 22).
- Rotate and pull one or both of the light bulbs from the holders and replace with new light bulb(s) of the same type (GU10, 20W, 120V~) (fig. 23/24).
- Replace the metallic anti-grease filter and make sure it locks in place.

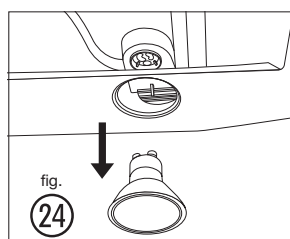
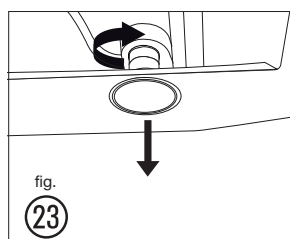
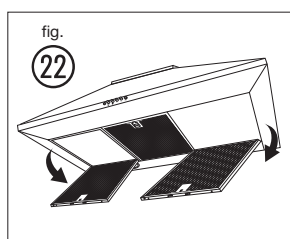
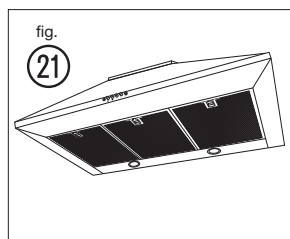

### Technical data

Power supply	:	120V~, 60Hz
Power consumption	:	520W
Bulb type	:	2x 20W, 120V~ (type: GU10)
Power cable type	:	18AWG (Amer. Wire Gauge) 300V~, 105°C

## Troubleshooting

Problem	Cause	Solution
Excessive vibration.	The appliance is not fixed properly on the brackets.	Take down the appliance and check it is properly fixed.
	The fan blade is damaged.	Switch off the appliance. Repair to be carried out by qualified service personnel only.
	The fan motor is not fixed tightly.	
Light on, but fan does not work.	The fan blade is jammed.	Switch off the appliance. Repair to be carried out by qualified service personnel only.
	The motor is damaged.	
Both light and fan do not work.	Light bulb broken.	Replace with a bulb with correct rating.
	Problem with electrical connection	Check the electrical connection with an electrician.
Suction performance is not good.	Distance between the appliance and the cooking place too large.	Readjust the distance (page 7, fig. 5 and table below)
	Metallic anti-grease filter is dirty.	Clean filters (see <i>Cleaning and maintenance</i> ).

## Environmental protection



Waste electrical products should not be disposed of with household waste. Please recycle where facilities exist. Check with your Local Authority or retailer for recycling advice.

## Warranty information

Your appliance is covered by a one year limited warranty. For one year from your original date of purchase, Electrolux will pay all costs for repairing or replacing any parts of this appliance that prove to be defective in materials or workmanship when such appliance is installed, used and maintained in accordance with the provided instructions.

### Exclusions

This warranty does not cover the following:

1. Products with original serial numbers that have been removed, altered or cannot be readily determined.
2. Product that has been transferred from its original owner to another party or removed outside the USA or Canada.
3. Rust on the interior or exterior of the unit.
4. Products purchased "as-is" are not covered by this warranty.
5. Food loss due to any refrigerator or freezer failures.
6. Products used in a commercial setting.
7. Service calls which do not involve malfunction or defects in materials or workmanship, or for appliances not in ordinary household use or used other than in accordance with the provided instructions.
8. Service calls to correct the installation of your appliance or to instruct you how to use your appliance.
9. Expenses for making the appliance accessible for servicing, such as removal of trim, cupboards, shelves, etc., which are not a part of the appliance when it is shipped from the factory.
10. Service calls to repair or replace appliance light bulbs, air filters, water filters, other consumables, or knobs, handles, or other cosmetic parts.
11. Surcharges including, but not limited to, any after hour, weekend, or holiday service calls, tolls, ferry trip charges, or mileage expense for service calls to remote areas, including the state of Alaska.
12. Damages to the finish of appliance or home incurred during installation, including but not limited to floors, cabinets, walls, etc.
13. Damages caused by: services performed by unauthorized service companies; use of parts other than genuine Electrolux parts or parts obtained from persons other than authorized service companies; or external causes such as abuse, misuse, inadequate power supply, accidents, fires, or acts of God.

USA  
 1.800.944.9044  
 Electrolux Major Appliances  
 North America  
 10200 David Taylor Drive  
 Charlotte, NC 28262



Canada  
 1.800.265.8352  
 Electrolux Canada Corp.  
 5855 Terry Fox Way  
 Mississauga, Ontario, Canada  
 L5V 3E4

## DISCLAIMER OF IMPLIED WARRANTIES;

### LIMITATION OF REMEDIES

CUSTOMER'S SOLE AND EXCLUSIVE REMEDY UNDER THIS LIMITED WARRANTY SHALL BE PRODUCT REPAIR OR REPLACEMENT AS PROVIDED HEREIN. CLAIMS BASED ON IMPLIED WARRANTIES, INCLUDING WARRANTIES OF MERCHANTABILITY OR FITNESS FOR A PARTICULAR PURPOSE, ARE LIMITED TO ONE YEAR OR THE SHORTEST PERIOD ALLOWED BY LAW, BUT NOT LESS THAN ONE YEAR. ELECTROLUX SHALL NOT BE LIABLE FOR CONSEQUENTIAL OR INCIDENTAL DAMAGES SUCH AS PROPERTY DAMAGE AND INCIDENTAL EXPENSES RESULTING FROM ANY BREACH OF THIS WRITTEN LIMITED WARRANTY OR ANY IMPLIED WARRANTY. SOME STATES AND PROVINCES DO NOT ALLOW THE EXCLUSION OR LIMITATION OF INCIDENTAL OR CONSEQUENTIAL DAMAGES, OR LIMITATIONS ON THE DURATION OF IMPLIED WARRANTIES, SO THESE LIMITATIONS OR EXCLUSIONS MAY NOT APPLY TO YOU. THIS WRITTEN WARRANTY GIVES YOU SPECIFIC LEGAL RIGHTS. YOU MAY ALSO HAVE OTHER RIGHTS THAT VARY FROM STATE TO STATE.

### If You Need Service

Keep your receipt, delivery slip, or some other appropriate payment record to establish the warranty period should service be required. If service is performed, it is in your best interest to obtain and keep all receipts. Service under this warranty must be obtained by contacting Electrolux at the addresses or phone numbers below.

This warranty only applies in the USA and Canada. In the USA, your appliance is warranted by Electrolux Major Appliances North America, a division of Electrolux Home Products, Inc. In Canada, your appliance is warranted by Electrolux Canada Corp.

Electrolux authorizes no person to change or add to any obligations under this warranty. Obligations for service and parts under this warranty must be performed by Electrolux or an authorized service company. Product features or specifications as described or illustrated are subject to change without notice.

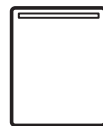

# DISHWASHER

## *use & care*

Introduction.....	2	Operating Instructions.....	8
Important Safety information.....	3	Care and Cleaning .....	10
Features.....	5	Troubleshooting.....	17
Controls and settings .....	6	Limited Warranty .....	20
Operating Instructions .....	8		

# 2

## INTRODUCTION

### Welcome to our family

Thank you for bringing Frigidaire into your home! We see your purchase as the beginning of a long relationship together.

This manual is your resource for the use and care of your product. Please read it before using your appliance. Keep it handy for quick reference. If something doesn't seem right, the troubleshooting section will help you with common issues.

FAQs, helpful tips and videos, cleaning products, and kitchen and home accessories are available at [www.frigidaire.com](http://www.frigidaire.com).

We are here for you! Visit our website, chat with an agent, or call us if you need help. We may be able to help you avoid a service visit. If you do need service, we can get that started for you.

Let's make it official! Be sure to register your product.

Keep your product info here so it's easy to find.

Model Number \_\_\_\_\_

Serial Number \_\_\_\_\_

Purchase Date \_\_\_\_\_



#### NOTE

The dishwasher is programmed to remember your last cycle so you do not have to reset each time. To start the dishwasher using the same cycle and options selected on the previous wash, just press the START pad.



#### NOTE

Not all cycles and options available on all models.



#### NOTE

The filters will need to be cleaned to maximize wash performance during the life of your dishwasher. See "Recommended Frequency to Clean Your Filters" for a cleaning schedule.



#### NOTE

**Very Important Information - Read Before Operating Your Dishwasher!**

**Normal Operating Sounds**

This dishwasher does not sound like most dishwashers - IT'S QUIETER.

Your Direct Feed Wash System dishwasher uses energy efficient motors for the wash and drain portions of the cycle you select. Each cycle has a series of water fills and drains for washing and rinsing dishes. As each cycle begins, you may-or may not- hear the drain motor. The next sound you will hear is the splashing water as it enters the tub.

**PLEASE BE ADVISED:** If you compare this dishwasher to previous models, you may be surprised at what you DON'T hear.



#### NOTE

**Why Energy Efficient Units run long cycles:** Several factors are important to washing dishware. The energy use of the dishwasher was reduced by applying more of the factors that don't use so much energy and less of the ones that use more. As a result, you will see that the wash cycles take longer.





## WARNING

Please read all instructions before using this dishwasher.

### For your Safety

- Use your dishwasher only as instructed in this User Manual.
  - This Manual does not cover every possible condition and situation that may occur. Use common sense and caution when installing, operating and maintaining any appliance.
  - NSF certified residential dishwashers are not intended for licensed food establishments.
  - **DISHWASHER MUST BE ELECTRICALLY GROUNDED.** Read the Installation Instructions for details.
  - This dishwasher is designed to operate on regular house current (120V, 60Hz). Use a circuit equipped with a 15 ampere fuse or circuit breaker. Use a 20 ampere fuse if dishwasher is connected with a food disposer.
  - Do not operate dishwasher unless all enclosure panels are in their proper place.
  - To avoid entrapment and/or suffocation, remove door or door latch mechanism from any dishwasher that is discarded or not in use.
  - Keep young children and infants away from dishwasher when it is operating.
  - Do not let children abuse, sit, stand or play on door or racks of a dishwasher.
  - Use only detergents and rinse agents recommended for use in a dishwasher.
  - Store dishwasher detergent and rinse agents out of the reach of children.
  - Do not wash plastic items unless marked: "Dishwasher Safe" or equivalent. Check with manufacturer for recommendations, if not marked. Items that are not marked dishwasher safe may melt and create a potential fire hazard.
  - Disconnect electrical power to dishwasher before servicing.
  - If the dishwasher drains into a food disposer, make sure disposer is completely empty before running dishwasher.
- Repairs should be done by a qualified technician.
  - Do not tamper with controls.
  - Do not touch the heating element during or immediately after
  - Use care unloading the dishwasher when the Sanitize option has been selected. Contents may be hot to the touch immediately after the end of cycle.
  - Water vapor from the vent may be hot to the touch when the Sanitize option has been selected. Use care and do not let small children play around or touch the vent area of the dishwasher.
  - When loading items to be washed:
    - Locate sharp items and knives so that they are not likely to damage the door seal or tub.
    - Load sharp items and knives with the handles up to reduce the risk of cut-type injuries.
  - Under certain conditions, hydrogen gas may be produced in a hot water, system that has not been used for 2 weeks or more. **HYDROGEN GAS IS EXPLOSIVE.** If hot water system has not been used for such a period, before using dishwasher, turn on for several minutes This will release any accumulated hydrogen gas. **HYDROGEN GAS IS FLAMMABLE.** Do no smoke or use an open flame during this time.
  - Do not store or use combustible materials, gasoline or other flammable vapors and liquids in the vicinity of this or any other appliance.



## WARNING

To reduce the risk of fire, electrical shock or injury when using your dishwasher, follow the above basic precautions.



## WARNING

This symbol will help alert you to such dangers as personal injury, burns, fire and electrical shock.

# 4

## IMPORTANT SAFETY INFORMATION

---



### WARNING

To reduce the risk of fire, electrical shock or injury when using your dishwasher, follow the previous basic precautions .



### WARNING

Please read all instructions before using this appliance.

### Safety Definitions

 This is the safety alert symbol. It is used to alert of potential personal injury hazards. Obey all safety messages that follow this symbol to avoid possible injury or death.



### DANGER

DANGER indicates an imminently hazardous situation which, if not avoided, will result in death or serious injury.



### WARNING

WARNING indicates a potentially hazardous situation which, if not avoided, could result in death or serious injury.



### CAUTION

CAUTION indicates a potentially hazardous situation which, if not avoided, may result in minor or moderate injury.



### IMPORTANT

IMPORTANT indicates installation, operation or maintenance information which is important but not hazard-related.

### Child Safety

Destroy or recycle the carton, plastic bags, and any exterior wrapping material immediately after the dishwasher is unpacked. Children should **NEVER** use these items to play. Cartons covered with rugs, bedspreads, plastic sheets or stretch wrap may become airtight chambers, and can quickly cause suffocation.

### Safety Instructions

- DO NOT store or use gasoline, or other flammable liquids in the vicinity of this or any other appliance. Read product labels for warnings regarding flammability and other hazards.
- Remove all staples from the carton. Staples can cause severe cuts, and also destroy finishes if they come in contact with other appliances or furniture.

### SAVE THESE INSTRUCTIONS

Your dishwasher cleans by spraying a mixture of hot water and detergent through the spray arms against soiled surfaces. First, the dishwasher fills with water covering the filter area. Water is then pumped through the spray arms. Soil particles go across the filter and down the drain as the water is pumped out. This series of steps are repeated as needed. The number of water fills vary with the cycle being used.

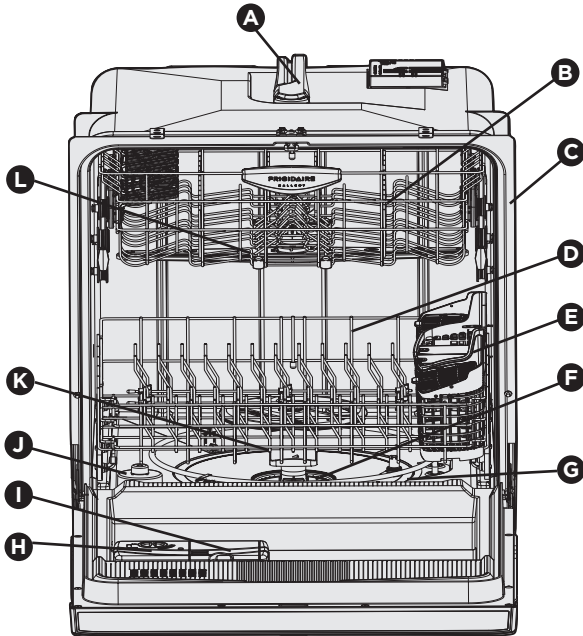

Features may vary according to model

<b>A</b>	Nozzle or Spray Arm (located inside the unit)
<b>B</b>	Top Rack
<b>C</b>	Serial Label (Located on Right)
<b>D</b>	Lower Rack
<b>E</b>	Silverware Basket
<b>F</b>	Glass Trap

<b>G</b>	Heating Element
<b>H</b>	Rinse Aid Compartment
<b>I</b>	Detergent Dispenser
<b>J</b>	Overfill Protector
<b>K</b>	Lower Spray Arm
<b>L</b>	Middle Spray Arm



## IMPORTANT

Accessories are available for your appliance and may be purchased at [Frigidaire.com](http://Frigidaire.com) or by calling 1-800-374-4432 (Frigidaire.ca or 1-800-265-8352 in Canada) or from an authorized seller.

# 6

## CONTROLS AND SETTINGS

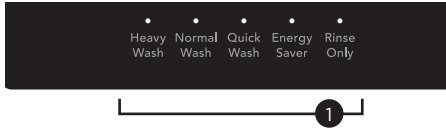

**NOTE**

Your dishwasher uses a DishSense™ Technology to understand how much food is on the dishes and then adjusts the cycle accordingly.



**CAUTION**

**Property Damage Hazard**

Before starting dishwasher be sure that the water is connected and turned on. Failure to do so may cause damage to the pump seal and result in water leakage.

**NOTE**

Lights on the console will remain on once the door is shut and wash cycle begins. If it is preferred to have the lights turn off while cycle is running see Console Lights section for instructions.

### Recommended Cycle for typical use:

The **Normal Wash** cycle with its factory default options of normal temperature and heated dry together provide the best all around performance. This cycle selection is recommended for everyday use and is suitable for a large range of both dish load sizes and food quantities remaining on those dishes.

### Wash Cycle Selections

- 1 Cycle times are approximate and will vary with options selected. Hot water is necessary to activate dishwasher detergent and melt fatty food soils. An automatic sensor will check the incoming water temperature and, if it is not hot enough, the cycle will be lengthened for automatic water heating in the main wash and final rinse of all cycles. This happens even when **High Wash Temp** option has not been selected. When **High Wash Temp** is selected, an even higher temperature will be reached to handle heavier soil loads.
- 2 **START/Cancel Button**  
When cycle and options are selected, LEDs of selected cycle and options are illuminated. To start the cycle, press the **START/Cancel** button and immediately close the dishwasher door.  
  
Press and hold the **Cancel** button for 3 seconds if you have selected your cycle and options and decide to cancel. The unit will go into stand-by mode, which all LEDs will go out. You can cancel a cycle anytime during the cycle. Press and hold the **START/Cancel** pad for 3 seconds. The light above the cycle and option selected will go out, and the **START/Cancel** light will remain illuminated, the dishwasher will start a 90 second drain. At the end of the drain, select the next desired cycle.

**3 Status Indicator Lights**

The console lights provide information about the cycle selection and current status. During operation, while the door is closed, these lights will remain on. At the completion of the cycle, the clean light will come on. The sanitization light will also come on if that option was selected and sanitization was achieved during the wash cycle.

**Floor Light Beam****Green Light**

The GREEN LIGHT illuminates on the floor when the wash is complete.

**Blue Light**

The BLUE LIGHT illuminates on the floor to indicate that the wash cycle is operating.

**Option Selections****4 Wash Temp**

The programmed cycles default to the **Normal** temperature option, to choose **High** or **Sanitize** press **Wash Temp** pad.

**Sanitize Option**

To sanitize your dishes and glassware, select the **Sanitize** option. When selected, the indicator light will come on and remain on until the end of cycle. The water temperature in the final rinse will be raised to 156° F (69° C). This option is available in **Heavy Wash**, and **Normal Wash** Cycles. Only these sanitization cycles have been designed to meet NSF requirements.

The cycle time will be extended until the proper water temperature is reached. Washing action will continue during the water heating delay. For best results, the incoming water temperature should be at least 120° F (49° C).

The sanitize criteria may not be satisfied if there is an interruption of the cycle, power failure or if the incoming water temperature is below 120° F (49° C).

To turn off the **Sanitize** option, press **Wash Temp** until the desired temperature option is selected. The indicator light will turn off.

**High Wash Temp Option**

When **High Wash Temp** option is selected, the dishwasher heats water in the main wash to approximately 140° F (60° C).

This increase in water temperature helps the dishwasher detergent remove food grease and soil from dishes more effectively and aids in drying. **High Wash Temp** option is available on **Heavy Wash**, and **Normal Wash** cycles. **High Wash Temp** is automatically provided when the **Heavy Wash** cycle is selected.

When High Wash Temp option is selected, the indicator light will come on and remain on until end of cycle. To turn off the **High Wash Temp** option, **Wash Temp** until the desired temperature option is selected. The indicator light will turn off.

**5 Dry Options**

The programmed cycles default to the Heat temperature option, to choose **MaxBoost™**, **Heat** or **Air**, press the Dry pad.

**MaxBoost™**

When **MaxBoost™** option is selected, the dishwasher extends drying time by approximately 20 minutes. The **MaxBoost™** option can be used with all cycles except **China Crystal**, **Energy Saver** and **Rinse Only**. For best drying performance, also apply an increased wash temperature by selecting **High Wash Temp** or even better, the **Sanitize** option.

The energy required to use the **MaxBoost™** option costs pennies per cycle. You may choose not to select the **MaxBoost™** option; however you may have items in your dish load that will not be completely dry at the end of the cycle.

**Heat Dry/Air Dry**

Use of the **Heat Dry** option, especially in combination with use of rinse agent, will enhance drying. If **Air Dry** is selected the heater will be deactivated during the drying phase of the selected wash cycle. This will slightly lower the energy use but will increase the likelihood that the dishware will not dry completely.

# 8

## OPERATING INSTRUCTIONS

---

### 6 Delay Time

The **Delay Time** option allows you to automatically delay starting your dishwasher 2, 4, or 6 hours.

To start the **Delay Time** option, press **Delay Time** until the desired delay time LED illuminates. A light will come on indicating the delay has been set and will remain on until cycle starts. Press the **START/Cancel** button to start the delay option. If the delay option is interrupted, the **START/Cancel** button will have to be pressed again to return to delay option.

To cancel the **Delay Time** option and **to begin the selected cycle before the delay period is over**, press and hold **START/Cancel button for 3 seconds**.

### 7 Control Lock

Lock the dishwasher controls by pressing and holding the **Control Lock** button until the lock LED comes on to prevent children from starting the dishwasher or accidentally changing the wash cycle. To unlock the controls, press the **Control Lock** button until the lock LED goes off.

## Operating Instructions

### Getting Started

1. Load Dishwasher (See Preparing and Loading Dishes).
2. Add detergent (See Dishwasher Dispenser & Detergents).
3. Add Rinse Aid, if needed (See Rinse Aid).
4. Run hot water faucet nearest dishwasher until water is hot. Turn water off.
5. Select desired **Cycle** (See Cycle Chart).
6. Select desired **Option** (See Option Selections).
7. To start, press **START/Cancel** pad and close door immediately.

### To Start a Cycle

When cycle and options are selected, LEDs of selected cycle and options are illuminated, and the LED above the **START/Cancel** button illuminates.

To start the cycle, press **START/Cancel** button and immediately close the dishwasher door.

### To Cancel a Cycle and Delay Cycle

Both a running cycle and a delay cycle can be canceled at any time.

Open the dishwasher door and press the **START/Cancel** button until the cycle and option LEDs turn off. The running cycle or delay countdown is canceled.

Press the **START/Cancel** button and close the door immediately to drain. After a 90 second drain you may be able to select a new cycle after canceling a previous wash cycle.

### Opening the door during cycle

If you open the door while a cycle is running or delay is counting down, the dishwasher will stop running.

The LEDs of selected cycle and options are illuminated. The LED above **START/Cancel** button will blink to press start.

To resume, press **START/Cancel** button and close the dishwasher door immediately.

The **START/Cancel** LED illuminates solid after the **START/Cancel** button is pressed.

If the dishwasher door is kept open for too long, or the door is closed without pressing **START/Cancel** button, the running cycle or delay countdown will be canceled.

### Console Lights

If it is desired to have the console lights remain off while running, perform the following operation: Prior to starting a cycle, press and hold **Heavy Wash** and **Rinse Only** simultaneously for approximately 8 seconds until the corresponding lights flash. This will turn the console lights off during cycle operation. Simply repeat this operation to revert back to the previous setting.

The DishSense™ Technology checks the soil level on your dishes in the **Heavy Wash**, **Normal Wash**, and **Energy Saver cycles**. In response, automatic cycle adjustments are made to assure the dishware gets clean - with less food the cycle gets shorter. Cycle time will also vary based on the options selected and the incoming water temperature. **Not all cycles available on all models.**

## Cycle and Option Chart

Cycle	Available Options	Water (approx.)	Time *(Hours)
<b>Heavy Wash*</b> Recommended for pots, pans, casseroles and dinnerware having light to heavily soiled loads.	<b>Temperature:</b> Sanitize, High <b>Drying:</b> MaxBoost™, Heat, Air	7.1 - 9.4 gal. 27 - 36 L.	2 ¼ - 4
<b>Normal Wash*</b> Recommended for lightly to heavily soiled loads.	<b>Temperature:</b> Sanitize, High, Normal <b>Drying:</b> MaxBoost™, Heat, Air	3.2 - 9.2 gal. 12 - 35 L.	1 ¼ - 4
<b>Quick Wash</b> Recommended for lightly soiled loads only.	<b>Temperature:</b> Normal <b>Drying:</b> MaxBoost™, Heat, Air	5.4 gal. 20 L.	34 min. (Air Dry Only)
<b>Energy Saver*</b> Recommended for lightly soiled loads.	<b>Temperature:</b> Normal <b>Drying:</b> Air	4.8 - 5.8 gal. 18 - 22 L.	1 ½ - 2
<b>Rinse Only</b> For rinsing dishware that will be washed later.	<b>Default:</b> Surge <b>Options:</b> None Available	2.5 gal. 9 L.	¼ (Air Dry Only)

\* Cycle uses Soil Sensing feature to determine best Wash performance.

# 10 CARE AND CLEANING

## Dish Preparation

Scrape away large pieces of food, bones, pits, toothpicks, etc. The continuously filtered wash fluid will remove remaining food particles. Burned-on foods should be loosened before loading. Empty liquids from glasses and cups.

Foods such as mustard, mayonnaise, vinegar, lemon juice and tomato based products may cause discoloration of stainless steel and plastics if allowed to sit for a long period of time. Unless the dishwasher is to be operated at once, it is best to pre-rinse or use the **Rinse Only** cycle to rinse off these food soils.

- Load racks so that large items do not prevent the detergent dispenser from opening.
- Check manufacturer's recommendations before washing items in question.
- If the dishwasher drains into a Food Disposer, **be sure disposer is completely empty before starting dishwasher.**

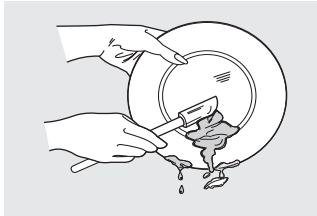

## Loading the Top Rack

**Features and appearance of racks and silverware basket as shown may vary from your model.**

The upper rack is designed for flexibility in loading a wide variety of items including cups, glasses, stemware, small plates, bowls, etc.

Load glasses in top rack only. Damage may occur if placed in bottom rack.

Load plastic items in top rack only. Melting may occur if placed in bottom rack.

Load items with open ends facing down for better cleaning and draining.

Damage may occur if delicate items touch each other during dishwasher operation.

Long-handled knives and utensils can be placed in top rack.

Be sure nothing protrudes through the bottom of the rack to block rotation of middle spray arm.

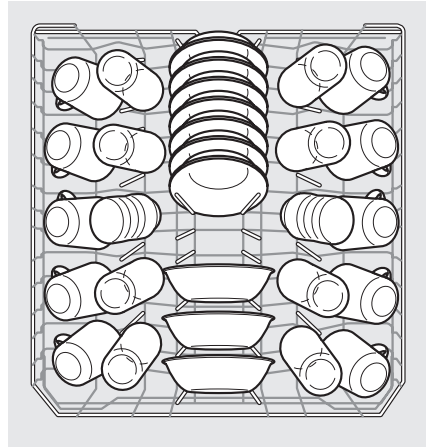

10 place settings standard loading pattern

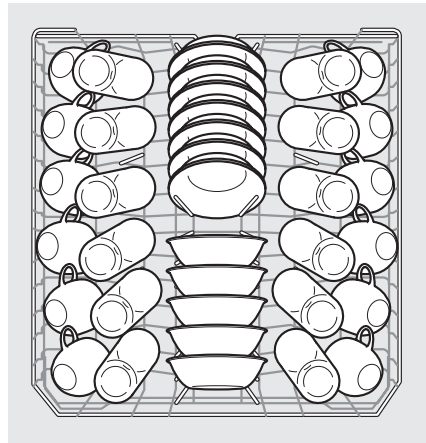

12 place settings standard loading pattern



## Upper Rack

The **Upper Rack** cycle directs cleaning only to items in the upper rack and can be used to wash a wide assortment of items. It is useful for washing partial loads - especially when the upper rack fills up with glasses and the lower rack is still empty.

**STEMWARE HOLDER/CUP SHELF not available on all models.**

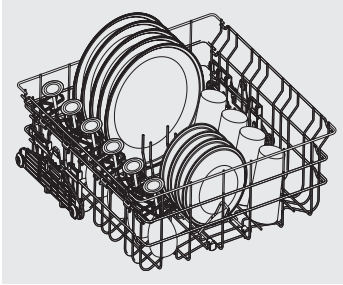

## Adjustable Upper Rack

To raise the upper rack, refer to the figure below. Press the lever toward the center of the rack and pull straight up on the rack.

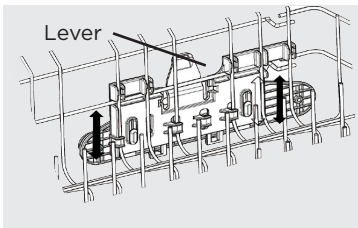

To lower the upper rack, press the lever and push down on the rack.

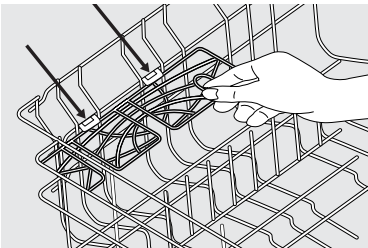

Place the clips of the cup shelf over the horizontal rack wires and push down to attach the cup shelf onto the second wire of the upper rack.

## Loading the Bottom Rack

**Features and appearance of racks and silverware basket as shown may vary from your model.**

The lower rack is best for plates, saucers, bowls, and cookware. Large items should be placed along the edge so they do not block the spray arm rotation. For best results, place bowls, casseroles, and sauce pans with soiled surface facing down and toward the center. Tilt slightly for better drainage.

Spin the middle spray arm to make sure that tall items do not block the rotation

Be sure pan handles do not protrude through the bottom of the rack and block the lower spray arm rotation.

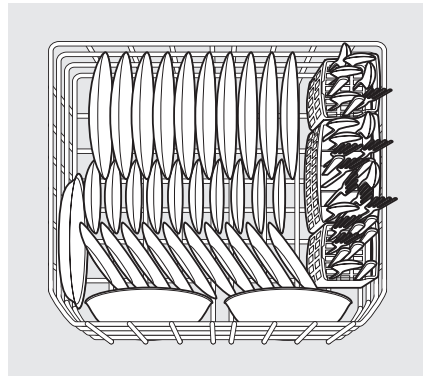

10 place settings standard loading pattern.

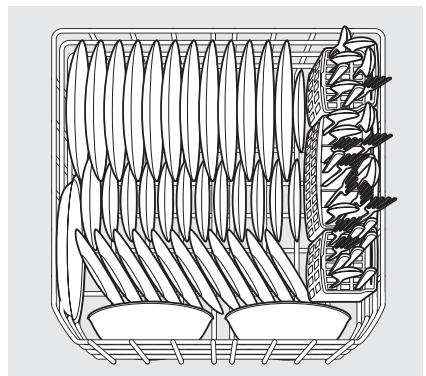

12 place settings standard loading pattern

# 12 CARE AND CLEANING

## Loading the Silverware Basket



### CAUTION

Load sharp items (knives, skewers, etc.) pointing down.

Failure to do so may result in injury.

### Features and appearance of racks and silverware basket as shown may vary from your model.

Load the silverware basket while it is in the bottom rack or take the basket out for loading on a counter or table.

For baskets with lids, small items like baby bottle caps, jar lids, corn cob holders, etc., can be placed in a covered section to hold them in place.

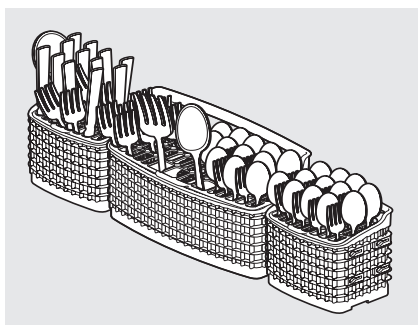

Use suggested loading patterns, as shown, to increase washability of the silverware.

Be sure nothing protrudes through bottom of basket or rack to block the spray arm.

To avoid damaging the silver finish do not mix silver and stainless.

When covers are up, mix items in each section of the basket with some pointing up and some down to avoid nesting. Water spray cannot reach nested items.

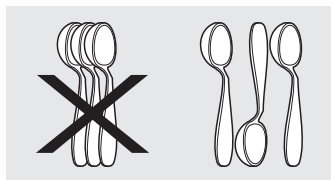

## Adding a Dish

To add or remove items after wash cycle starts:

- Unlatch door and wait a few seconds until wash action stops before opening.
- Add the item, move the door to a near-closed position, and wait a few seconds while the cold air slowly expands inside the dishwasher.
- Press the **START/Cancel** button then close the door firmly within 4 seconds to resume.



### WARNING

Open the door very slowly & carefully if the dishwasher is operating. There is a risk of hot water squirting out.

## Filling the Detergent Dispenser

The detergent dispenser has two detergent cups. The smaller one is for addition to the pre-wash and the larger is for release to the main wash.

- Use only fresh automatic dishwashing detergent. Other detergents may cause oversudsing.
- When using automatic dishwashing detergent tablets or packets, use only one tablet or packet, place in the main wash cup and close.
- Add detergent just before starting cycle.
- Store detergent in a cool, dry location and discard any that becomes moist or caked.

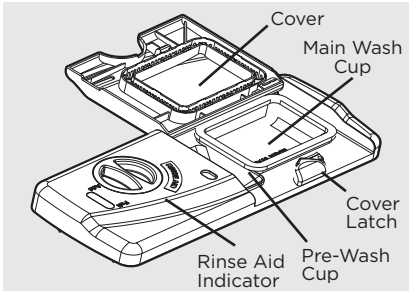

If the cover is closed on the Main Wash Cup open by pressing the Cover Latch.

## How much Detergent to use

The amount of detergent to use depends on the water hardness. Water hardness is measured in grains per gallon. Using too little detergent can result in poor cleaning and hard water filming or spotting. Using too much detergent in soft water can cause etching to some glassware which is surface damage that appears like a film but cannot be wiped off. Your local water company, water softener company or county extension agent can tell you the water hardness in your area.



## CAUTION

The use of industrial grade detergent can damage the heating coil and other parts of the dishwasher leading to damage to the unit and surrounding property. Use only household grade automatic dishwasher detergents.

## Detergent Usage Chart

Cycle	Soft Water (0-3 grains)	Medium Hard Water (4-8 grains)	Hard Water (9-12 grains)	Very Hard Water (Over 12 grains)
Heavy Wash or Normal Wash	2 teaspoons (each cup: $\frac{1}{4}$ full)	5 teaspoons (each cup- fill to line above "Regular")	8 teaspoons (each cup- completely full)	Each Cup- Completely Full (water softener recommended)
Top Rack, Quick Wash, China Crystal or Energy Saver	2 teaspoons (Main Wash cup: $\frac{1}{4}$ full)	5 teaspoons (each cup- fill to line above "Regular")	8 teaspoons (Main Wash cup- completely full)	Main Wash Cup- Completely Full (water softener recommended)
Rinse Only	No Detergent	No Detergent	No Detergent	No Detergent (water softener recommended)

As a rule, use 1 teaspoon for each grain above 12. For very hard water, detergent alone may not be enough and then a water softener is recommended to improve water quality and dishwashing performance. However, when - using automatic dishwashing detergent tablets or packets simply place one in the main wash cup.

# 14 CARE AND CLEANING

## Rinse Aid

**Rinse aid greatly improves drying and reduces water spots.** With it water “sheets” off dishes rather than forming water droplets that cling and leave spots.

A dispenser, located next to the detergent cup, automatically releases a measured amount of rinse aid during the last rinse. If spotting and poor drying are problems, increase the amount of rinse aid dispensed by rotating the dial to a higher number. The dial is located under the dispenser cap. The indicator will be dark when full and will show clear when it is time to refill.

To add liquid rinse aid, turn dispense cap 1/4 turn counterclockwise and lift out. Pour in rinse aid until liquid touches the indicated fill level. Replace cap.

Do not overfill since this can cause oversudsing. Wipe up any spills with a damp cloth.

The dispenser holds enough for 35 to 140 washes, depending on the dial setting.

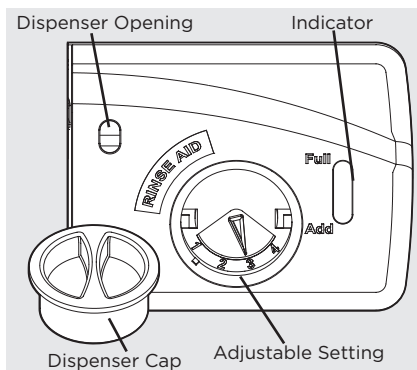

## Water Pressure

The hot water line to dishwasher must provide water pressure between 20 and 120 psi.

Low Water pressure may occur when laundry or showers are in operation. If you experience poor wash performance you may need to wait until water use is reduced before starting dishwasher.

## Water Temperature

Hot water is needed for best dishwashing and drying results. Water entering dishwasher should be at least 120° F (49° C) to give satisfactory results.

To check water temperature entering dishwasher:

- Turn on hot water faucet nearest dishwasher for several minutes to clear cool water from pipes.
- Hold a candy or meat thermometer in the water stream to check the temperature.
- If temperature is below 120° F (49° C), have a qualified person raise the hot water heater thermostat setting.



## IMPORTANT

Before starting a cycle, run hot water to clear cool water from pipe.

The **Heat Dry** option in combination with rinse aid will enhance drying performance. The energy required to use the **Heat Dry** option costs pennies per cycle. You may choose not to select the **Heat Dry** option; however you will have items in your dish load that will not be completely dry at the end of the cycle.

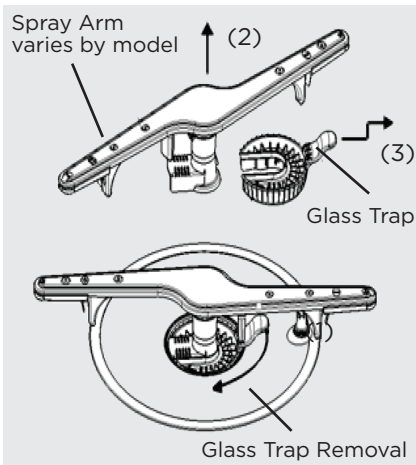

### To empty the glass trap:

1. Grasp the glass trap's handle and rotate it 90° clockwise while pressing down on the center of the wash arm.
2. Grab the spray arm in the center and lift the spray arm and glass trap assembly up and out from the dishwasher.
3. Tip the assembly over an appropriate container and tap it to empty the glass trap OR, separate the glass trap - pull the glass trap handle toward you, then up, then further toward you to slide it away from the rest of the assembly; empty it into an appropriate container; then slide the glass trap back into the assembly.
4. Place the assembly back into position, press down on the arm at the center and rotate the glass trap handle 90° counterclockwise being sure the glass trap ends in the orientation shown in the image above. To avoid damage to your unit make sure the spray arm and glass trap are fully snapped in place.



### WARNING



#### Burn Hazard

Allow heating element to cool before cleaning the interior.

Failure to do so can result in burns.

**Outer Door** - Clean outer door with warm soapy water and a dishcloth or sponge. Rinse with clean water and a dry cloth. Do not use harsh cleaners.

**Inside** - The inside of the dishwasher and filter are self-cleaning with normal use. If needed, clean around the tub gasket area with a damp cloth. The filter is self-cleaning. A glass trap located in the center of the filter is designed to collect pieces of broken glass, straws, bones and pits.

**Overflow Protector**- keeps dishwasher from overflowing and is located in the left front corner of the tub.

- Clean occasionally with household cleaner containing vinegar or bleach to dissolve any buildup.
- Overflow Protector should move up and down freely about one inch. If it does not move, lift and clean underneath.

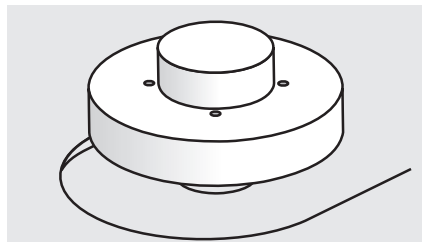

### NOTE

Hard water may cause lime deposit buildup on the interior of the dishwasher. For cleaning instructions see "Removing Spots and film" section.

# 16 CARE AND CLEANING

---

## Care of Drain Air Gap

If a drain air gap was installed for your built-in dishwasher, check to make sure it is clean so the dishwasher will drain properly. A drain air gap is usually mounted on countertop and can be inspected by removing the cover. This is not part of your dishwasher and is not covered by warranty.



### CAUTION

#### Property Damage Hazard

Freezing temperatures may cause water lines to rupture. Be sure all supply lines to and circulating lines within dishwasher are protected.

Failure to do so could result in property damage.



### NOTE

See Installation Instructions for more details on disconnecting and restoring service to your dishwasher.

## Winterizing

A dishwasher left in an unheated place should be protected from freezing. Have a qualified person do the following:

### To Disconnect Service:

1. Turn off electrical power to the dishwasher at the supply source by removing fuses or tripping circuit breaker.
2. Shut off water supply
3. Place a pan under the inlet valve. Disconnect water line from inlet valve and drain into pan.
4. Disconnect drain line from pump and drain water into pan.

### To Restore Service:

1. Direct water line discharge into a pan and open the valve to flush the line.
2. Reconnect the water, drain, and electrical power supply.
3. Turn on water and electrical power supply.
4. Fill both detergent cups and run dishwasher through a **Heavy Wash** cycle.
5. Check connections to make sure they do not leak.

Before calling for service, review this list. It may save you both time and expense. This list includes common experiences that are not the result of defective workmanship or material in your dishwasher.

### Food Soils Left on Dishes

- Choose another cycle for longer washing time.
- Check rack loading section for proper loading-avoid nesting items.
- Home water pressure may be too low-should be 20 to 120 pounds per square inch (psi).
- Check incoming water temperature. It should be about 120° F (49° C). (See Factors Affecting Performance.)
- Check water hardness. For extremely hard water, it may be necessary to install a water softener. (See Detergent Chart).
- Use Fresh Detergent.
- Make sure items are not blocking the spray arms, preventing them from rotating.
- Do not overload the dishwasher (See Preparing and Loading Dishes).
- Check to verify that the glass trap is maintained and installed properly (See Care and Cleaning).

### Dishes not Dry

- Select heat or MaxBoost™ option.
- Make sure the rinse aid dispenser is filled.
- Increase the discharge setting of rinse aid. (See Rinse Aid).
- Check the incoming water temperature. Be sure it is at least 120° F (49° C).
- Check for proper loading-avoid nesting items.
- Cups with a concave bottom will collect water. Load them at the far left and right of the upper rack so they will be held in a tilted position.
- Containers, bowls, pots/pans, and

any dishware with concave surfaces that can collect water should be placed in the rack facing or angled down so that water is able to drain even from the lowest point.

- Plastic items may need to be towel dried.

### Glassware/Flatware Spotted or Cloudy

- Check water hardness. For extremely hard water, it may be necessary to install a water softener. (See Detergent Chart).
- Water temperature may be low. Avoid extremely low or high temperatures. (See Factors Affecting Performance).
- Avoid overloading and improper loading. (See Preparing and Loading Dishes).
- Use fresh detergent. Old detergent is ineffective.
- Make sure rinse aid dispenser is filled.
- Check to see that proper amount of detergent is being used for cycle selected. (See Detergent Dispenser).
- Home water pressure may be too low-it should be 20 to 120 pounds per square inch (psi).

### Dishware Chipped

- Load with care and do not overload. (See Preparing and Loading Dishes).
- Place delicate items in top rack.
- Place glasses securely against pins and not over pins.
- Load items so they are secure and don't jar loose when moving racks in and out. Move racks in and out slowly.
- Make sure tall glasses and stemware will clear top of tub when rack is pushed in.
- Fine antique china and crystal should be hand-washed.

# 18 TROUBLESHOOTING

---

## Vapor at Vent

- Spilled rinse aid can cause foam and lead to overflowing. Wipe up any spills with a damp cloth.

## Dishware Stained or Discolored

- Tea and coffee can stain cups. Remove the stains by hand washing in a solution of 1/2 cup (120 ml) bleach and one quart (1L) of warm water. Rinse thoroughly.
- Iron deposits in water can cause a yellow or brown film. A special filter installed in the water supply line will correct this problem. **(See Removing Spots and Film).**
- Aluminum utensils can leave gray/black marks when they rub against other items. Load Properly.
- Certain high acid foods can cause discoloration of stainless steel and plastics if allowed to sit for a long period. Use the Rinse Only cycle or rinse by hand if not operating dishwasher at once.
- Mixing stainless steel and silver utensils in silverware basket can cause pitting of the stainless steel blades. Avoid mixing stainless steel and silver.

## Water in Bottom of Tub

- Water left in the tub bottom after the cycle is complete is not normal. If water remains in the bottom of the tub, the dishwasher may not be draining properly. **(See Dishwasher Does not Drain Properly).**

## Cycle Takes a Long Time

- The cycle may have been automatically lengthened to reach key temperatures due to some factor such as a cool water supply or a large load of dishes.
- Delay Start option may have been selected.
- Choose lower temperature options to shorten the cycle.
- Cycles that are soil-sensing adjust automatically to assure a good wash - heavier soils will elicit a longer cycle response.

## Etching

- Using too much detergent especially in soft or softened water causes damage that looks like a film but cannot be removed.
- Adjust the amount of detergent based on the water hardness. **(Check Detergent Chart).**
- Lower the water temperature by selecting one of the lower temperature options.

## Detergent Left in Cups

- Detergent may be old. Discard and use fresh detergent.
- Be sure the dish load doesn't block spray from entering the detergent cup.
- Check to see if cycle has been completed.
- Make sure items do not prevent the detergent dispenser from opening.

## Dishwasher Leaks

- Check that the door gasket is pressed into its mounting channel, reaches to the bottom of the tub and does not extend beyond the end rib so as to interfere with door closure.
- Spilled rinse aide can cause foam and lead to overflowing. Wipe up any spills with a damp cloth.
- Check to see that the dishwasher is level. (See Installation Instructions).
- Avoid oversudsing by using the correct amount of detergent designed for automatic dishwashers.
- Check to see that dishwasher is level. **(See Installation Instructions).**

## Normal Sounds You Will Hear

- Normal sounds include water fill, water spray, draining and motor sounds.
  - There is a noticeable change in sound when the wash action switches between the lower and middle spray arm. This is normal since each spray arm has its own sound.
  - It is normal for the dishwasher to pause (no sound) when the wash action is switching between the lower and middle spray arms.
-



### Dishwasher Won't Run

- Check to see if circuit breaker is tripped or if a fuse is blown.
- Make sure water supply is turned on.
- Check to see if cycle is set correctly. (See Operating Instructions).
- Is dishwasher set for Delay Start Option?
- Make sure **START/Cancel button** is pressed after cycle has been selected.
- Make sure door is closed and latched immediately after pressing the **START/Cancel button**

### Dishwasher Won't Fill

- Assure the water supply is turned on.
- Check that the overfill protector moves up and down freely. (**See Overfill Protector section**).

### Dishwasher Does Not Drain Properly

- If unit is hooked up to a food waste disposer, make sure the disposer is empty.
- Assure the knockout plug has been removed from inside the food waste disposer inlet.
- Assure the drain hose isn't kinked.
- Make sure cycle is complete, not in a pause.
- Assure the glass trap is maintained and installed properly assuring no clogs (**See Care and Cleaning**).

### Dishwasher has an Odor

- Soiled dishes left in dishwasher too long can create an odor. Use **Rinse Only** cycle.
- There will be a "new" smell when first installed. This is normal.
- Check to see if unit is draining properly. (**See Dishwasher Does Not Drain Properly**).

### Stains on Tub Interior

- Washing large amounts of dishware with tomato based soil can cause a pink/orange appearance. This will not affect performance and will gradually fade over time. Pre-rinsing or using the **Rinse Only** cycle will reduce the chance of staining. Using no heat dry option will lessen staining.

### Opening the door during cycle

- If the dishwasher door is opened while the unit is running, the **START/Cancel button** must be pressed and the door shut immediately to return the unit to the selected cycle and option, this must happen within 10 minutes for the unit to continue the cycle.

### Removing Spots and Film

Hard water can cause lime deposit buildup on the interior of the dishwasher. Dishes and glasses may also get spots and film for a number of reasons. (**See Glassware/Flatware Spotted or Cloudy section**). To remove buildup, and film, clean using the following instructions:

1. Load clean dishes and glasses in normal manner. Do not load any metal utensils or silverware.
2. Do not add detergent.
3. Select the NORMAL WASH cycle. Press **START/Cancel button**. Close the door.
4. Allow dishwasher to run until it starts the second water fill (approximately 8 minutes).
5. Open the door, pour 2 cups of white vinegar into the bottom of dishwasher.
6. Press **START/Cancel button**. Close the door and allow cycle to finish.

# 20

## LIMITED WARRANTY

Your appliance is covered by a one year limited warranty. For one year from your original date of purchase, Electrolux will repair or replace any parts of this appliance that prove to be defective in materials or workmanship when such appliance is installed, used, and maintained in accordance with the provided instructions. The stainless tub and door liner of your appliance are covered by a lifetime limited warranty. During the lifetime of the appliance, Electrolux will provide a replacement stainless tub or door liner that fails to contain water due to a defect in materials or workmanship if the appliance is installed, used, and maintained in accordance with the provided instructions. In addition, the dishwasher racks and the electronic control module of your appliance are covered by a two through five year limited warranty. During the 2nd through 5th years from your original date of purchase, Electrolux will provide a replacement dishwasher rack or electronic control module for your appliance which has proven to be defective in materials or workmanship when such appliance is installed, used, and maintained in accordance with the provided instructions.

### Exclusions:

#### This Warranty does not cover the following:

1. Products with original serial numbers that have been removed, altered or cannot be readily determined.
2. Product that has been transferred from its original owner to another party or removed outside the USA or Canada.
3. Rust on the interior or exterior of the unit.
4. Products purchased "as-is" are not covered by this warranty.
5. Food loss due to any refrigerator or freezer failures.
6. Products used in commercial setting.
7. Service Calls which do not involve malfunction or defects in materials or workmanship, or for appliances not in ordinary household use or used other than in accordance with the provided instructions.
8. Service Calls to correct the installation of your appliance or to instruct you how to use your appliance.
9. Expenses for making the appliance accessible for servicing, such as removal of trim, cupboards, shelves, etc., which are not part of the appliance when it is shipped from the factory.
10. Service calls to repair or replace appliance light bulbs, air filters, water filters, other consumables, or knobs, handles, or other cosmetic parts.
11. Labor or in-home service costs during the additional limited warranty periods beyond the first year from your original date of purchase.
12. Pickup and delivery costs; your appliance is designed to be repaired in the home.
13. Surcharges including, but not limited to, any after hour, weekend, or holiday service calls, tolls, ferry trip charges, or mileage expense for service calls to remote areas, including the state of Alaska.
14. Damages to the finish of appliance or home incurred during transportation or installation, including but not limited to floors, cabinets, walls, etc.
15. Damages caused by: services performed by unauthorized service companies; use of parts other than genuine Electrolux parts or parts obtained from persons other than authorized service companies; or external causes such as abuse, misuse, inadequate power supply, accidents, fires, or acts of God.

### DISCLAIMER OF IMPLIED WARRANTIES; LIMITATION OF REMEDIES

CUSTOMER'S SOLE AND EXCLUSIVE REMEDY UNDER THIS LIMITED WARRANTY SHALL BE REPAIR OR REPLACEMENT AS PROVIDED HEREIN. CLAIMS BASED ON IMPLIED WARRANTIES, INCLUDING WARRANTIES OF MERCHANTABILITY OR FITNESS FOR A PARTICULAR PURPOSE, ARE LIMITED TO ONE YEAR OR THE SHORTEST PERIOD ALLOWED BY LAW, BUT NOT LESS THAN ONE YEAR. ELECTROLUX SHALL NOT BE LIABLE FOR CONSEQUENTIAL OR INCIDENTAL DAMAGES SUCH AS PROPERTY DAMAGE AND INCIDENTAL EXPENSES RESULTING FROM ANY BREACH OF THIS WRITTEN LIMITED WARRANTY OR ANY IMPLIED WARRANTY. SOME STATES AND PROVINCES DO NOT ALLOW THE EXCLUSION OR LIMITATION OF INCIDENTAL OR CONSEQUENTIAL DAMAGES, OR LIMITATIONS ON THE DURATION OF IMPLIED WARRANTIES, SO THESE LIMITATIONS OR EXCLUSIONS MAY NOT APPLY TO YOU. THIS WRITTEN WARRANTY GIVES YOU SPECIFIC LEGAL RIGHTS. YOU MAY ALSO HAVE OTHER RIGHTS THAT VARY FROM STATE TO STATE.

### If You Need Service

Keep your receipt, delivery slip, or some other appropriate payment record to establish the warranty period should service be required. If service is performed, it is in your best interest to obtain and keep all receipts. Service under this warranty must be obtained by contacting Electrolux at the address or phone numbers below.

This warranty only applies in the USA, Puerto Rico and Canada. In the USA and Puerto Rico, your appliance is warranted by Electrolux Major Appliances North America, a division of Electrolux Home Products, Inc. In Canada, your appliance is warranted by Electrolux Canada Corp. Electrolux authorizes no person to change or add to any obligations under this warranty. Obligations for service and parts under this warranty must be performed by Electrolux or an authorized service company. Product features or specifications as described or illustrated are subject to change without notice.

**USA**  
**1-800-374-4432**  
Frigidaire  
10200 David Taylor Drive  
Charlotte, NC 28262



**Electrolux**

**Canada**  
**1.800.265.8352**  
Electrolux Canada Corp.  
5855 Terry Fox Way  
Mississauga, Ontario, Canada  
L5V 3E4



# FRIGIDAIRE®

welcome *home*

Our home is your home. Visit us if you need help with any of these things:



owner support



accessories



service



registration

(See your registration card for more information.)

Frigidaire.com  
1-800-374-4432

Frigidaire.ca  
1-800-265-8352