

1

2

3

4

NOTES:

- 1. DEBURR AND BREAK ALL SHARP EDGES. MEET UL 1439.
- 2. PART SURFACES TO BE FREE OF TOOL MARKS.
- 3. DO NOT SCALE DRAWING, FOR DETAIL DIMENSIONS REFER TO 3D FILE.
- 4. MATERIAL: SEE COMPONENT DRAWINGS.
- 5. FINISH TO PASS LIBERTY HARDWARE QC-0034.
- 6. PARTS AND ASSEMBLIES ARE TO MEET OR EXCEED MINIMUM TEST SPECIFICATIONS REQUIRED BY ANSI/BHMA A156.16
- 7. BACK OF PRODUCT TO BE MARKED: L H M C © 2020.

REV.	DESCRIPTION	DATE	ENG.
A	INITIAL DRAWING	7-21-22	MG
B	UPDATED DIMENSIONS	9-12-22	MG
C	UPDATED DIMENSIONS	8-8-23	MG
D	REVISED DESIGN	9-25-23	MG

State: Design
Modified On: 19-Sep-23 04:16:45 PM

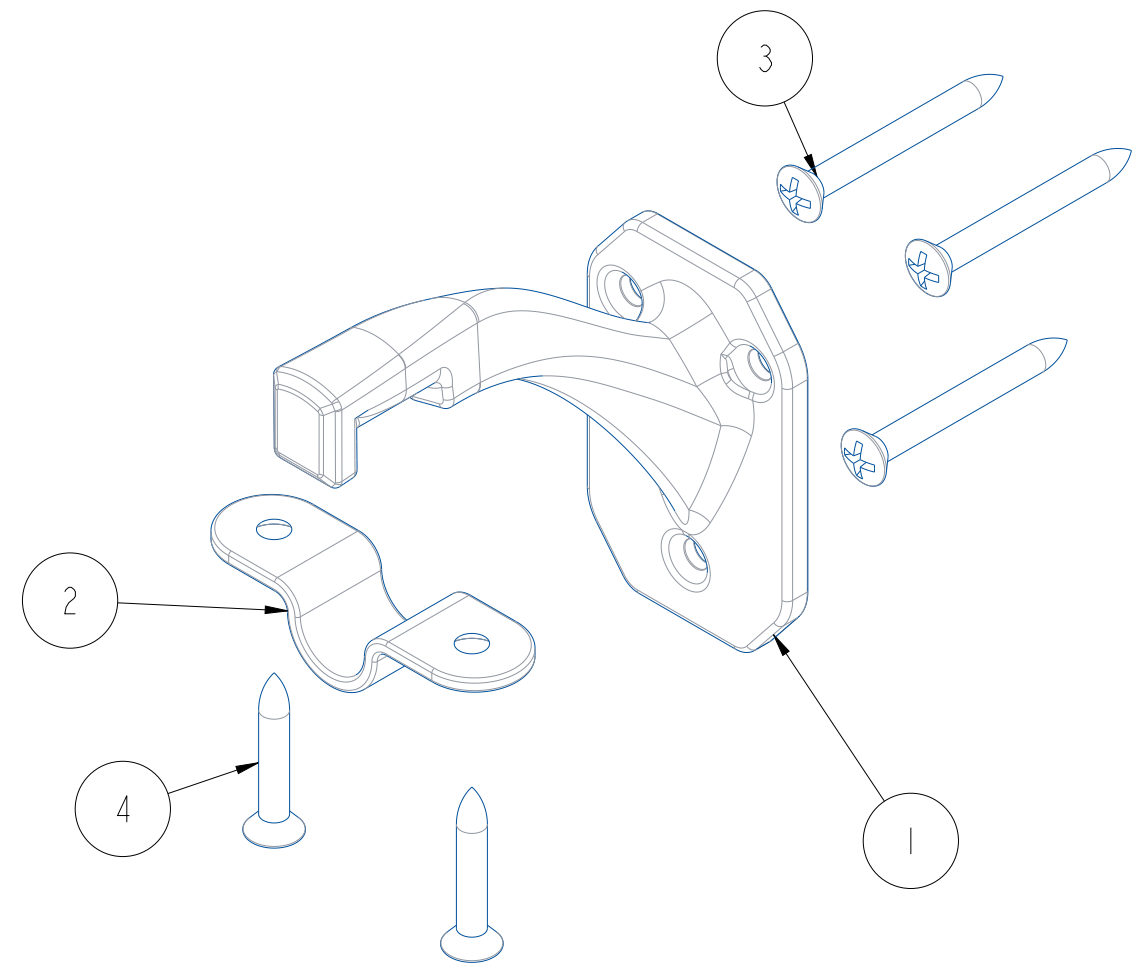
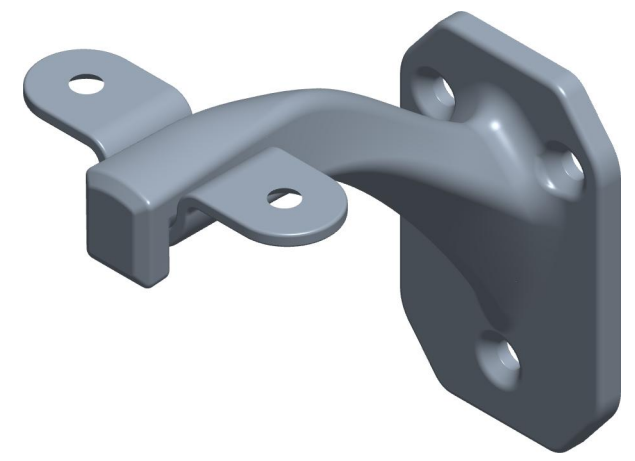

STRAP & SCREWS
PACKAGED SEPARATELY

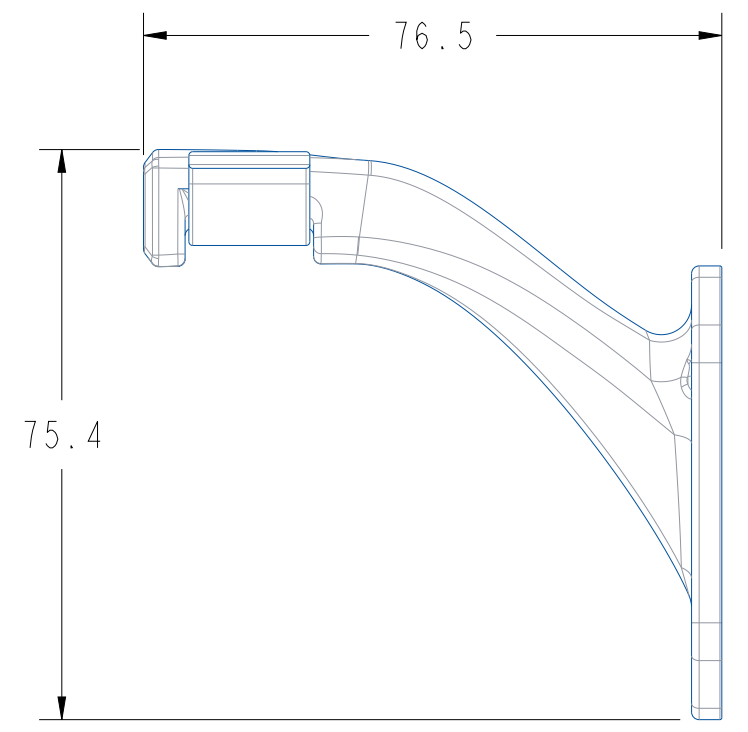
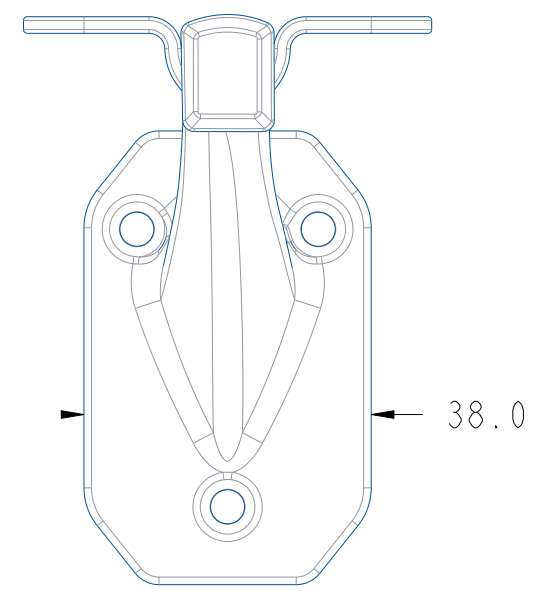

ITEM NO.	PART NUMBER	DESCRIPTION	QTY	MATERIAL	WEIGHT EA (g)	DRAWING NUMBER
1	TBD	COORD Napier HRB ARM	1	ZAMACK_3	121.8	47257_A
2	TBD	COORD HRB STRAP	1	STEEL	15.8	47283
3	STPOE80	#8 X 1-1/2 PHILLIPS OVAL HEAD TAPPING SCREW	3	STEEL	4.2	NO DWG
4	STPOE8L	#8 X 1" PHILLIPS OVAL HEAD TAPPING SCREW	2	STEEL	2.9	NO DWG

NOTICE: PROPRIETARY INFORMATION
 THESE DRAWINGS AND SPECIFICATIONS ARE THE PROPERTY OF LIBERTY HARDWARE, MFG CORP. AND ARE NOT TO BE REPRODUCED, COPIED OR USED AS THE BASIS OF MANUFACTURE OR SALE OF APPARATUS AND DEVICES WITHOUT PERMISSION. THESE DRAWINGS AND SPECIFICATIONS CONTAIN COPYRIGHTED INFORMATION THAT IS PROPRIETARY TO LIBERTY HARDWARE AND SHALL NOT BE DIVULGED IN ANY WAY WITHOUT PERMISSION.

	LIBERTY HARDWARE <small>LIBERTY HARDWARE MANUFACTURING CORPORATION 140 Business Park Drive Winston, Salem, NC 27107</small>		DWG. SIZE B <small>(11 x 17 in.)</small>
	Dr. By: MG Ck. By:	DESCRIPTION: COORD Napier HRB	
TOLERANCE MM TOL. UNLESS NOTED X. = ±1. X.X = ±0.5 X.XX = ±0.1 HOLES: ±0.1 ANGLES: ±1.0	ENG. Appd: SCALE: DATE: 07/21/22	DWG #. 47257 SHEET. 1 OF 2 PART #. TBD	WT. (grams) 155.8 REV. A

1

2

3

4

NOTES:

1. DEBURR AND BREAK ALL SHARP EDGES. MEET UL 1439.
2. PART SURFACES TO BE FREE OF TOOL MARKS.
3. DO NOT SCALE DRAWING, FOR DETAIL DIMENSIONS REFER TO 3D FILE.
4. MATERIAL: ZAMACK 3.
5. FINISH TO PASS LIBERTY HARDWARE QC-0034.
6. PARTS AND ASSEMBLIES ARE TO MEET OR EXCEED MINIMUM TEST SPECIFICATIONS REQUIRED BY ANSI/BHMA A156.16
7. BACK OF PRODUCT TO BE MARKED: L H M C © 2020.

REV.	DESCRIPTION	DATE	ENG.
A	INITIAL DRAWING	7-21-22	MG
B	UPDATED DIMENSIONS	09/09/22	DSC
C	UPDATED DIMENSIONS	8-8-23	MG
D	REVISED DESIGN	9-25-23	MG

State: Design
Modified On: 19-Sep-23 01:45:11 PM

SCALE 1.000

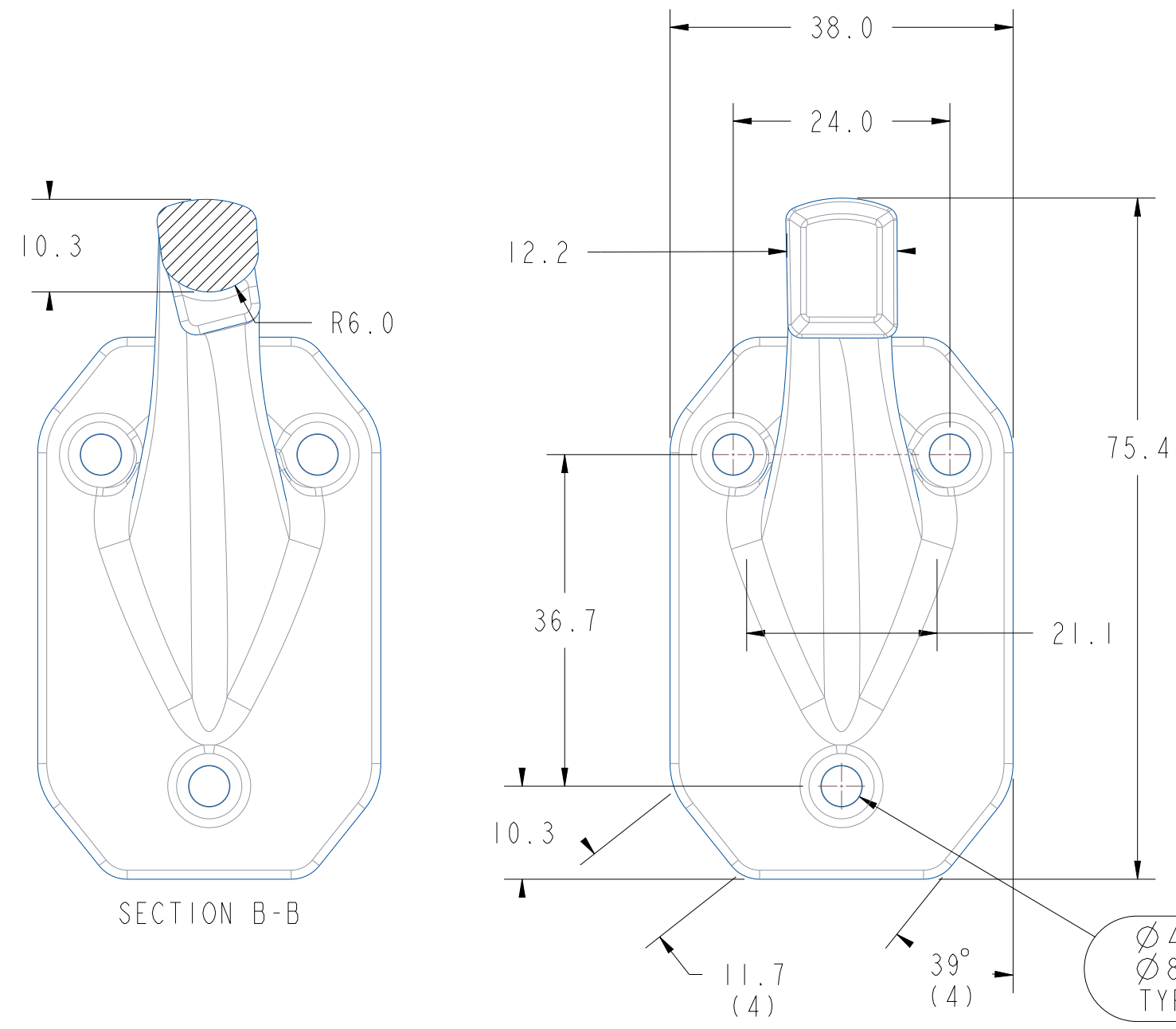

SECTION B-B

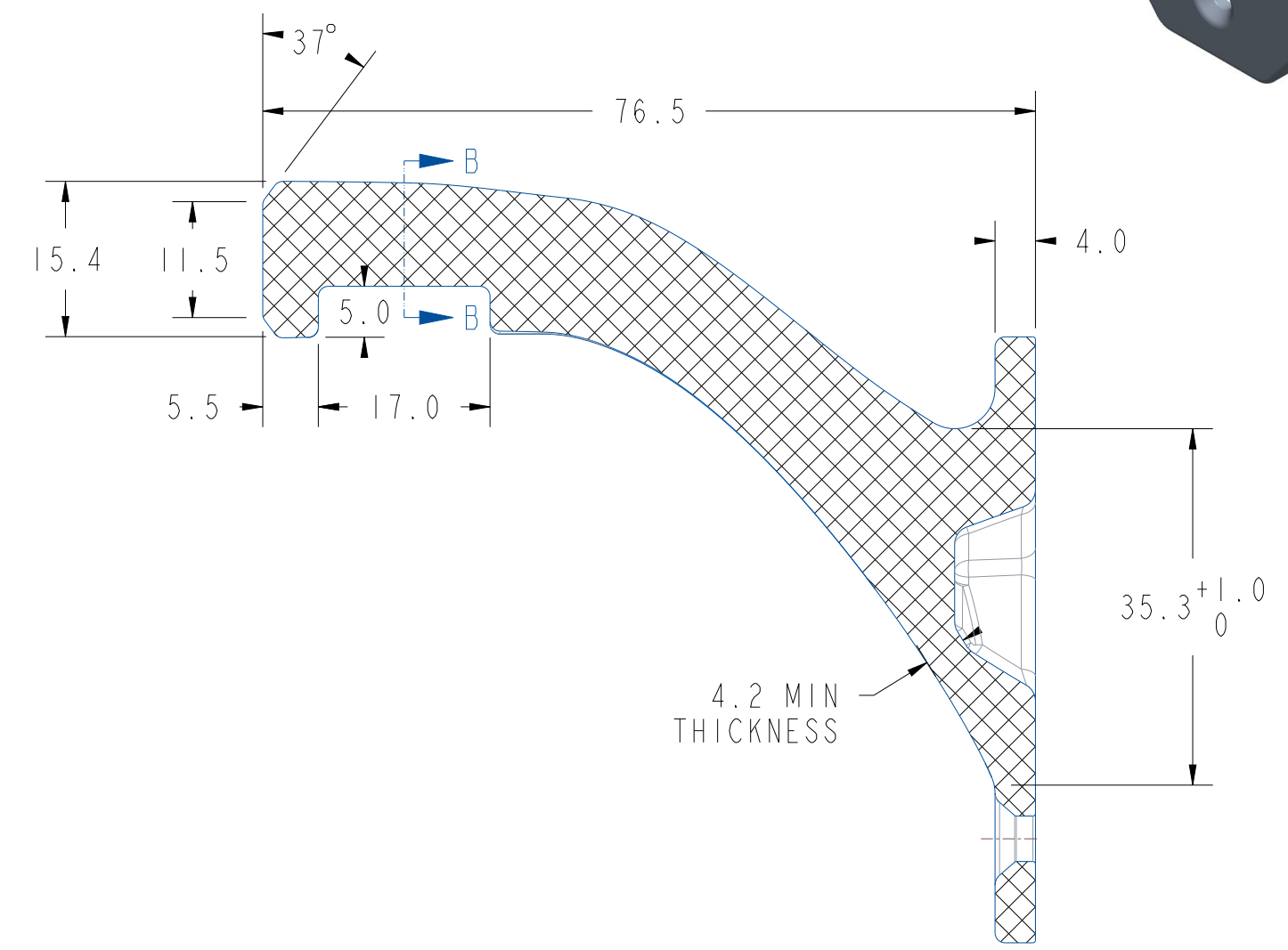

SECTION A-A

Ø4.6 THRU HOLE
Ø8.5 x 82° CSK
TYP (3) HOLES

NOTICE: PROPRIETARY INFORMATION
THESE DRAWINGS AND SPECIFICATIONS ARE THE PROPERTY OF LIBERTY HARDWARE, MFG CORP. AND ARE NOT TO BE REPRODUCED, COPIED OR USED AS THE BASIS OF MANUFACTURE OR SALE OF APPARATUS AND DEVICES WITHOUT PERMISSION. THESE DRAWINGS AND SPECIFICATIONS CONTAIN COPYRIGHTED INFORMATION THAT IS PROPRIETARY TO LIBERTY HARDWARE AND SHALL NOT BE DIVULGED IN ANY WAY WITHOUT PERMISSION.

Third-angle projection	LIBERTY HARDWARE LIBERTY HARDWARE MANUFACTURING CORPORATION 140 Business Park Drive Winston, Salem, NC 27107		DWG. SIZE B (11 x 17 in.)
	Dr. By: MG	DESCRIPTION: COORD Napier HRB ARM	
TOLERANCE MM TOL. UNLESS NOTED X. = ±1. X.X = ±0.5 X.XX = ±0.1 HOLES: ±0.1 ANGLES: ±1.0	Ck. By:	DWG #. 47257	SHEET 2 OF 2
SCALE: 1:500	ENG. Appd:	PART #. TBD	WT. (grams) 121.8
DATE: 07/21/22	DATE:	REV. B	