

INSTALLATION DIMENSIONS

Serie Scala

8469700

Pressure Balance Trim Only

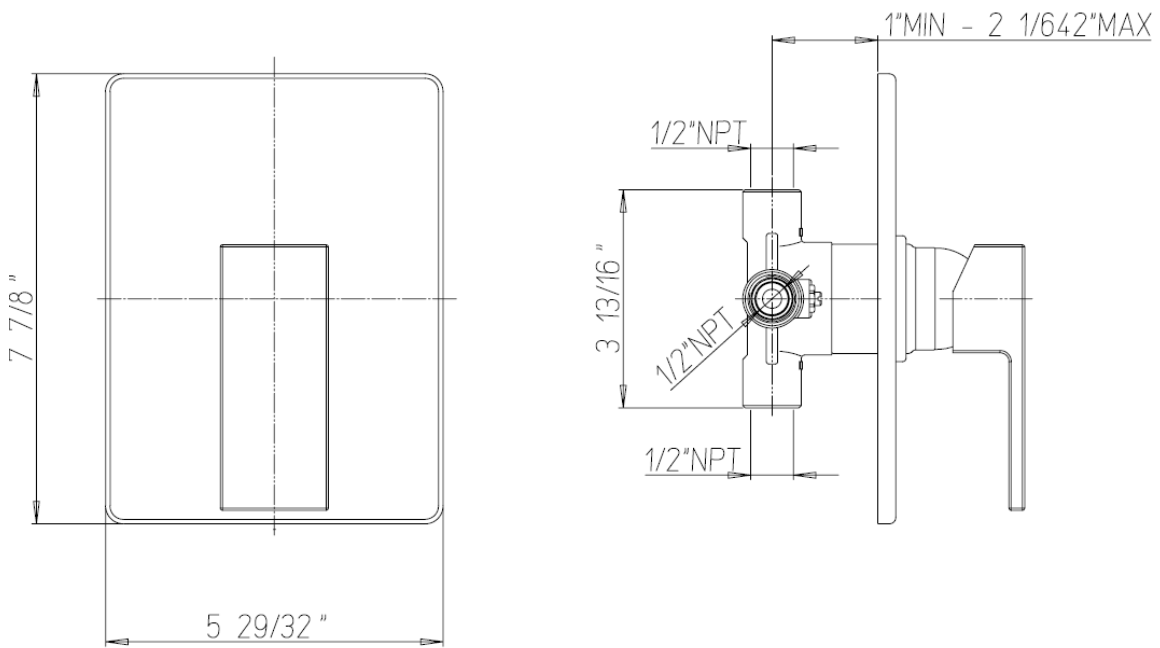

1-877-55-FORTIS (36784)

19701 Da Vinci
Lake Forest, CA 92610

WWW.FORTISFAUCET.COM

FORTIS.
PURO DESIGN ITALIANO

Serie Scala

8469700

Pressure Balance Trim Only

STANDARDS

- Compliant with ASME A112.18.1-B125.1
- Compliant with ASSE 1016
- Certified by CSA International
- Compliant with ANSI A117.1 (Lever Only)

Finishes	8468700PC	8468700BN
Polished Chrome	X	
Brushed Nickel		X

Features	8468700PC	8468700BN
Pressure Balance Trim	X	X
Includes pressure balance cartridge	X	X
1/2" Pressure Balance Valve featuring Ceramic Discs	X	X
1/2" NPT Inlets	X	X
ADA Compliant	X	X
Step-By-Step Installation Instructions	X	X
Limited Lifetime Warranty	X	X

Project: _____
 Contractor: _____

