

Serie Corsini

84788SQ

Pressure Balance Valve Trim with Diverter only

STANDARDS

- Compliant with ASME A112.18.1-B125.1
- Compliant with ASSE 1016T
- Certified by CSA International
- Compliant with ANSI A117.1

| Finishes | 84787SQPC | 84787SQBN |
|-----------------|-----------|-----------|
| Polished Chrome | X | |
| Brushed Nickel | | X |

| Features | 84787SQPC | 84787SQBN |
|---|-----------|-----------|
| Pressure Balance Trim | X | X |
| Includes pressure balance cartridge | X | X |
| 1/2" Pressure Balance Valve featuring Ceramic Discs | X | X |
| 1/2" NPT Inlets | X | X |
| ADA Compliant | X | X |
| Step-By-Step Installation Instructions | X | X |
| Limited Lifetime Warranty | X | X |

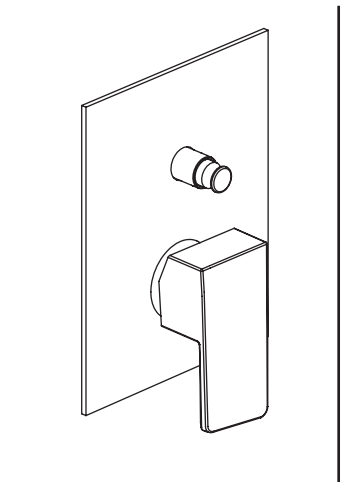

Project _____

Contractor _____