

**VALVE788**

1/2" Pressure Balance  
Rough-in Valve with diverter

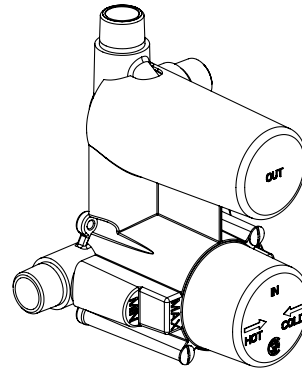

**STANDARDS**

- Compliant with ASME A112.18.1 B125.1 when sold with external trim
- Certified by or IAPMO R&T Lab when sold with external

**FEATURES**

- Pressure Balance with 2 way diverter
- 1/2" NPT connections
- Mechanical diverter
- Flows 5.0 GPM @ 60 PSI
- Step-By-Step Installation Instructions
- Limited Lifetime Warranty
- Includes Test Plug

**DIMENSIONS**

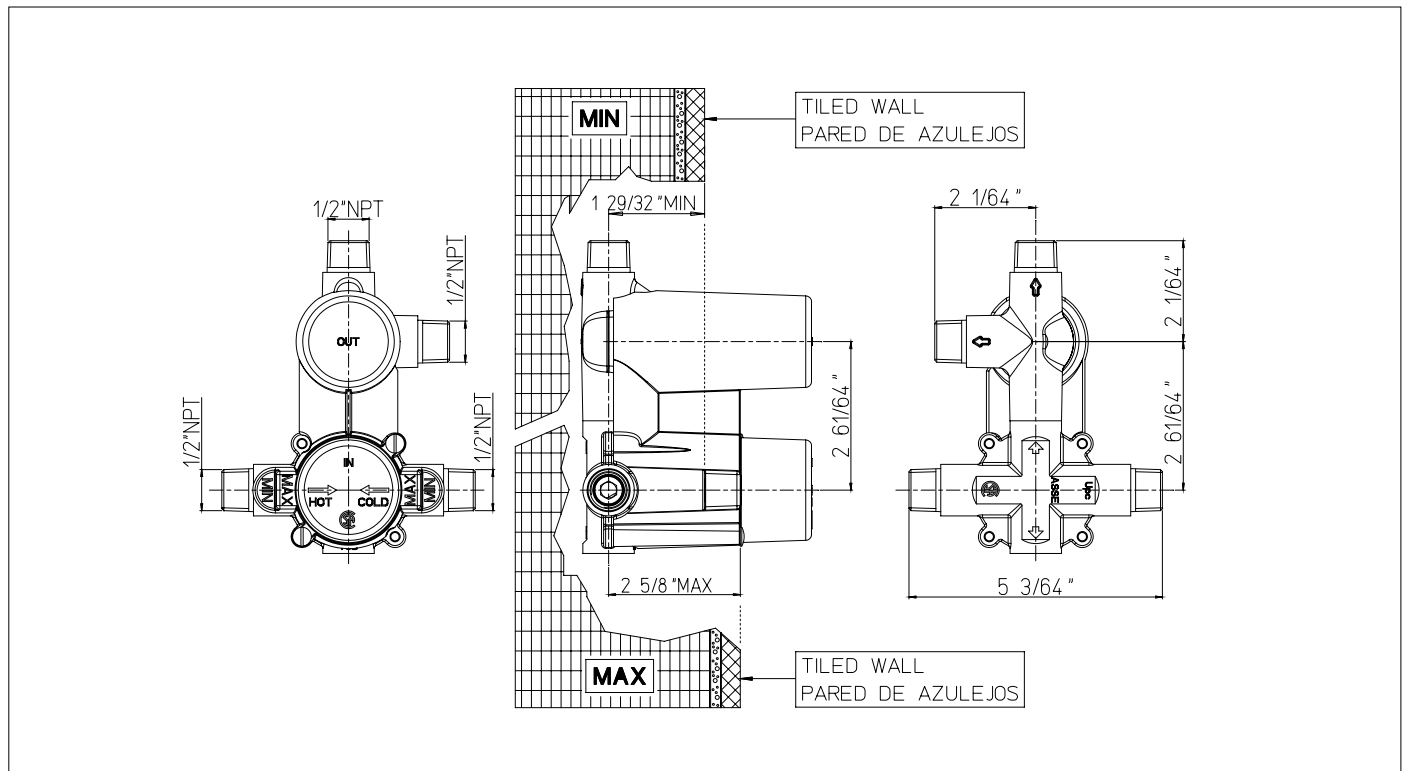

Project \_\_\_\_\_  
Contractor \_\_\_\_\_