

Integrated Double DishDrawer™ Dishwasher, Tall, Sanitize

Series 9 | Integrated

Panel Ready



Doing the dishes got easier. Load one drawer while the other washes – with the top drawer fitting your large dinner plates easily.

- Knock to pause function is perfect if you miss a dish
- Six wash programs, as well as additional Quick wash, Sanitize and Extra Dry options
- Flexible racking can be folded down to fit bigger dishes

- Customize with your own kitchen cabinetry or purchase our stainless steel door panel accessory

DIMENSIONS

Height	34 - 36 3/8"
Width	23 9/16"
Depth	21 3/4"

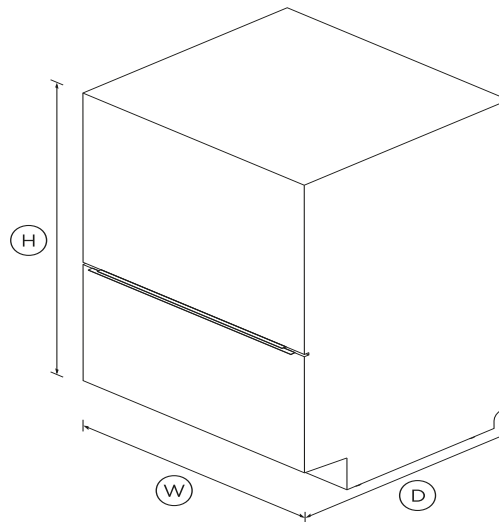

FEATURES & BENEFITS

SEAMLESS INTEGRATION

Slide your DishDrawer™ Dishwasher into an existing kitchen space or integrate into kitchen cabinetry, for a seamless look whilst delivering superior dish care.

EASE OF USE

DishDrawer™ Dishwashers are as easy to open and close as

kitchen drawers and can be conveniently positioned at bench height for ease of loading and minimal bending. Flexible racking allows you to make adjustments to fit in a variety of dishes.

INDEPENDENT WASH

With the ability to use both drawers independently and select different wash programs the DishDrawer™ Dishwasher can wash everything from fine glass and crystal to heavily soiled pots and pans.

TRUE HALF LOAD

Each drawer holds a true half load for guilt-free small washes and fast turnaround of your dishes. Both drawers operate independently so different wash cycles can run simultaneously to accommodate a variety of loads.

QUICK, SANITIZE AND EXTRA DRY OPTIONS

The Quick wash modifier delivers a faster wash while maintaining performance. The Sanitize option provides extra protection killing 99.9% of bacteria in the final rinse. The Extra Dry setting is perfect for plastic dishes.

KNOCK TO PAUSE

Instead of needing a remote control, these DishDrawer™ Dishwashers have a knock to pause function. A knock on the front panel will pause the dishwasher which can be re-started again by using the start/play button.

QUIET PERFORMER

Running at a very low decibel rating, these DishDrawer™ dishwashers do their job without making a fuss. The combination of intelligent technology and simple mechanics means greater reliability and excellent wash performance.

SPECIFICATIONS

Accessories

- Cutlery basket
- Kickstrip
- Knife clip and multipurpose

Accessories (sold separately)

Door panel stainless steel	ADDD24DTPX
Handle kit Contemporary	AHS-OBDD-60S
Handle kit Contemporary	AHD5-OBDD-60SX
Handle kit Contemporary	AHD5-OBDD-60SB
Handle kit Contemporary	AHD3-OBDD-60S
Handle kit Professional round	AHP3-DWDD-SX

Capacity and loading

Accommodates round plates	12.25" (top) 11" (bottom)
Adjustable height, foldable	•
Fold down tines	•
Pitch adjustable tines	•
Place settings	14

Consumption

Energy usage	263kWh/year
Water usage (per wash cycle)	3.28 gal running both tubs

Controls

Child lock	•
Electronic fault/Diagnostic	•
End of cycle beeps	•
Energy saving delay start	•
Internal wash selector	•
Knock to pause	•
Rinse aid indicator light	•
Wi-Fi connectivity	•

Features

Fan assisted drying	•
Flood protection	•
Flow through detergent	•
Quiet operation	•
SmartDrive™ technology	•

Performance

Noise on standard cycle top	43dBA
-----------------------------	--------------

Power requirements

Amperage	10A
Electric circuit	3 wire
Rated current	15A
Supply frequency	60Hz
Supply voltage	100 - 120V

Product dimensions

Depth	21 3/4"
Height	34 - 36 3/8"
Width	23 9/16"

Warranty

Parts and labor	Limited 2 years
-----------------	------------------------

Wash Program Modifiers

Extra Dry	•
Quick	•
Sanitize	•
Wash modifiers	3

Wash Programs

Delicate	•
Eco	•
Fast	•
Heavy	•
Medium	•
Rinse	•
Wash programs	6

Water connection

Inlet water temperature	max 140°F
Supplied hose to suit 3/8"	•
Water pressure	30kPa - 1000 kPa
Water supply	3/8" to suit Male Compression

SKU	82338
-----	--------------

The product dimensions and specifications in this page apply to the specific product and model. Under our policy of continuous improvement, these dimensions and specifications may change at any time. You should therefore check with Fisher & Paykel's Customer Care Centre to ensure this page correctly describes the model currently available. ? Fisher & Paykel Appliances Ltd 2020

Other product downloads available at fisherpaykel.com



Quick Start Guide



Service & Warranty



Energy Label Double DishDrawer™ Dishwasher



User Guide DishDrawer™ Dishwasher



Energy Label Double DishDrawer™ Dishwasher



Installation Guide Double DishDrawer™ Dishwasher



Installation Guide Double DishDrawer™ Dishwasher



Data Sheet Integrated Double DishDrawer™ Dishwasher



A PEACE OF MIND SALE

24 Hours 7 Days a Week Customer Support

T 1.888.936.7872 **W**www.fisherpaykel.com