

Dual Fuel Range, 48", 5 Burners with Griddle, Self-cleaning

Series 9 | Professional

Stainless Steel | Natural gas



With intuitive touchscreen and specialized cooking functions across two ovens, this range is a stand-out addition to your kitchen.

- Guided cooking using your touchscreen makes it simple to cook by food, function or recipe.
- Gas cooktop with griddle and a top burner heat up to 23,500 BTU, for seriously fast boiling
- 6.9 cu ft total oven capacity across two oven cavities

- Ensure perfect results with the food probe, included

DIMENSIONS

Height	35 3/4 - 36 3/4"
Width	47 7/8"
Depth	29 1/8"

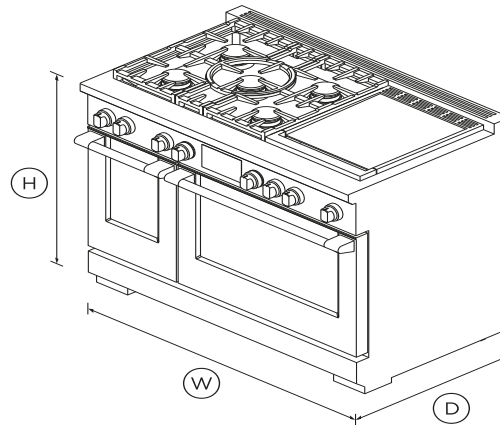

FEATURES & BENEFITS

Cook with confidence

Our touchscreen interface provides an intuitive guided cooking experience that helps deliver perfect results, whether you've been cooking all your life or just starting out. Cook with a favorite method, a hero ingredient, or a go-to cooking function or recipe. The screen tilts for improved ergonomics and optimal visibility while cooking.

Generous capacity

Two independently operating cavities provide a large total capacity of 4.8 cu. ft. in the main cavity and 2.1 cu. ft. in the secondary. That's enough room for a 32 lb turkey in one oven, and your sides in the other.

Cooking flexibility

No matter what you're cooking, you've got the right heat to get perfect results. Each of the 15 oven functions in the main cavity and 11 in the secondary have been extensively researched and carefully designed to cater to a broad range of dishes and cooking styles. The handy food probe helps you monitor your progress.

Cooktop power

Sealed dual flow burners deliver cooktop power up to 23,500 BTU for seriously fast boiling, and precise 140°F full surface, low temperature cooking with the gentlest of flames.

Design quality

This range has craftsmanship in every detail, with real stainless steel, cast-iron grates, and beautifully weighted, halo illuminated dials. Each cavity features incandescent lights and full extension telescopic racks. From the robust legs to the powerful cooktop, this Range is built to last.

Easy to clean

The oven features a self-cleaning function and self-clean proof side racks, which don't need to be removed when using this function.

SPECIFICATIONS

Accessories

Square handle option **AH-R48**

Burner ratings

Maximum burner power **23500 BTU**

Power back centre	23500BTU
Power back left	18500BTU
Power back right	18500BTU
Power front left	18500BTU
Power front right	18500BTU
Power griddle	24000BTU
Total cooktop power	121500 BTU

Capacity

Shelf positions	5
Shelf positions	5
Total capacity second oven	2.1cu ft

Cleaning

- Dishwasher proof grates •
- Pyrolytic self-clean •

Controls

- Dial with illuminated halo •
- Electric circuit **4 wire**
- High resolution display •
- Metal illuminated dials •
- Multi-language interface •
- Precise cooking with food •
- Recipe and food based •
- Sabbath mode •
- Tilting touch screen interface •
- Wi-Fi connectivity •

Gas Requirements

Fitting and pipe	½ NPT, min. ⅝" flex line
Supply Pressure (natural gas)	6" to 9" W.C

Oven features

- Concealed element •
- Electronic oven control •
- Full extension telescopic •
- Internal light •
- Titanium coated, illuminated •

Oven functions

- Dehydrate •
- Pastry bake •
- Warm •

Oven performance

Bake power	4600
Broil	3600W
Main oven - True convection	2500W

Power requirements

Amperage	50A
Rated current	50A
Supply frequency	60Hz

Product dimensions

Depth	29 1/8"
Height	35 3/4 - 36 3/4"
Width	47 7/8"

Rangetop features

- Sealed Dual Flow Burners™ **5**
- Sealed range top •
- Vent trim included •

Recommended Back Guards Ventilation

Combustible situation	BGRV3-3048H
Non combustible situation	BGRV2-3048 / BGRV2-1248
Recommended hood	HCB48-12_N (48"")

Safety

- ADA compliant •

Secondary oven features

- 3/4 Extension racks **2**
- Concealed element •
- Electronic oven control •
- Food probe •
- Internal light •

Secondary oven functions

- Air fry •
- Bake •
- Classic bake •
- Convection bake •
- Convection broil •
- Maxi broil •
- Number of secondary oven **11**
- Pastry bake •

- Pizza bake •
- Rapid proof •
- Roast •
- Warm •

SKU 81894

The product dimensions and specifications in this page apply to the specific product and model. Under our policy of continuous improvement, these dimensions and specifications may change at any time. You should therefore check with Fisher & Paykel's Customer Care Centre to ensure this page correctly describes the model currently available. ? Fisher & Paykel Appliances Ltd 2020

Other product downloads available at fisherpaykel.com

- [↓](#) User Guide
- [↓](#) Guide d'utilisation
- [↓](#) User Guide
- [↓](#) Installation Guide
- [↓](#) Specification Guide Dual Fuel Range
- [↓](#) Data Sheet Dual Fuel Range
- [↓](#) Planning Guide Dual Fuel Range



A PEACE OF MIND SALE

24 Hours 7 Days a Week Customer Support

T 1.888.936.7872 W www.fisherpaykel.com