

CO-502W
High temp dishwasher - Undercounter



QUICK VIEW	
Dimensions: H x W x D	23 5/8" x 23 5/8" x 32 3/4"
Weight : net/crated (lbs)	132 / 170
Voltage	208-230V/1Ph/60Hz
Total Power	6.2 KW
Wash pump (HP)	3/4

SHORT FORM SPECIFICATION

The unit provided to be a Fagor EVO Concept dishwasher model CO-502W. The Concept dishwashers come with the following, Effi Wash, Effi Silent, Eco Fill, Soft Start and Multi-tension systems.

The unit is constructed with ANSI 304 stainless steel stamped design including wash tank, guides and control panel. IPX4 - Protection against water jets on control panel. Built-in detergent, rinse and drain pumps, rinse aide dispenser, 15-1/4" clearance.

Each unit comes standard with one (1) flat rack, one (1) peg rack and one (1) cutlery container. Designed to be used as a Glasswasher or Dishwasher.

Production:

30 racks per hour.
Standard rack size 20" x 20"

Functions and Benefits

Fagor's Concept range of dishwashers combines features and benefits that only high-end ranges are offering, becoming in a product easy to use and efficient, with the most effective and robust technology prepared for the strongest usage of the market. Built in durable stainless steel with electromechanical components and simple digital controls with temperature display for a user-friendly operation.

- **Effi Wash:** Optimized hydraulic system provides a strong mechanical action combined with the optimum clean water in the tank. Balanced power keeps the perfect sanitation temperature during the cycle of the wash.
- **Soft Start:** Wash-pump power control that prevents wares from damage at the beginning of the washing cycle while assuring a low noise level.
- **Hot water assurance:** Working in series with the booster heater, this relay insures the timer will not advance to the rinse cycle until the sanitation temperature of the rinse water (180 °F) is met.
- **Digital Controls:** Simple digital control panel with temperature display for intuitive and user-friendly operation, IPX-4 proof.
- This unit is designed to be used as a **Glasswasher or Dishwasher**.

Construction

- New **stainless steel body** structure with **stamped design** (wash tank, rack guides, control panel.), made to resist strong usage.
- **AISI-304 Stainless steel double wash/rinsing arms and tray filters.**
- Higher clearance: 15 1/4".
- **Rock counterbalanced door.** Double spring and stainless steel hinge system tested to resist the strongest usage. Safe 3 step open system: remove steam (1), check rack (2), and remove/place rack (3).
- **IPX4** - Stronger protection against water hose cleaning and external humidity.
- **Multi-connection box:** Conveniently located electrical box for easy access that improves maintenance and allows for multi-tension.
- **Built-in detergent, rinse and drain pumps.**
- **Built-in pressure gauge.**

Accessories

- Racks for dishes, glasses and trays
- Cutlery containers and grids
- 6" & 16" high base stands
- Drain tempering valve



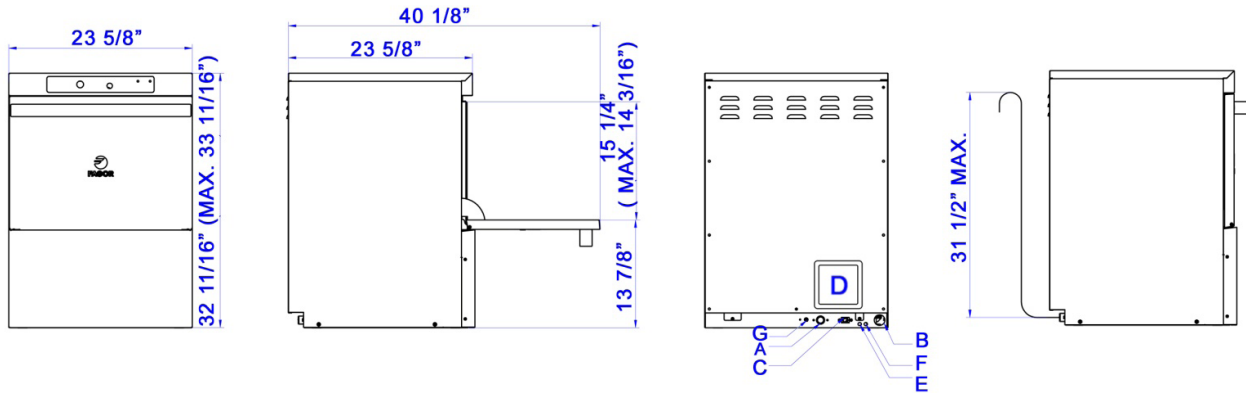

A	B	C	D	E	F	G
Water inlet *	Drain hose **	Power supply cable, strain relief	Terminal box	Rinse aid inlet	Detergent inlet	Equipotential bond ***
<p>* Water inlet 3/4" female hose connector on 5' long flexible hose supplied with machine. Adaptor for 3/4" female garden hose fitting also supplied. 120°-140°F optimum water temperature; 20 -25 psi flow rinse pressure.</p> <p>** Drain 5' long, 1/2" I.D. flexible hose. Maximum 26 3/4" drain height permits indirect connection to drain pump.*** Protection from dangerous potential differences</p>						

SPECIFICATIONS	COP- 504W	
Wash Cycles (seconds)	90-120-180	
Hot water assurance	●	
Electronic control panel and digital display	●	
Productivity (*)		
Racks/hour	30	
Dishes/hour	540	
Glasses/hour	1080	
Standard Rack size (inches)	19 3/4 x 19 3/4	
Weight : Net/Crated (lbs)	132 / 170	
Dimensions (inches)		
	Unit	Shipping
Width	23 5/8	27 1/4
Depth	23 5/8	30 1/2
Height	32 3/4	39 1/2
Useful Loading Height (clearance)	15 1/4	
Capacity (gallons)		
Wash Tank	5.28	
Boiler	1.85	
Water consumption per cycle	0.63	

SPECIFICATIONS	CO-502W	
Wash pump motor (HP)	3/4	
Power (kW)		
Tank heating element	2.8	
Boiler/Booster heating element	2.8	
Wash pump(s)	0.6	
Total power	3.5	
Minimum Working Temperature		
Washing (°F)	150	
Rinsing (°F)	180	
AMP for 60 Hz		
Volts	1 Phase	
208	15 Amp	
220	16 Amp	
240	17 Amp	
Water Protection Rating	IPx4	
Noise level (dBA)	<65	
Detergent & rinse dispenser	●	
Drain pump	●	
Power cord supplied	●	

(*) Assumed 18 dishes and 36 glasses per rack

The manufacturer reserves the rights to modify materials and specifications without notice.