

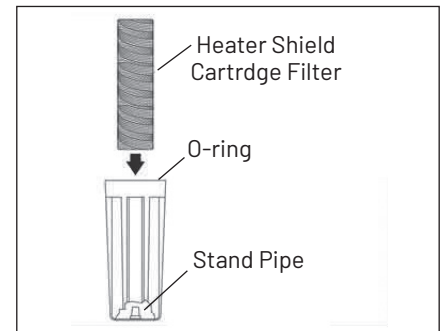

WATER HEATER SHIELD 3/4" Installation Instructions

Step 1 – Heater Shield Assembly

- A) Unscrew the cover from the Heater Shield housing.
- B) Place the cartridge filter onto the stand pipe in the Heater Shield housing.
- C) Lube the o-rings with clean silicone grease before attaching the cover onto the housing (lube is included).
- D) Hand tighten the Heater shield housing (counter clockwise). Do not use wrench.

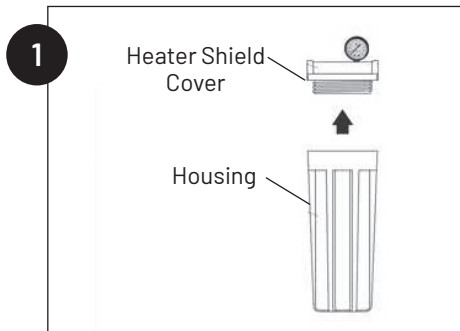

Notice

Pressure Release Valve

When it comes time to open your Heater Shield housing, be sure to turn off your water and press the pressure release valve prior to attempting to use the wrench to open the housing by turning clockwise.

Pressure Release Valve

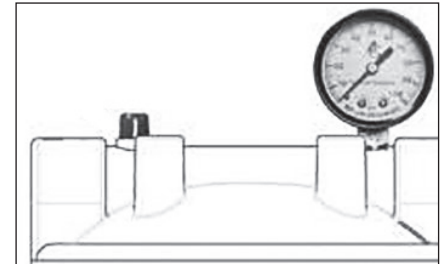

Notice

Warning: Do not exceed 80 PSI. If your water pressure is above 80 psi, you must install a pressure regulator.

Note: To prevent thermal expansion into the unit, you must install a check valve on the outside of the Water Heater Shield unit.

Note: Install on cold water inlet of water Heater. Do not run hot water through the Water Heater Shield.

Warranty is void if water temperature exceeds 120°F.

Step 2 – Heater Shield Installation

- A) Shut off the water.
- B) Attach the mounting bracket to the wall using the supplied Phillips head screws and washers.
- C) Attach the Heater shield system to the mounting bracket using the supplied bolt head screws.
- D) Finish by attaching plumbing with 1" male threaded adaptations.

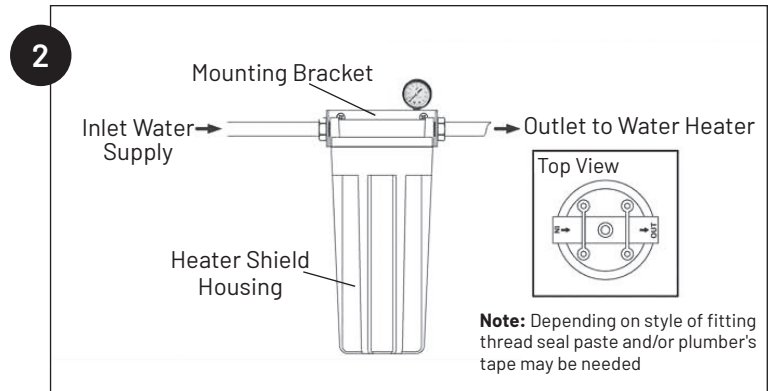

Step 3 – Pressure Gauge Installation

- A) To install the pressure gauge, put 1-2 wraps of plumber's tape (not provided) on the metal threads.
- B) Use a wrench on the brass base to install. Complete turning of the gauge until it faces forward.
NOTE: Do not tighten pressure gauge from the black casing
- C) Turn on water and check for leaks.
- D) Apply Heater shield decal to housing.
- E) Note initial pressure reading, replace cartridge filter when there is a 10 psi drop or every six (6) months.

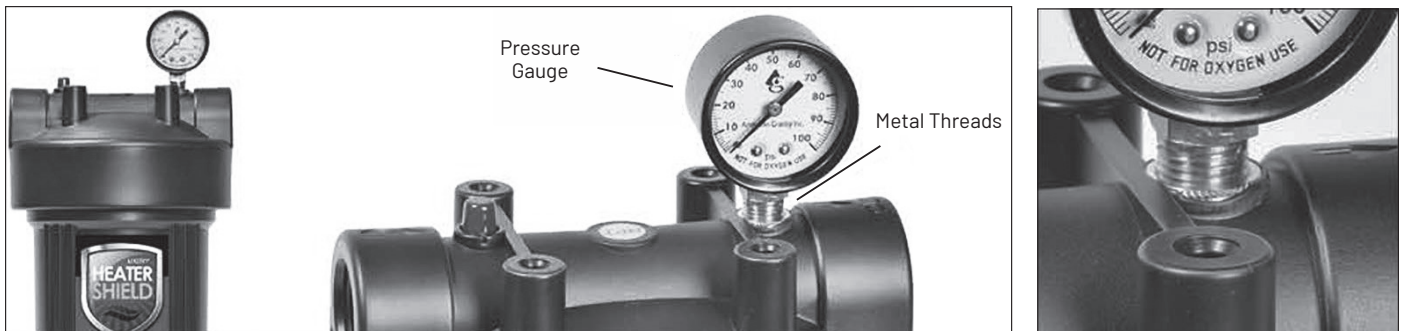

13845 Bishops Dr. | Suite 200 | Brookfield, WI 53005 | United States
P: 262.238.4400 | Customer Service: 800.279.9404 | tech-support@pentair.com | pentair.com

All indicated Pentair trademarks and logos are property of Pentair. Third party registered and unregistered trademarks and logos are the property of their respective owners.

© 2023 Pentair. All rights reserved.

4006085 Rev B JE23