

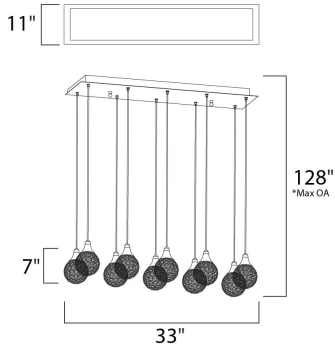

**PRODUCT DESCRIPTION**

With formed metal spheres of Polished Chrome framing multifaceted crystal jewelry, the Brilliant Collection adds a touch of contemporary elegance to any design space. The illumination of xenon lamps reflecting through the crystal offers added brilliance by creating a spectrum of color.



\*max overall height

**MEASUREMENTS**

DIMENSION : 33." L x 11." W x 7." H  
 BACK PLATE OAH : 128." OAH x 18." OAH  
 HANGING WEIGHT : 24.2 lb

**LAMPING**

LUMENS : 5,000 Rated  
 BULB : 1 x 40W (INCLUDED), 400W Total  
 DIMMABLE : Dimmable  
 COLOR\_TEMP : 2900K

**FINISHES OPTION**

Polished Chrome PC

**GLASS**

Crystal 20

**MATERIAL**

Steel + Crystal

**CERTIFICATION**

Dry Location  
 Dimmable



**ADDITIONAL**

INSTALL UP/DOWN:  
 RATED LIFE 2000 Hours  
 OPERATING TEMPERATURE:  
 -20°C (-4°F), 40°C (104°F)

Always consult a qualified electrician before installing any lighting product.



**WESTERN DISTRIBUTION CENTER (HEADQUARTER)**  
 253 NORTH VINELAND AVE | CITY OF INDUSTRY, CA 91746  
**EASTERN DISTRIBUTION CENTER**  
 4200 SHIRLEY DR. | ATLANTA, GA 30336  
 P. 626.956.4200 | F. 626.956.4225 | et2online.com