

1. Install Lock Body

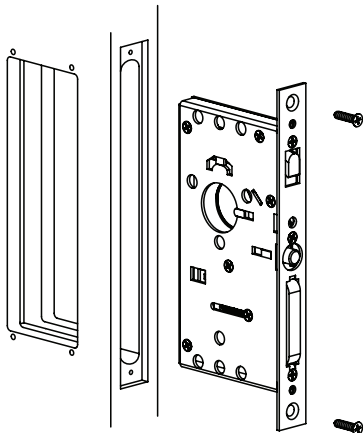

See template for door prep specifications

2. Install Drive Bar Cylinder

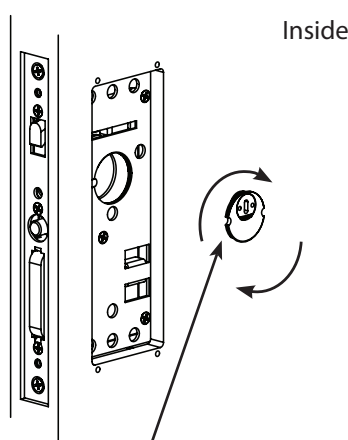

Note: Notch on cylinder must be in the 9 o' clock position when fully screwed into lock body.

3. Tighten Drive Bar Cylinder

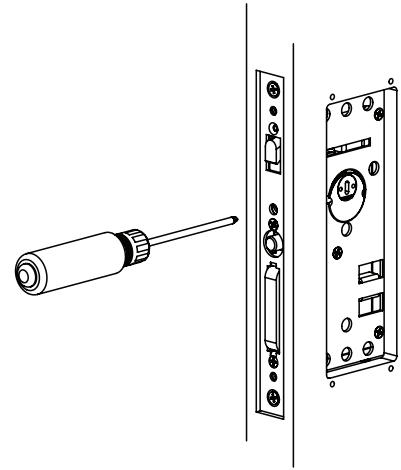

Tighten locking screw to engage notch on cylinder

4. Mount Inside/Outside Plates

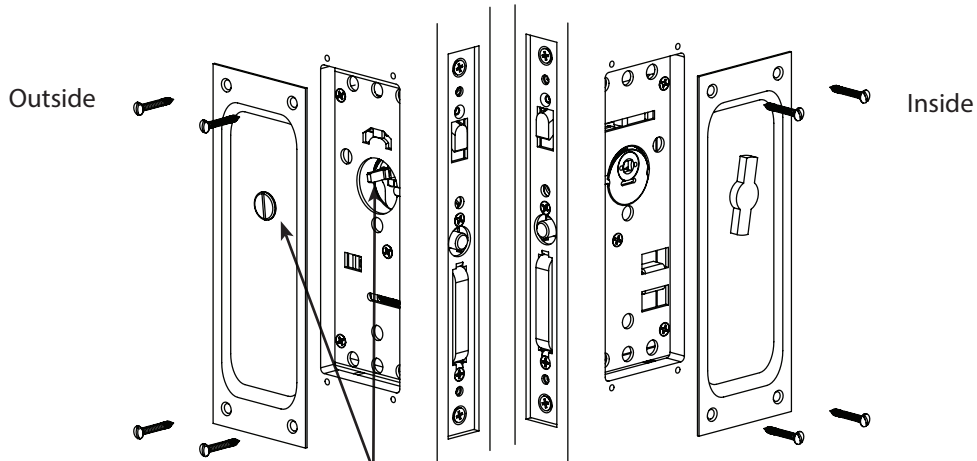

Align Passage/Privacy Button with Thumb-Turn spindle and secure trim plates to door.

5. Install Trim Plate

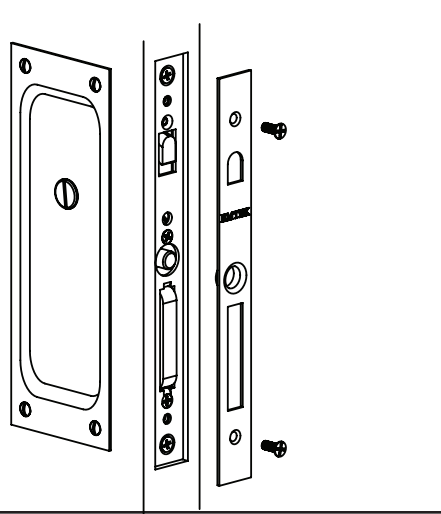

6. Install Door Jamb

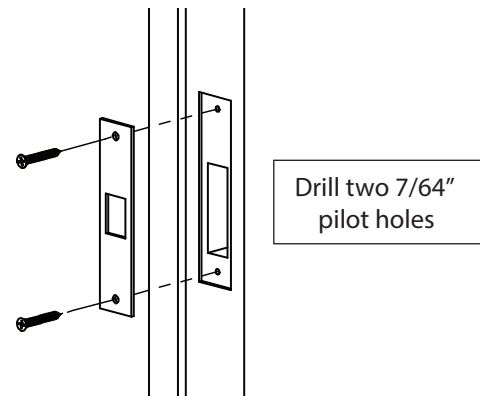

See template for door jamb prep specifications

1. Install Lock Body

2. Install Drive Bar Cylinder

3. Tighten Drive Bar Cylinder

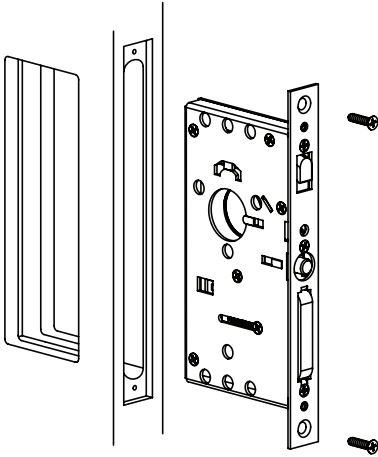

See template for door prep specifications

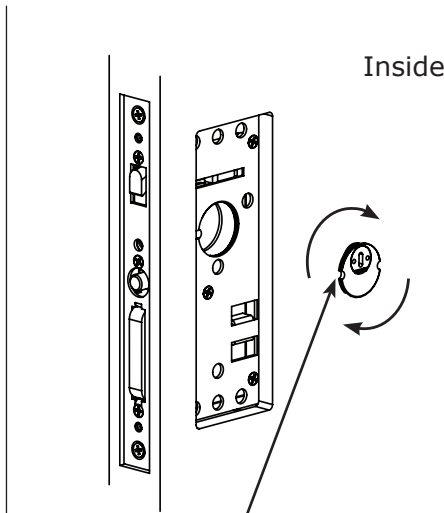

Inside

Note: Notch on cylinder must be in the 9 o'clock position when fully screwed into lock body.

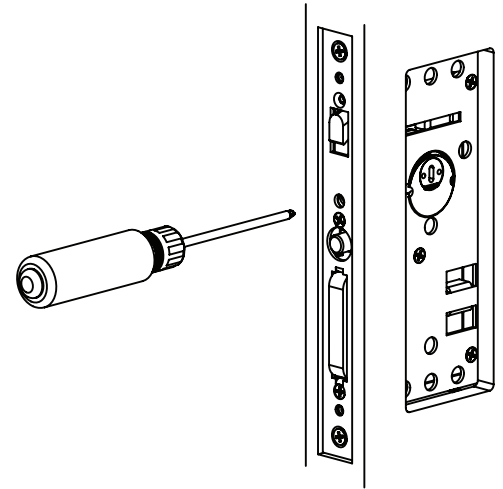

Tighten locking screw to engage notch on cylinder

4. Mount Inside/Outside Plates

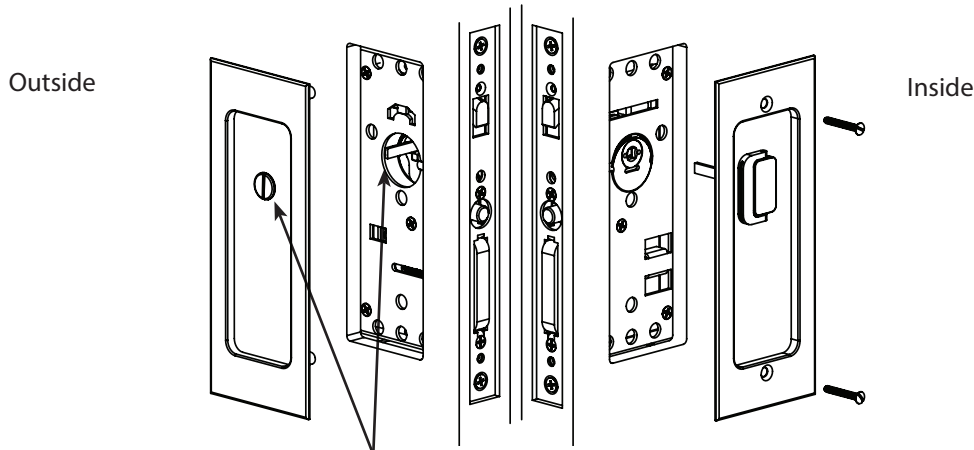

Outside

Inside

Align Passage/Privacy Button with Thumb-Turn spindle and secure trim plates to door.

5. Install Trim Plate

6. Install Door Jamb

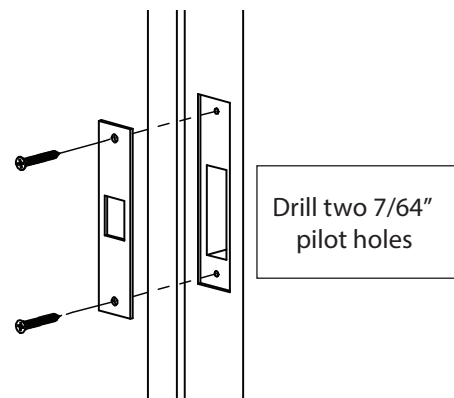
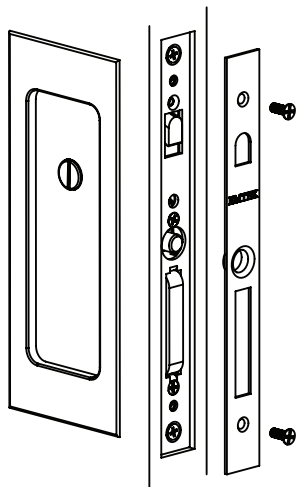

Drill two 7/64" pilot holes

See template for door jamb prep specifications