

Installation Instructions

ER2 Remote Chiller

NOTE: It is important to insure proper ventilation. Allow a minimum clearance of 6 inches (152 mm) in front and 3 inches (76mm) in the rear of the unit. If unit is to be installed in an enclosure, allow the following clearances around unit - 1 inch (25mm) each side, 3 inches (76mm) in the rear, 3 inches (76mm) inches above wall.

This chiller has been designed for use with potable water **ONLY**.

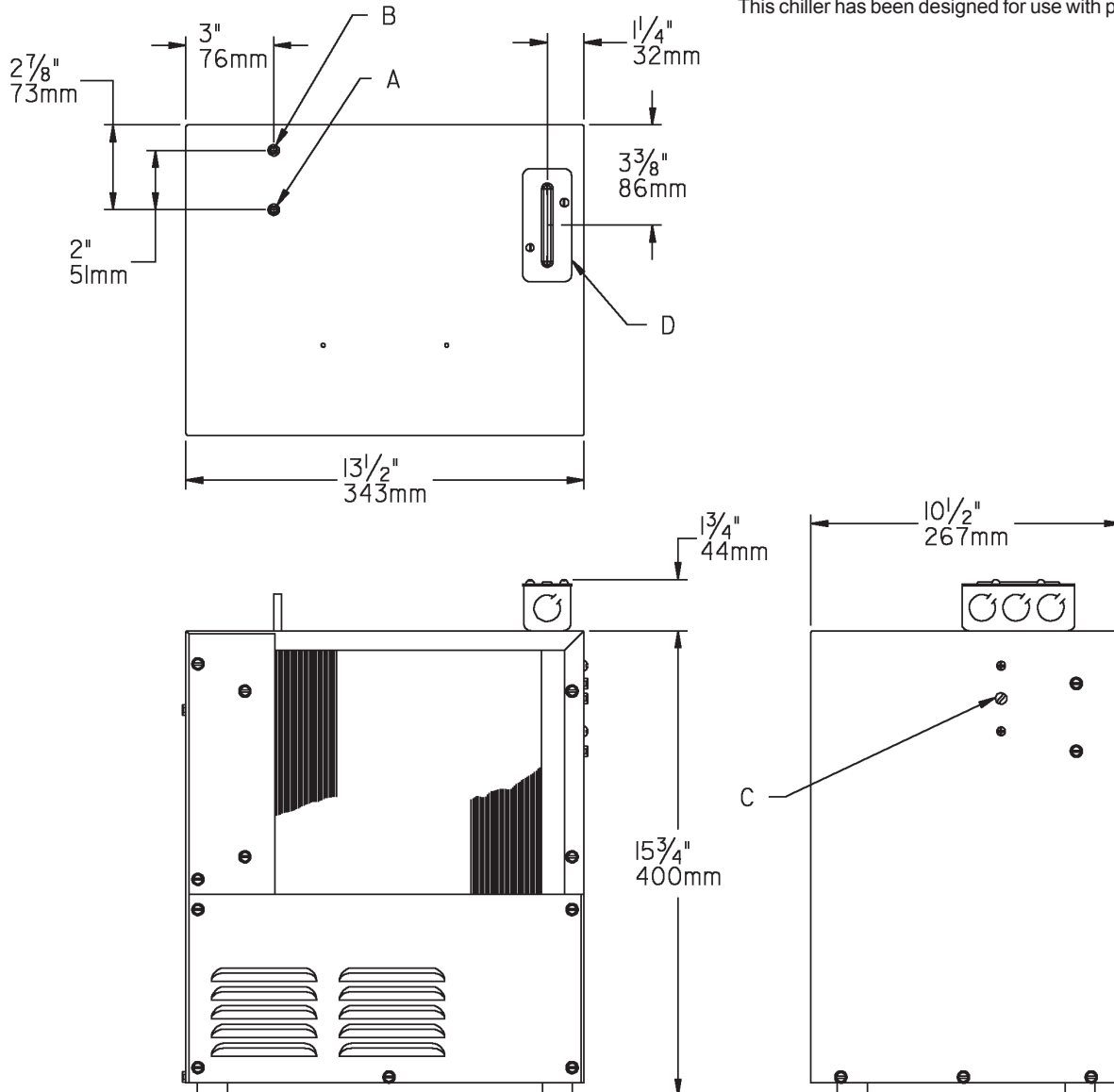

LEGEND

A = $1/4$ " (6mm) O.D. TUBE WATER OUT

B = $1/4$ " (6mm) O.D. TUBE WATER INLET

C = TEMPERATURE ADJUSTMENT

D = ELECTRICAL

ITEM NO.	PART NO.	DESCRIPTION
1	30040C	Cover - Electrical Box
2	30039C	Box - Electrical
3	98773C	Kit - Cold Control/Screws
4	31341C	Motor - Fan
5	30824C	Fan - Blade
6	42677000	Fan - Bracket
7	111543043890	Nut - Hex #6-32
8	66266C	Condenser
*9	0000001194	Compressor Service Pak
10	98747C	Kit - Electrical (Relay/Cvr/O/L)
11	98181C	Kit - Heat Exchanger/Drier
12	98777C	Kit - Compr. Mounting Hardware
13	66201C	Drier
14	66810C	Evaporator Assy
15	50930C	Bumper
16	23105C	Cabinet
17	27304C	Baseplate
18	23107C	Panel - Rear (Not Shown)
19	23108C	Panel - Front
20	23109C	Panel - Condenser Mounting
NS	56092C	Poly Tubing (Cut To Length)
NS	75583C	Elbow - 5/16" x 1/4"

220/240V 50HZ

ITEM NO.	PART NO.	DESCRIPTION
4	31395C	Motor - Fan
*9	35967C	Compr. Service Pak
10	98746C	Kit - Electrical (Relay/Cvr/O/L)
11	0000001014	Kit - Heat Exchanger/Drier
13	66200C	Drier

***INCLUDES RELAY & OVERLOAD. IF UNDER WARRANTY, REPLACE WITH SAME COMPRESSOR USED IN ORIGINAL ASSEMBLY.**

NOTE: All correspondence pertaining to any of the above water cooler or orders for repair MUST include model number and serial number of cooler, name and part number of replacement part.

115V/220V WIRING DIAGRAM

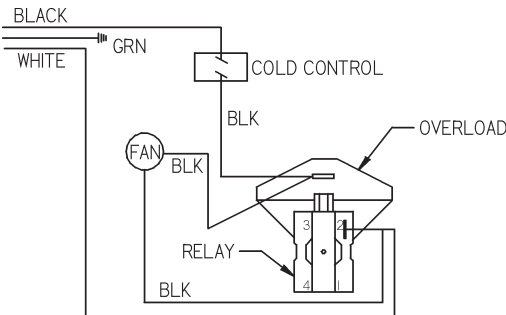

INSTALLATION

1. It is important to insure proper ventilation. For remote installation a minimum clearance of 6 inches (152 mm) to the front must be maintained, 1 inch (25 mm) each side, 3 inches (76 mm) to the rear above the unit. Wall grille EG-1 or EG-2 to be used when unit is inserted into an enclosure. Install unit as close as possible to wall grille. A 6 inch (152 mm) clearance beyond the front of the wall grille is required for adequate air circulation.
2. When unit is installed in a kitchen cabinet, two air openings with a minimum of 40 square inches each (minimum of 75% open area) must be provided in the cabinet. One opening should be in the overhang of the toe space. The other opening near the top of the cabinet. The remote unit must be installed with a minimum of 3 inch clearance between the unit and the walls of the cabinet. In addition a minimum 2 inch clearance must be provided between the toe space air opening and front of remote unit.
3. Water inlet is 1/4" (6 mm) O.D. tube. Contractor to supply connections as required.
4. Connecting lines to be of copper, thoroughly flushed to remove all foreign matter before being connected to chiller. If flushing does not remove all particles, a water strainer should be installed in supply line.
5. Connect cooler to building supply line with a shut-off valve and install a union connection between the valve and chiller.
6. Electrical: Make sure power supply is identical in voltage, cycle, and phase to that specified on chiller serial plate. Never wire compressor directly to the power supply.

START-UP

1. Open supply line valve.
2. Purge air from all water lines by operating bubbler valve of fountain to which chiller is connected. Steady stream assures all air removed.
3. Rotate fan to insure proper clearance and free fan action.
4. Connect to electrical power.

TROUBLE SHOOTING & MAINTENANCE

Temperature Control: Factory set at 50°F (+/- 5°) under normal conditions. For colder water, adjust screw on item no. 3 CW.

Ventilation: Cabinet louvers and condenser fins should be periodically cleaned with brush, air hose or vacuum cleaner. Excess dirt or poor ventilation can cause no cold water and compressor cycling on the compressor overload protector.

Lubrication: Motors are lifetime lubricated.

ACTUATION OF QUICK CONNECT WATER FITTINGS:

Chiller is provided with a lead-free plug which utilizes an o-ring water seal. To remove plug from chiller, relieve water pressure, pull the collar towards the fitting and pull the fitting off the tube. To install plug, push fitting straight onto tubing until it reaches a positive stop, approximately 3/4 in. (19mm).

OPERATION OF QUICK CONNECT FITTINGS

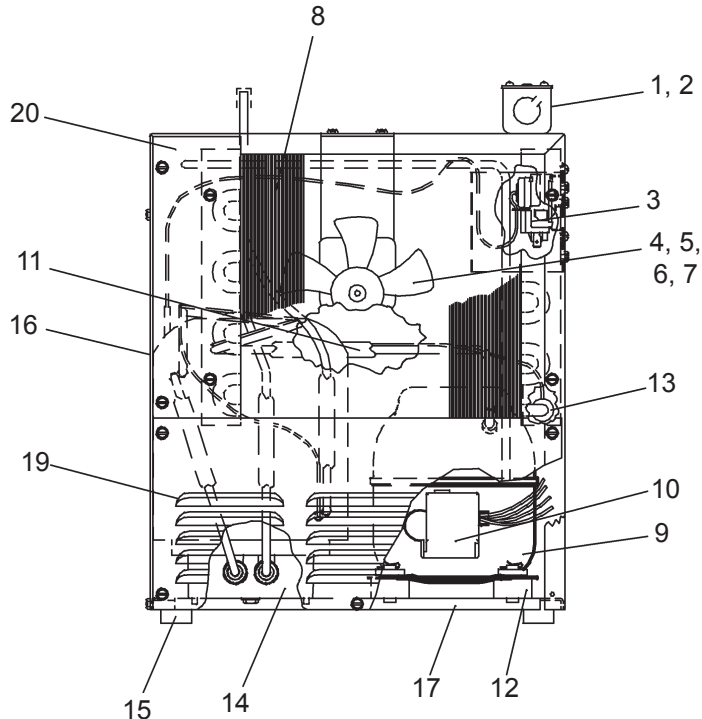
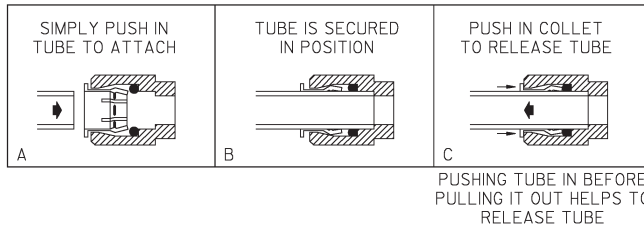

FOR PARTS, CONTACT YOUR LOCAL DISTRIBUTOR OR CALL 1.800.323.0620
REPAIR SERVICE INFORMATION TOLL FREE NUMBER 1.800.260.6640

ELKAY MANUFACTURING COMPANY • 2222 CAMDEN COURT • OAK BROOK, IL 60523 • 630.574.8484