

ELKAY®

SPECIFICATIONS

No Lead Drinking Fountain Soft Sides® Wall Mount – Fully Exposed Model EDFPVR214RC

PRODUCT SPECIFICATION

Wall-mounted drinking fountain constructed of a premium composite, solid-surface material. Offer a contemporary look with smooth rounded lines. White Granite finish.

Contoured basin minimizes splashing and has exclusive one-piece, heavy duty Vandal-resistant bubbler. Easy to operate, fully functional chrome plated pushbutton is vandal-resistant. Bottom cover plate included. Flow regulator provides constant stream from 20 to 105 psi water pressure.

Complies with the requirements of A.D.A. (American's with Disabilities Act) when properly installed.

NO LEAD DESIGN

THIS DRINKING FOUNTAIN COMPLIES WITH THE LEAD-FREE DEFINITION IN THE SAFE DRINKING WATER ACT OF 1986 AND LEAD CONTAMINATION CONTROL ACT OF 1988.

Elkay Drinking Fountains are manufactured with a waterway system utilizing copper components and completely lead-free material. These waterways have no lead because all leaded materials, such as leaded brass, have been removed.

This fountain is certified by WQA to lead-free compliance including **NSF/ANSI 61 and 372.**

ACCESSORIES

MPW101 In wall carrier mounting plate

ML100 Support columns for MPW101



CONSTRUCTION

EDFPVR214RC furnished complete with vandal-resistant bubbler, heavy-duty push button and vandal-resistant bottom cover plate.

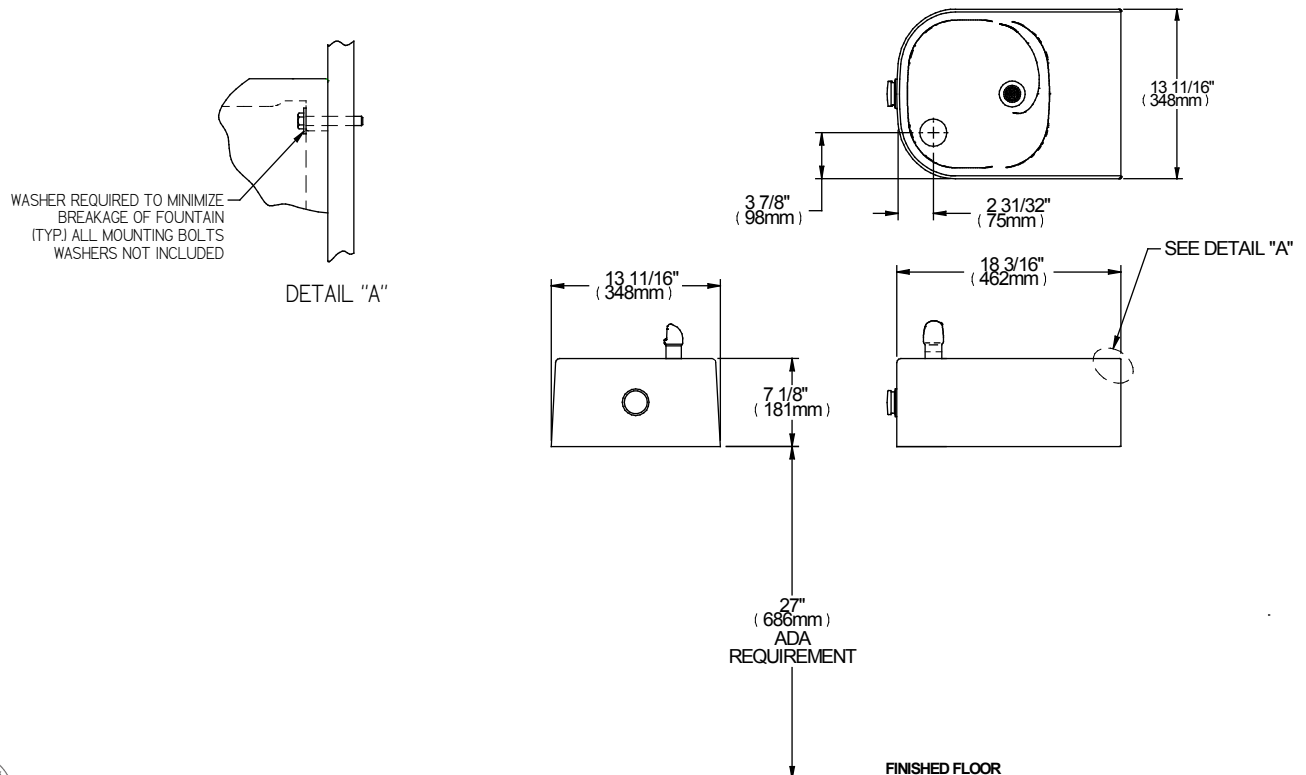

This specification describes an Elkay product with design, quality and functional benefits to the user. When making a comparison of other producer's offerings, be certain these features are not overlooked.

**No Lead Drinking Fountain Soft Sides®
Wall Mount – Fully Exposed
Model EDFPVR214RC**

**ELKAY®
ROUGH-IN DIMENSIONS**

INSTALLER NOTE

THIS DRINKING FOUNTAIN IS FURNISHED WITH A BUBBLER AND VALVE INCLUDING ALL CONNECTING FITTINGS WHICH ARE MANUFACTURED OF COMPLETELY LEAD FREE MATERIAL. SHUT OFF VALVE (NOT FURNISHED) TO ACCEPT 3/8" O.D. UNPLATED COPPER TUBE.

CARE AND MAINTENANCE OF ELKAY COMPOSITE FOUNTAINS

The premium composite fountain provides an extremely durable, nonporous surface which resists staining. Care is very simple. Routine cleaning with a soft sponge or cloth, or with water or non-abrasive aerosol foam cleaner, is all that is normally needed to give many years of trouble free service. Cleaners left standing on the fountain surface can dull the surface finish. Be certain to rinse all cleaning agents completely and polish with a soft cloth. Harsh abrasive cleaners are not required and should not be used.

Mild abrasives such as liquid automotive cleaning compound or baking soda paste will remove simple scratches and stains. Cigarette burns can normally be removed without noticeable effect. Deeper scratches or gouges can be corrected with fine grit sandpaper (240 grit then 400 grit) or a green Scotchbrite™ pad.

To maintain or regain luster and make cleaning easier, periodic applications of automobile wax or like products will keep the finish looking like new.

OPERATION OF QUICK CONNECT FITTINGS

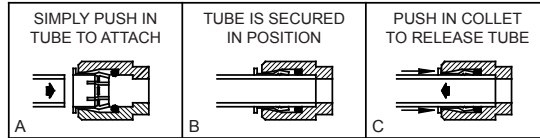

PUSHING TUBE IN BEFORE PULLING IT OUT HELPS TO RELEASE TUBE

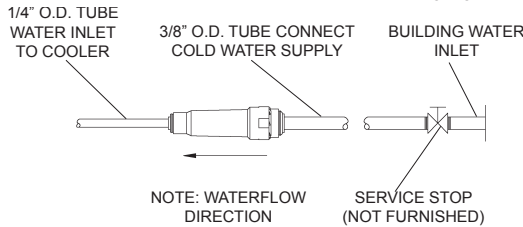

WALL ROUGH-IN

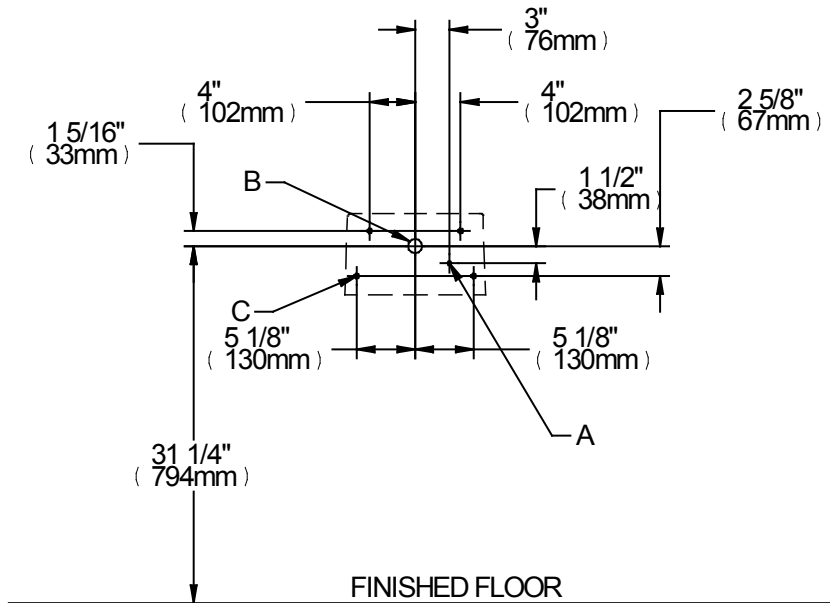

Job Name: _____
 Model: _____ Qty. _____
 Contact: _____
 Approval Signature: _____
 Notes: _____

LEGEND:

- A = Recommended water supply location 3/8" O.D. unplated copper tube connect
- B = Recommended location for waste outlet 1-1/4" O.D. drain
- C = Mounting holes for securing fountain to wall.