

PRODUCT SPECIFICATIONS

Elkay Outdoor ezH2O® Bottle Filling Station Wall Mount, Bi-Level Non-Filtered Non-Refrigerated. Features shall include 316 Stainless, Laminar Flow, Heavy Duty Vandal-Resistant. Furnished with Vandal-Resistant bubbler. Mechanical Bottle Filler Button With Mechanical Front Bubbler Button activation. Product shall be Wall Mount (On-Wall), for Outdoor applications, serving 3 station(s). Unit shall be lead-free design which is certified to NSF/ANSI 61 & 372 (lead free) and meets Federal and State low-lead requirements.

Special Features:	316 Stainless, Laminar Flow, Heavy Duty Vandal-Resistant
Finish:	Beige (BGE), Black (BLK), Blue (BLU), Brown (BRN), Evergreen (EVG), Gray (GRY), Orange (ORN), Powder Coat (12 Color Options), Purple (PUR), Red (RED), Terracotta (TER), White (WHT), Yellow (YLW)
Power:	No Electrical Required
Bubbler Style:	Vandal-Resistant
Activation by:	Mechanical Bottle Filler Button With Mechanical Front Bubbler Button
Mounting Type:	Wall Mount (On-Wall)
Chilling Option:	Non-Refrigerated
Dimensions (L x W x H):	21-1/4" x 32-7/8" x 38-7/16"
Approx. Shipping Weight:	203 lbs.
Installation Location:	Outdoor
No. of Stations Served:	3

- Mechanically-Activated bubbler continues to supply water in event of service disruptions.
- Laminar flow provides clean fill with minimal splash.
- Base material constructed from marine-grade 316 stainless steel provides the ultimate corrosion protection from even the most corrosive elements.
- Heavy Duty Vandal-Resistant:
 - Tamper resistant screws
 - Resists stains and corrosion
 - Heavy-gauge construction
- Vandal-resistant, bubblers are one-piece, chrome plated with integral hood guard design to prevent contamination from other users, airborne deposits and tampering.



AMERICAN PRIDE. A LIFETIME TRADITION.
Like your family, the Elkay family has values and traditions that endure. For almost a century, Elkay has been a family-owned and operated company, providing thousands of jobs that support our families and communities.



PRODUCT COMPLIANCE

ADA & ICC A117.1
Buy American Act
NSF/ANSI 61 & 372 (lead free)



[Clean and Care Manual \(PDF\)](#)
[Installation Instructions \(PDF\)](#)

Warranty pertains to drinking water applications only. Non-drinking water applications are not covered under warranty.

[Warranty \(PDF\)](#)

PART: _____ QTY: _____
PROJECT: _____
CONTACT: _____
DATE: _____
NOTES: _____
APPROVAL: _____

In keeping with our policy of continuing product improvement, Elkay reserves the right to change product specifications without notice. Please visit elkay.com for the most current version of Elkay product specification sheets. This specification describes an Elkay product with design, quality, and functional benefits to the user. When making a comparison of other producers' offerings, be certain these features are not overlooked.

MOUNTING INSTRUCTIONS and PLUMBING CONNECTIONS

Refer to diagrams for plumbing rough-in. This fountain is to be mounted on a smooth, flat finished wall surface with adequate support.

Note: Wall mounting structure must be capable of supporting 300lb. load minimum on fountain. To secure unit, use 3/8 minimum fasteners (not provided). Water service line and waste line are to be assembled as required. Final check for leaks and correct functions of fountain should be made. (For details see the installation instructions.)

Installation requires trap to be installed in wall. A service supply stop must be installed at the fountain inlet line. Trap and service stop not included.

Caution - Fountain must be securely bolted to wall.

Note: For wall support required locations see installation instructions provided with fountain.

OPERATING PRESSURES:
Supply water 20 - 105 psi maximum

TOP VIEW

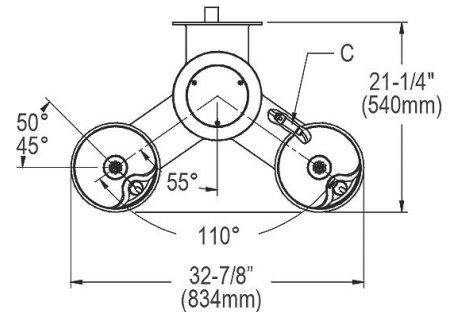

OPERATION OF QUICK CONNECT FITTINGS

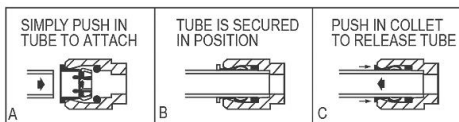

PUSHING TUBE IN BEFORE PULLING IT OUT HELPS TO RELEASE TUBE

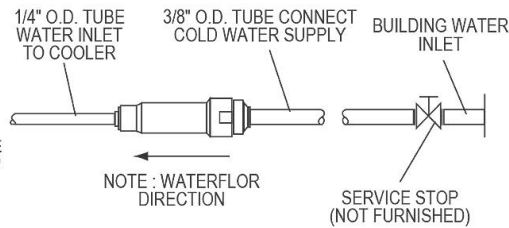

BACK VIEW

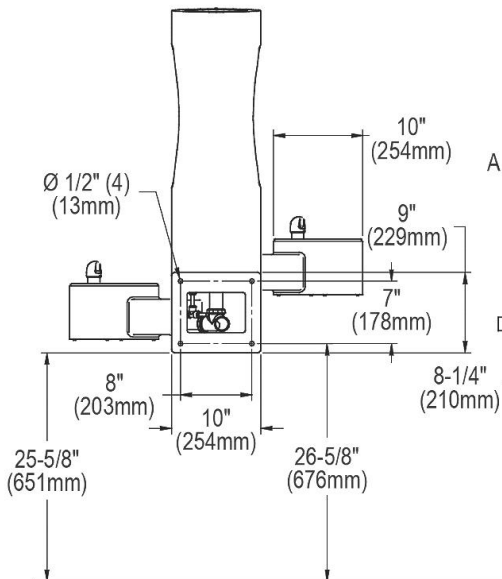

SIDE & FRONT VIEWS

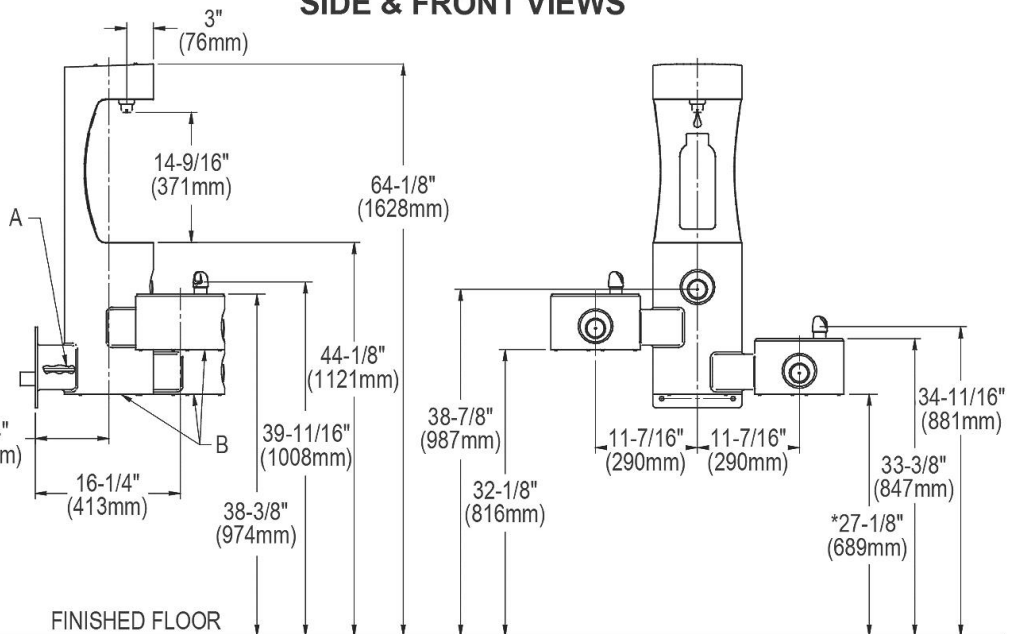

* ADA Requirement

A = 3/8" O.D. UNPLATED COPPER TUBE CONNECT - SHUT OFF VALVE BY OTHERS
B = REMOVABLE BOTTOM COVER
C = IN-LINE STRAINER

In keeping with our policy of continuing product improvement, Elkay reserves the right to change product specifications without notice. Please visit elkay.com for the most current version of Elkay product specification sheets. This specification describes an Elkay product with design, quality, and functional benefits to the user. When making a comparison of other producers' offerings, be certain these features are not overlooked.