

PRODUCT SPECIFICATIONS

Elkay Outdoor EZH2O[®] Bottle Filling Station, Bi-Level Pedestal with Pet Station Non-Filtered, Non-Refrigerated Freeze Resistant. Features shall include E-Coat, Freeze Resistant, Heavy Duty Vandal-Resistant, Laminar Flow, Pet Fountain. Furnished with Vandal-Resistant bubbler. Mechanical Front Bubbler Button activation. Product shall be Floor Mount/Freestanding, for Outdoor applications, serving 2 station(s). Unit shall be lead-free design which is certified to NSF/ANSI 61 & 372 (lead free) and meets Federal and State low-lead requirements.

Special Features:	E-Coat, Freeze Resistant, Heavy Duty Vandal-Resistant, Laminar Flow, Pet Fountain
Finish:	Beige (BGE), Black (BLK), Blue (BLU), Brown (BRN), Evergreen (EVG), Gray (GRY), Orange (ORN), Purple (PUR), Red (RED), Terracotta (TER), White (WHT), Yellow (YLW)
Power:	No Electrical Required
Bubbler Style:	Vandal-Resistant
Activation by:	Mechanical Front Bubbler Button
Mounting Type:	Floor Mount/Freestanding
Chilling Option:	Non-Refrigerated
Full Load Amps	0
Dimensions (L x W x H):	26" x 31" x 64"
Approx. Shipping Weight:	224 lbs.
Installation Location:	Outdoor
No. of Stations Served:	2

Special Note: Bottle Filler Stations 1 (Low), Bubbler Stations 1 (Upper), Choose from 12 color options



AMERICAN PRIDE. A LIFETIME TRADITION. Like your family, the Elkay family has values and traditions that endure. For almost a century, Elkay has been a family-owned and operated company, providing thousands of jobs that support our families and communities.



Included with Product: Outdoor Bottle Filler, Freeze Resistant Valve

PRODUCT COMPLIANCE

ADA
Buy American Act
GreenSpec[®]
NSF/ANSI 61 & 372 (lead free)



[Installation Instructions \(PDF\)](#)

Warranty pertains to drinking water applications only. Non-drinking water applications are not covered under warranty.

[Warranty \(PDF\)](#)

OPTIONAL ACCESSORIES

LK4471LHB - Locking Hose Bib
97890C - Accessory - Direct Bury Adaptor
LK4470NLHB - Hose Bib

PART: _____ QTY: _____

PROJECT: _____

CONTACT: _____

DATE: _____

NOTES: _____

APPROVAL: _____

In keeping with our policy of continuing product improvement, Elkay reserves the right to change product specifications without notice. Please visit elkay.com for the most current version of Elkay product specification sheets. This specification describes an Elkay product with design, quality, and functional benefits to the user. When making a comparison of other producers' offerings, be certain these features are not overlooked.

- Mechanically-Activated bubbler continues to supply water in event of service disruptions.
- Laminar flow provides clean fill with minimal splash.
- Heavy Duty Vandal-Resistant:
 - Tamper resistant screws
 - Resists stains and corrosion
 - Heavy-gauge construction
- Vandal-resistant, bubblers are one-piece, chrome plated with integral hood guard design to prevent contamination from other users, airborne deposits and tampering.
- Unique E-Coat immersion process coats the inside and outside of the fountain for ultimate corrosion protection.
- Pet Fountain: Features slow drainage for easy drinking.
- Freeze Resistant:
 - Depending on specific installation, freeze resistant system is located either below frost line or in temperature controlled space.

In keeping with our policy of continuing product improvement, Elkay reserves the right to change product specifications without notice. Please visit elkay.com for the most current version of Elkay product specification sheets. This specification describes an Elkay product with design, quality, and functional benefits to the user. When making a comparison of other producers' offerings, be certain these features are not overlooked.

MOUNTING INSTRUCTIONS and PLUMBING INSTRUCTIONS

Site and drainage excavation is required for fountain installation. Refer to owner's manual for site preparation details. Provide solid, well-drained surface to mount pedestal fountain (concrete pad recommended) with adequate support (300 lb. load minimum). (8) 3/8" minimum fasteners (not included) should be attached securely to mounting surface in order to secure fountain, (Refer to rough-in diagram), and be sure to allow an opening for the freeze-resistant valve in the ground as shown in the installation instructions that accompany the fountain. (Refer to page 4 for freeze resistant valve installation). NOTE: Pet Fountain will not be freeze resistant. Refer to local codes for any additional requirements. Locate and install plumbing through ground as required. Assemble fountain to prepared site and mounting pad.

NOTE: Fountain is not furnished with service valve. Position pedestal over plumbing and secure base to fasteners. Remove access panels and connect supply and water lines. Turn on water supply and check for leaks. Refer to owner's manual for detailed instructions. Reassemble access panels to pedestal.

Trap and service stop not included.

OPERATING PRESSURES:

Supply water 20 – 105 psi maximum

TOP VIEW

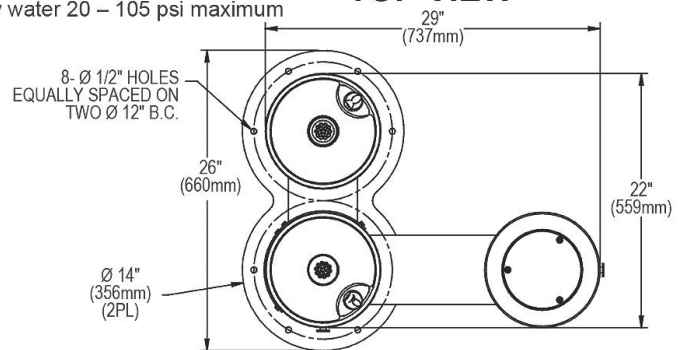

FRONT & SIDE VIEWS

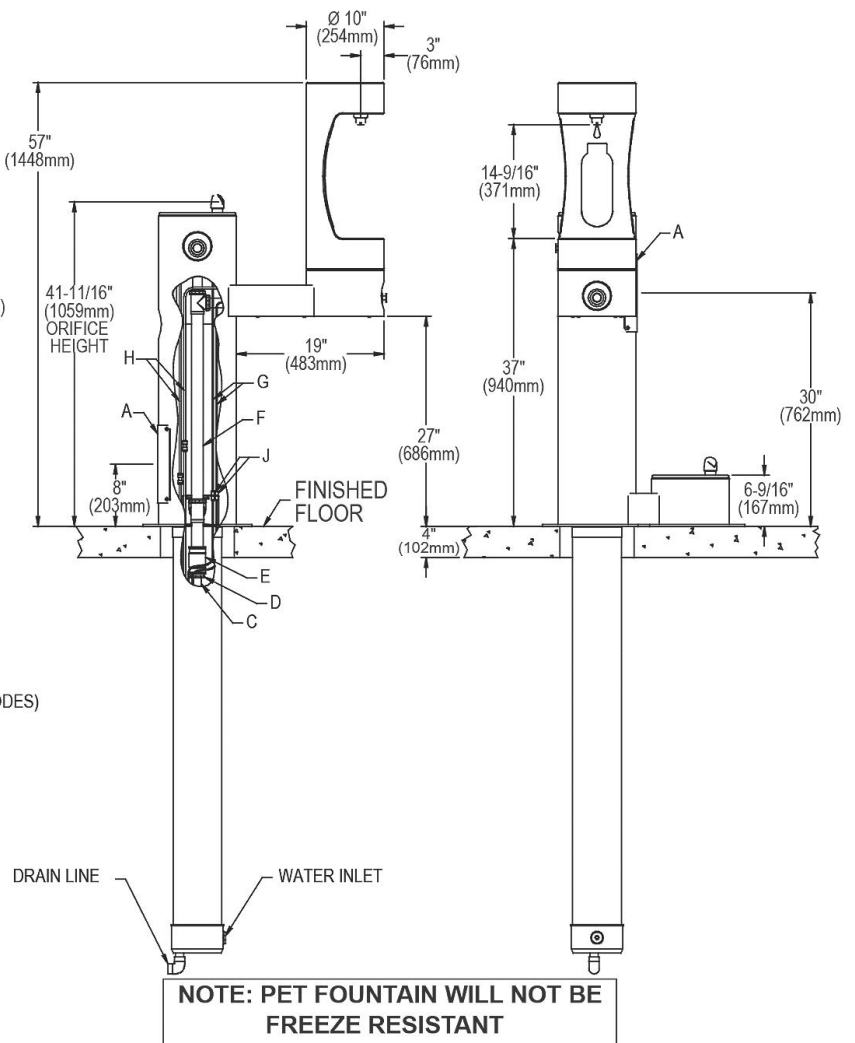

SITE PREPARATION DETAIL

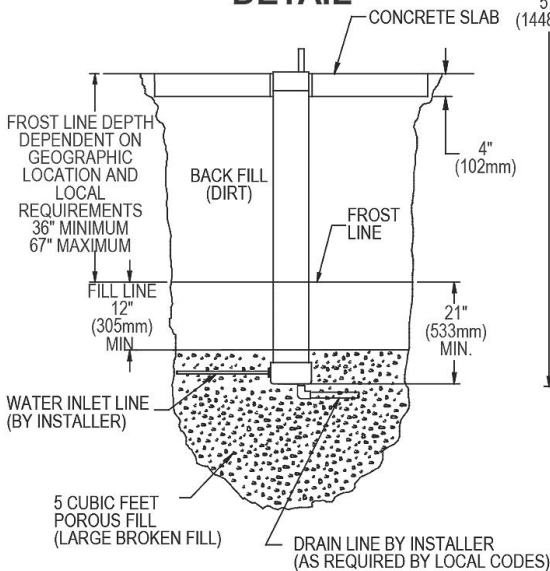

LEGEND

- A = ACCESS PANEL (8" X 10")
- B = REMOVABLE BOTTOM COVER
- C = 1" PVC DRAIN
- D = PRESSURE FITTING 1-1/4" x 3/4"
- E = CONNECTOR 1-1/4" to 1-1/4"
- F = 1-1/4" DRAIN TUBE
- G = AIR CONTROL LINE
- H = 1/4" WATER LINE
- J = CONNECTOR FOR AIR CONTROL LINE

In keeping with our policy of continuing product improvement, Elkay reserves the right to change product specifications without notice. Please visit elkay.com for the most current version of Elkay product specification sheets. This specification describes an Elkay product with design, quality, and functional benefits to the user. When making a comparison of other producers' offerings, be certain these features are not overlooked.