

PRODUCT SPECIFICATIONS

Elkay Water Dispenser 4 GPH Hot Filtered Stainless Steel. Features shall include Chilled Water, Energy Savings, Filtered, Hot Water, Sparkling Water, UV Light. Product shall be Countertop mounted/Freestanding.

Special Features:	Chilled Water, Energy Savings, Filtered, Hot Water, Sparkling Water, UV Light
Model Type:	Countertop
Material:	Stainless Steel
Dimensions (L x W x H):	19-1/4" x 13" x 18-3/8"
Approx. Shipping Weight:	88 lbs.
Cooling Capacity:	4.0 GPH (85.6 oz. cups/hour)
Refrigerant Gas:	R134a
Condensation Control:	Forced ventilation (fan)
Hot Water Temperature:	185° F
Hot Water Tank Capacity:	0.265 gallons
Heater Rating:	1000 W
Inlet Water Line:	3/8, PE plastic tubing
Electrical:	115V/60Hz
Power Consumption:	1350 W
Working Room Temperature:	Min 41° F – Max 107° F
Filter Capacity:	6000 gallons or 6 months
*Based on 68° F inlet water & 77° F ambient air temp for 50° F chilled drinking water.	

- Filter is certified to NSF 42 for particulate, chlorine, taste, and odor reduction.
- UV Light prohibits bacterial growth on dispense nozzle.
- Energy-Savings mode reduces energy consumption by up to 75%.
- Includes hot water safety latch.
- CO₂ and H₂O display alarms.
- Internal ice bank and adjustable thermostat.
- Drip tray: no drain line required.
- Fast fill rate 1 GPM.

INSTALLATION KIT

- Installation and Operating instructions
- CO₂ Regulator
- Water Pressure Regulator
- Elkay WaterSentry® Filter and Mounting Bracket
- Additional tubing for connection to water and CO₂
- Requires fittings for connection to water supply

PART: _____ QTY: _____

PROJECT: _____

CONTACT: _____

DATE: _____

NOTES: _____

APPROVAL: _____



AMERICAN PRIDE. A LIFETIME TRADITION. Like your family, the Elkay family has values and traditions that endure. For almost a century, Elkay has been a family-owned and operated company, providing thousands of jobs that support our families and communities.

Included with Product: Installation Kit

PRODUCT COMPLIANCE

CAN/CSA C22.2 No. 120

GreenSpec®

NSF/ANSI 42, 61, & 372 (lead free)

UL 399



[Installation Instructions \(PDF\)](#)

[Warranty \(PDF\)](#)

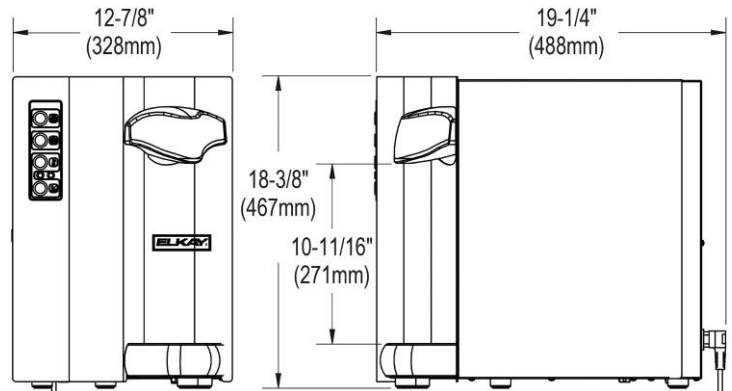

OPTIONAL ACCESSORIES

WSF6000R-2PK - WaterSentry Fresh 6000 CTO Replacement Filter (2pack)

DSCABWH - Elkay Water Dispenser Cabinet

In keeping with our policy of continuing product improvement, Elkay reserves the right to change product specifications without notice. Please visit elkay.com for the most current version of Elkay product specification sheets. This specification describes an Elkay product with design, quality, and functional benefits to the user. When making a comparison of other producers' offerings, be certain these features are not overlooked.